

01 UPPER (SHOWN)
02 LOWER (MIRROR)

NOTES:

1. WELDERS MUST BE CERTIFIED TO SECTION IX OF ASME CODE.
2. WELD PROCEDURES MUST BE IN ACCORDANCE WITH SECTION IX.
3. REFERENCE PERMEABILITY:
 BASE MATERIAL 1.05
 FABRICATED PART 1.2
 WELD 1.7
4. VISUAL WELD INSPECTION SHALL BE PERFORMED IN ACCORDANCE WITH ACCEPTANCE CRITERIA OF ASME B31.3 CATEGORY "D".

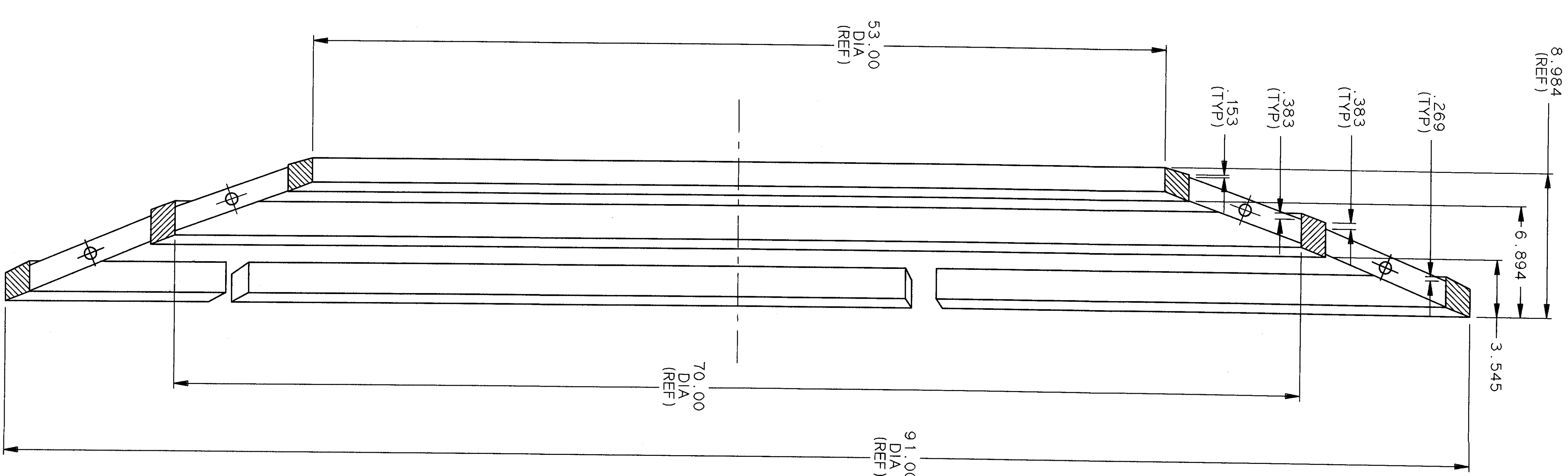

NO.	REVISION	BY	CHK	SUP	APPROVED	DATE
1						
2						
3						
4						
5						
6						
7						
8						
9						
10						
11						
12						
13						
14						
15						

COMPUTER GENERATED
 MANAGER'S SIGNATURE
 PERSONAL DESIGNER
 DATE: 3/1/98
 DRAWING NO. EDB1014
 SHEET 1 OF 1