

# Design Option #1

- Angled plates

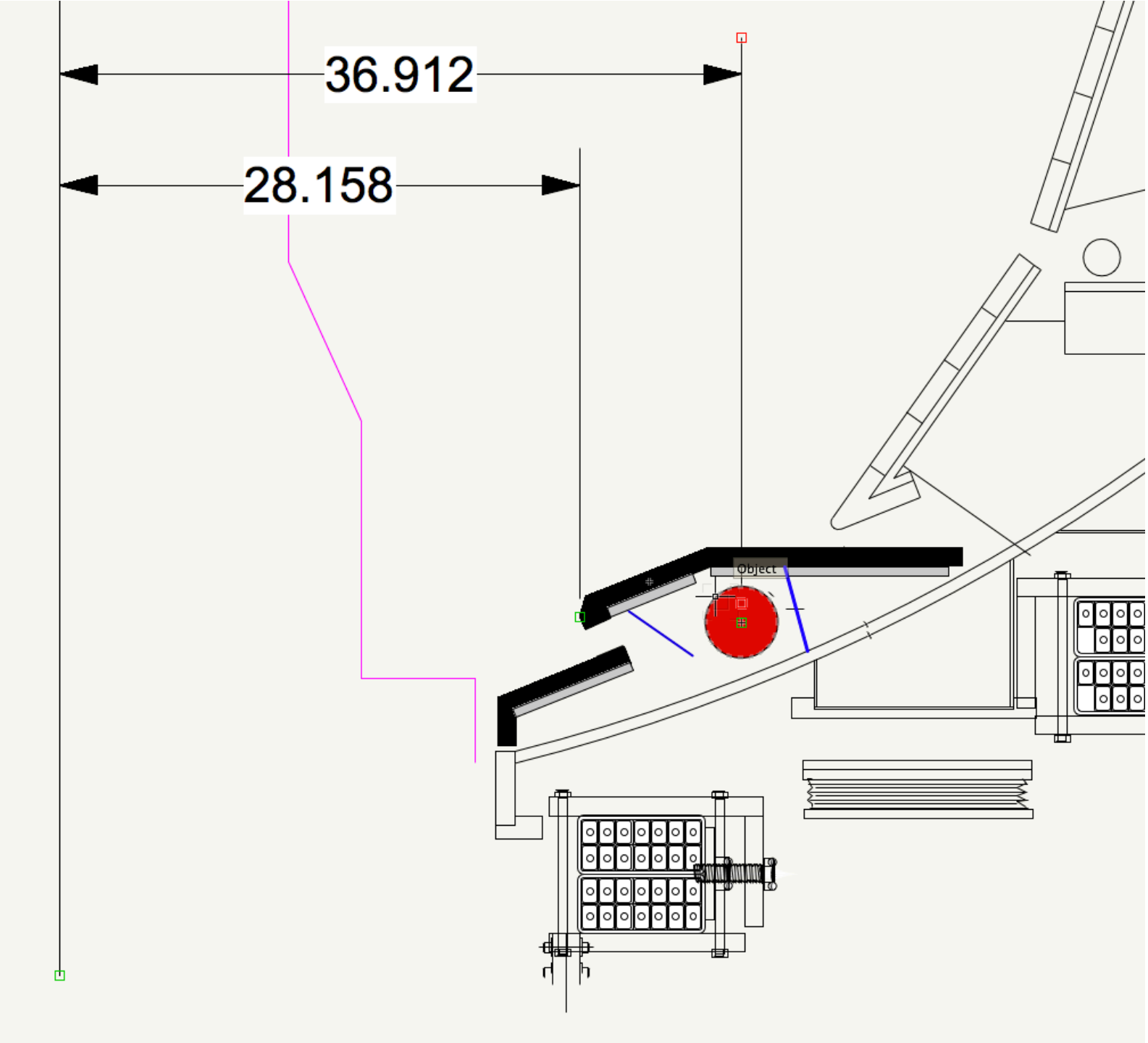

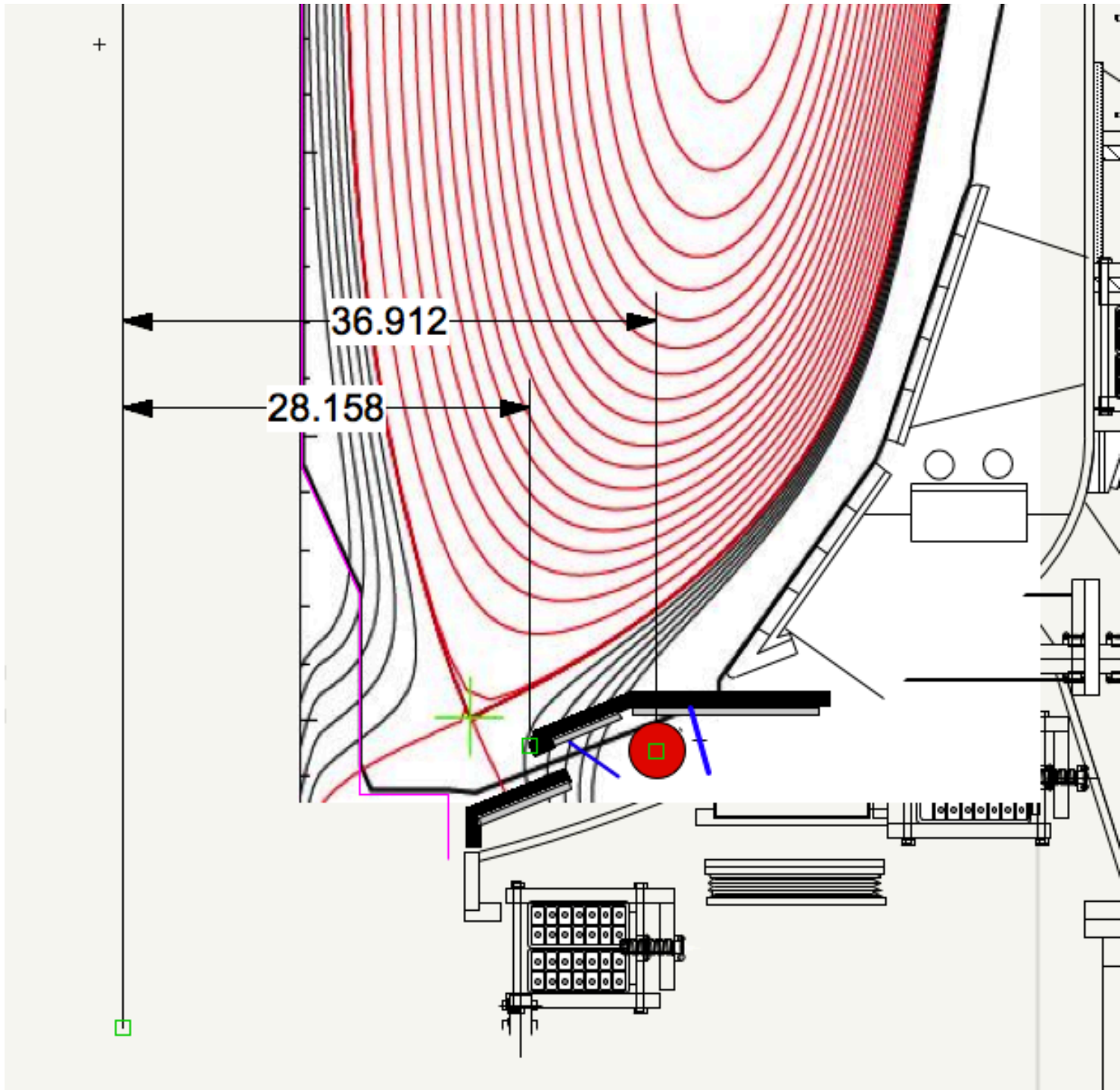

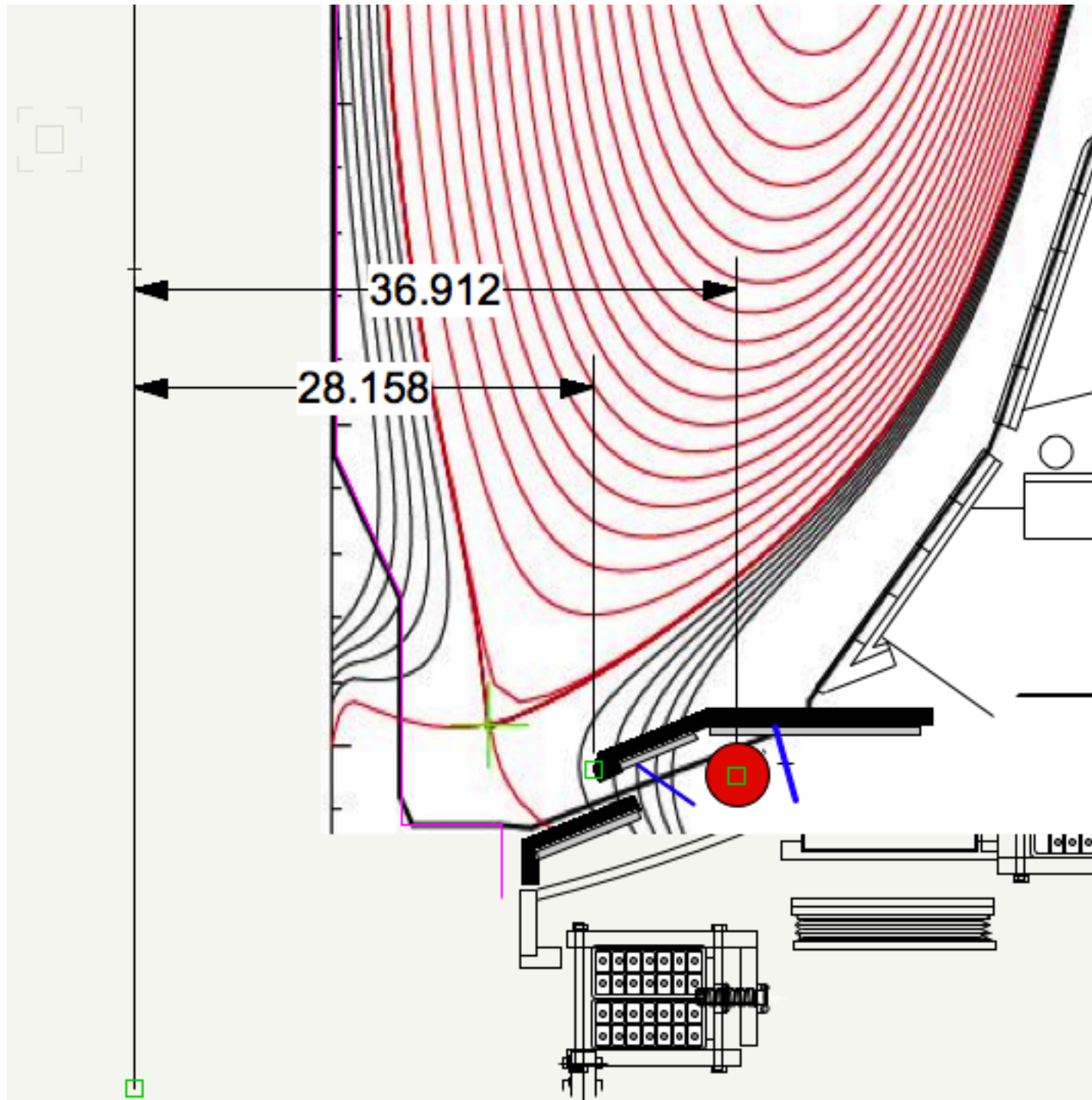

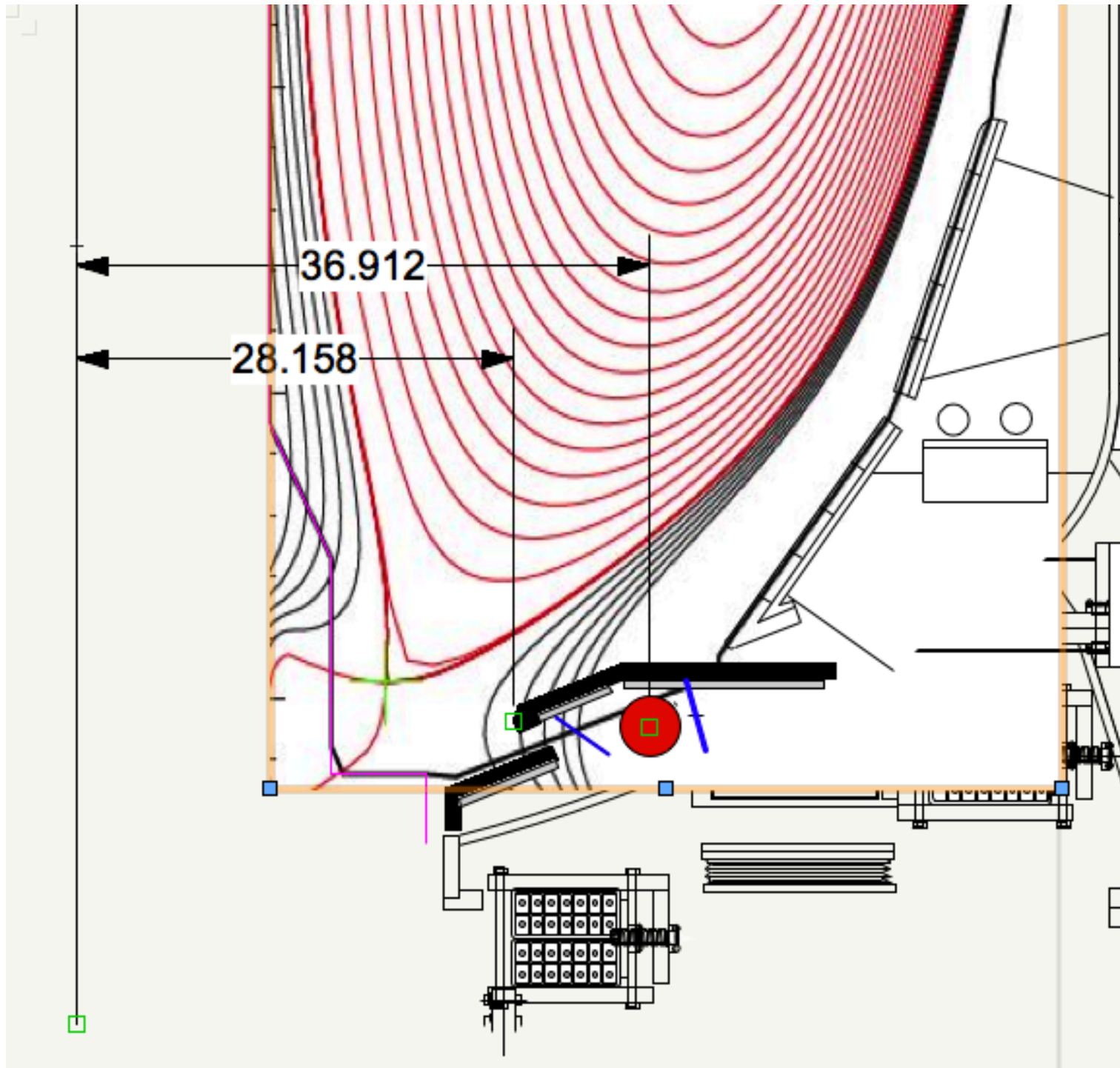

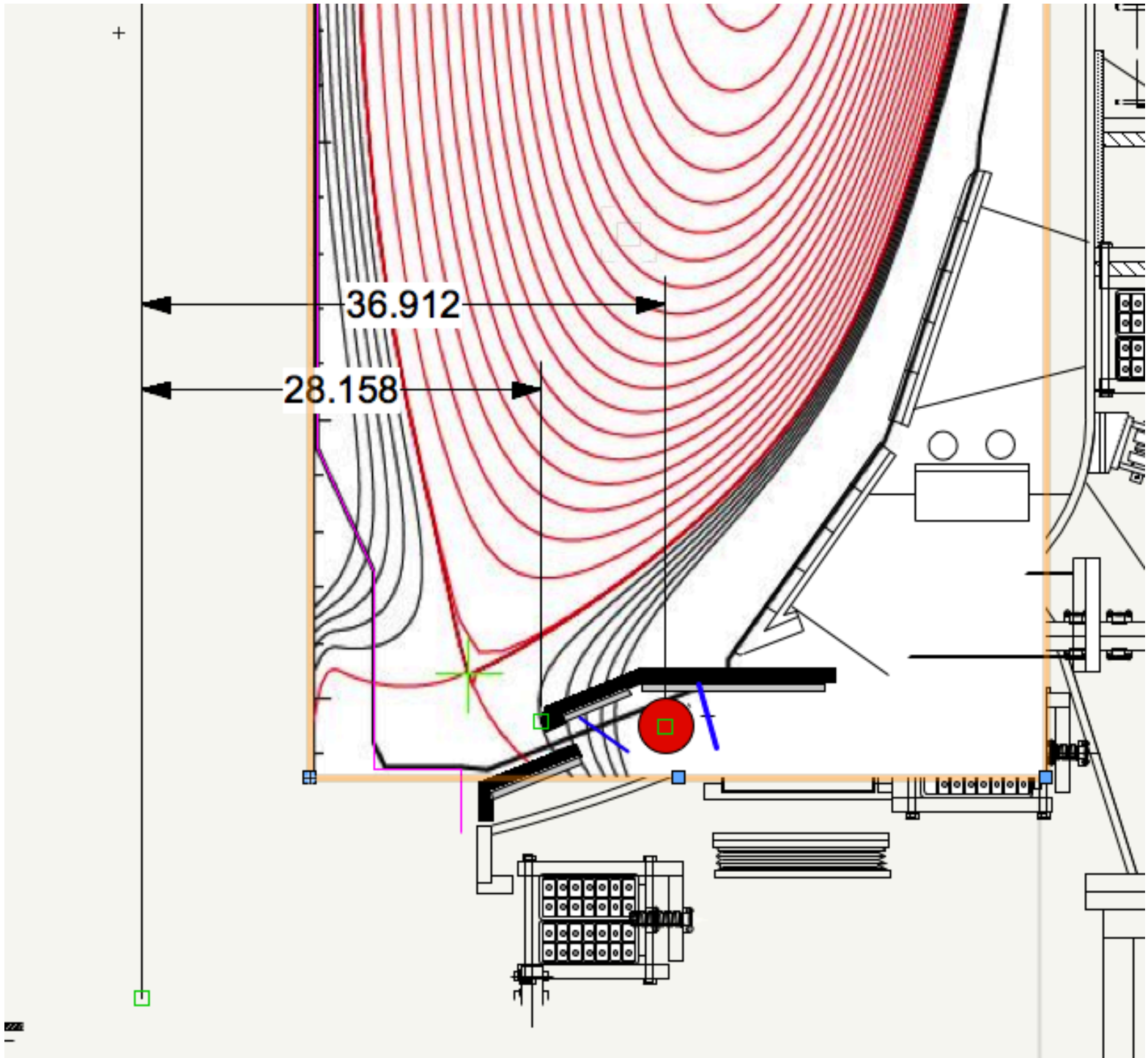

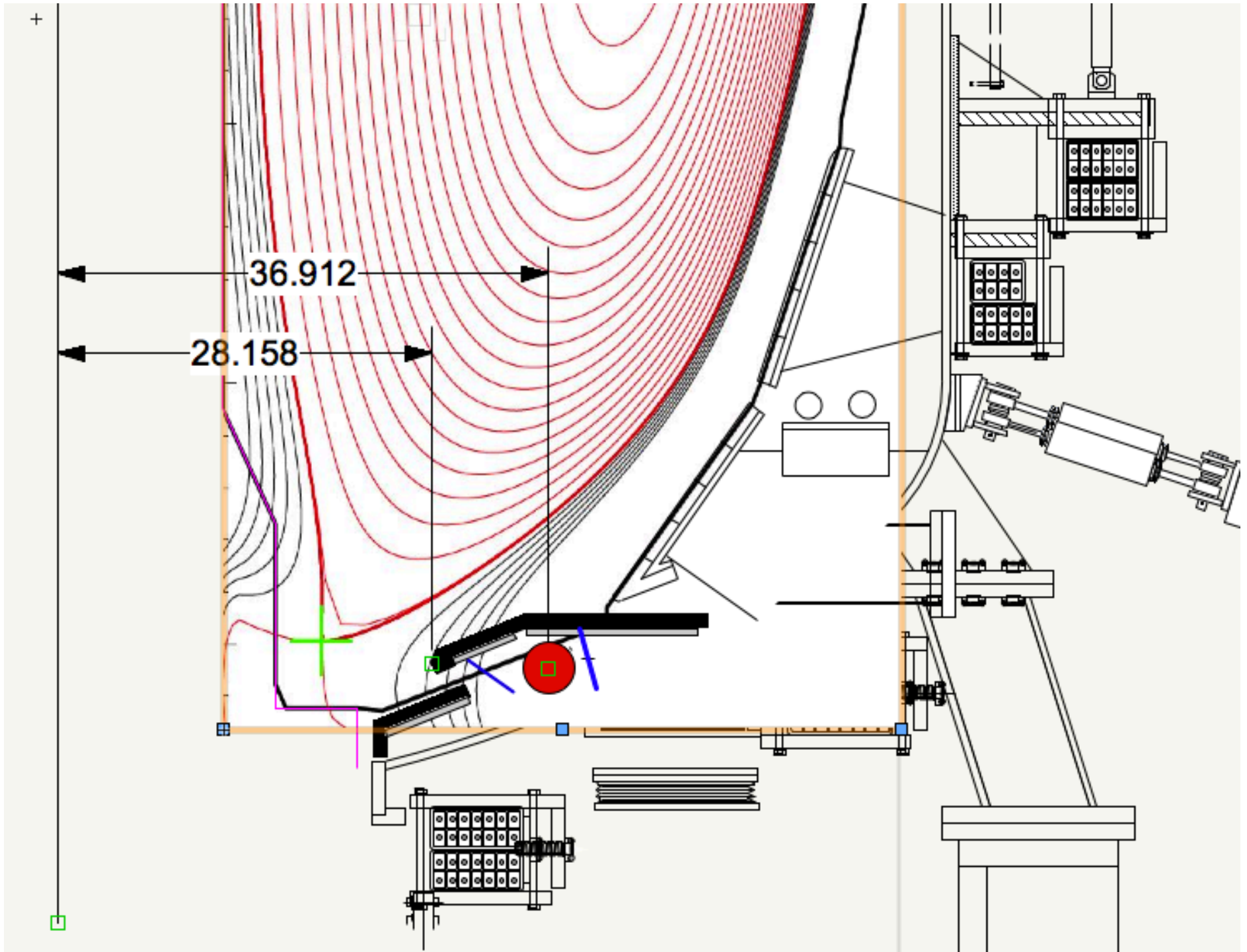

## Design Option #2

- Horizontal target outboard of the pump entrance.
- Steep ramp on the “shelf”.
- More clearance to a variety of plasma shapes.



