

High Pressure Supersonic Gas Jet Fueling on NSTX

V. A. Soukhanovskii^a, M. G. Bell^b, W. R. Blanchard^b, J. K. Dong^b, R. C. Gernhardt^b, R. Kaita^b, H. W. Kugel^b,
T. J. Provost^b, A. L. Roquemore^b, P. Sichta^b

^a *Lawrence Livermore National Laboratory, Livermore, CA, USA*

^b *Princeton Plasma Physics Laboratory, Princeton, NJ, USA*

Abstract— A supersonic gas injector (SGI) has been developed for fueling and diagnostic applications on NSTX. The SGI is comprised of a small de Laval converging-diverging graphite nozzle, a commercial piezoelectric gas valve, and a diagnostic package, all mounted on a movable probe at a low field side midplane port location. The nozzle operated in a pulsed regime at room temperature, reservoir deuterium pressure up to 2500 Torr (50 PSIA), flow rate up to 65 Torr l/s (4.55e21 particles/s), and a measured Mach number of about 4. In initial experiments the SGI was used for fueling of ohmic and 2 - 6 MW NBI-heated L- and H-mode plasmas. Reliable H-mode access was obtained with SGI fueling, with a fueling efficiency in the range 0.1 - 0.3. Good progress was also made toward a controlled density SGI-fueled H-mode plasma scenario with the flow rate of the uncontrolled high field side (HFS) gas injector reduced by up to 20. These experiments motivated a number of SGI upgrades: 1) the maximum plenum pressure has been increased to 5000 Torr (100 PSIA), 2) the plenum pressure volume has been doubled, 3) the gas delivery system has been changed to allow for injection of various gases, 4) a multi-pulse capability has been implemented. As a result of the upgrades, the maximum flow rate increased to about 130 Torr l/s. Laboratory gas jet characterization tests indicated a Mach number of about 4 with H₂ and D₂, and 4-6 with He and N₂. Plasma experiments demonstrated the high-pressure gas jet fueling compatibility with H-mode plasmas, high fueling efficiency (0.1 - 0.3), and high SOL penetration.

I. INTRODUCTION

A supersonic gas injector (SGI) has been developed on the National Spherical Torus Experiment (NSTX) [1]–[3]. Research with SGI is aimed at 1) optimization of fueling in long-pulse high-performance H-mode plasmas, and H-mode pedestal fueling studies, 2) studies of the fueling efficiency and penetration of a high-pressure supersonic gas jet in a divertor configuration, 3) studies of the synergy of efficient fueling and wall pumping provided by lithium coatings, the latter being a major Boundary Physics research thrust on NSTX [4], [5]. The SGI is comprised of a small graphite nozzle attached to a commercial piezoelectric gas valve, and a diagnostic package, all mounted on a movable probe at a low field side (LFS) midplane port location [3]. The nozzle operates in a pulsed regime at room temperature, reservoir deuterium pressure up to 2500 Torr (50 PSI) [1], [2]. In initial experiments, deuterium flow rates of up to 65 Torr l/s ($4.55 \times 10^{21} \text{ s}^{-1}$), similar to conventional NSTX gas injectors, have been used.

The SGI has been used for fueling of ohmic and 2 - 6 MW NBI-heated L- and H-mode plasmas in NSTX. Plasma fueling in NSTX is accomplished by injecting D₂ or He through piezoelectric and pneumatic valves mounted at various poloidal and toroidal locations, at the low and high field sides (HFS) of the

vacuum vessel. Conventional (sub-sonic) gas injection has low fueling efficiency, typically between 0.01 and 0.15 [6]. The fueling efficiency is defined as $\eta = (dN_i/dt) \Gamma_{gas}^{-1}$, where N_i is the confined particle inventory, and Γ_{gas} is the gas injection rate. In the SGI fueling experiments, typical fueling efficiency values inferred from the plasma electron inventory analysis were in the range 0.1 - 0.35. The SGI fueling efficiency was found to be a function of the jet pressure (density), and a weak function of the plasma - SGI distance. The SGI was used to fuel H-mode plasmas, and reliable H-mode access was obtained. Good progress was also made toward a controlled density SGI-fueled H-mode plasma scenario with the flow rate of the uncontrolled HFS gas injector reduced by up to 20. As a result, comparable or slightly higher core and pedestal densities were obtained, with 5 - 15 % reduction of core and pedestal temperatures, and a change in the ELM character from Type I and small, Type V ELMs to Type III ELMs. The SGI was operated with deuterium in these experiments since the gas delivery configuration was common to the NSTX HFS gas injection system.

These results motivated a number of upgrades of the SGI, its gas delivery system, and control elements, namely: 1) to increase the available plenum pressure to 5000 Torr (100 PSIA), thus increasing the jet pressure and the flow rate, 2) to increase the plenum pressure volume, 3) to change the gas delivery system to allow for injection of various gases, other than deuterium, and 4) to enable multi-pulse capability for better fueling control. This paper describes the upgrade work and initial results obtained with SGI-Upgrade (SGI-U).

II. UPGRADES

Increasing the SGI plenum pressure from 2500 Torr to 5000 Torr required a number of modifications to mechanical and electrical gas system components. Various system aspects were considered during the SGI-U design: gas tube routing around the NSTX vacuum vessel, high-pressure gas pump-out solutions, remote regulation and measurement of the SGI-U plenum pressure, electrical isolation and proper grounding of the SGI hardware, and overall system control. Characterizing and understanding the nozzle and valve performance at higher pressure were also considered a high priority element of the SGI-U upgrade work. These efforts are described in the following subsections.

A. SGI and gas delivery system modifications

The SGI design and operation have been previously described [3]. The SGI-U design retained the existing hardware

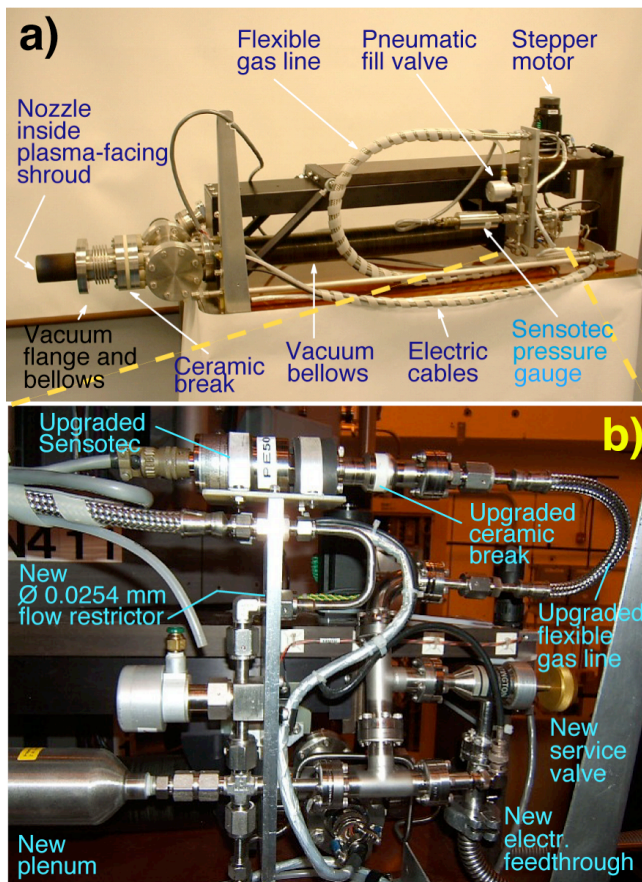

Fig. 1. Photographs of the supersonic gas injector (a) and an enlarged view of the upgraded SGI (b). Highlighted in light blue are the components upgraded to handle 100 PSIA pressure.

components rated for a 5000 Torr (100 PSIA) operation. Shown in Fig. 1 are the photographs of the SGI and SGI-U apparatus. In the SGI-U design, all original 12.5 mm OD stainless steel gas lines and joints were retained. At pressures $P \leq 5000$ Torr, the gas flow is in the viscous (Poiseuille) flow regime, where a viscous boundary layer effect due to flow shear at the wall is non-negligible. Because of the boundary layer the flow rate Q_m is a linear function of the pressure P even for sonic laminar pipe flows, deviating from the ideal Poiseuille flow regime ($Q_m \sim P^2$) [7]. The boundary layer thickness is independent of flow pressure once the flow reached the viscous regime. Therefore, the SGI-U gas system performance is expected to be similar at both 2500 Torr and 5000 Torr. A supersonic nozzle flow rate is also linearly proportional to plenum pressure. To reduce the effect of a flow rate reduction with a plenum pressure drop during SGI gas pulses in one plasma discharge, a larger gas reservoir was considered. Previously, when a plenum volume of 125 cc was used, a reduction in the flow rate by 10-15 % was observed. A new calibrated plenum volume of 150 cc (Fig. 1) was added to the system. The new effective SGI-U plenum volume, taking into account other changes, was estimated to be 250 cc. Several SGI components have been upgraded to high pressure-rated (100-200 PSIA) models. The upgraded components (highlighted in Fig. 1) included: CeramTech ceramic breaks (used

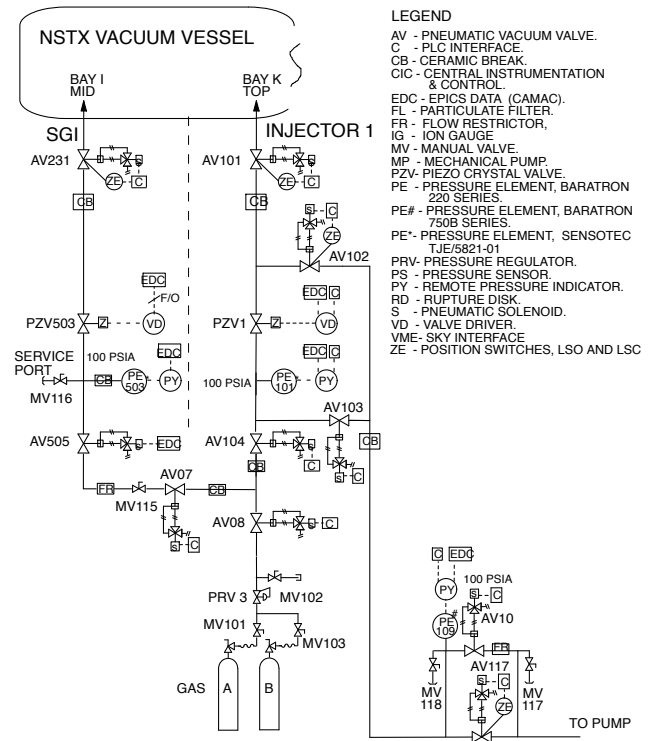

Fig. 2. Schematic of the SGI-U gas delivery system.

for electric isolation), a flexible hose, an electric feedthrough, a 0.0254 mm ID orifice (serving as a flow restrictor), and a pressure transducer (Sensotec Model TJE AP122BR). The diagnostics mounted on the SGI head - a single Langmuir probe, a thermocouple, and magnetic pick-up coils - have not been modified.

Most changes have been concerned with the gas delivery system. Previously, the SGI gas line was connected to the NSTX Lower Dome and Inner Wall gas system [8]. Standard gas bottles with a maximum pressure of 2500 Torr imposed by hardware limits and limited by a gas regulator were used. The SGI-U design goals required an independent high-pressure-rated gas delivery and pump-out system. A cost and labor effective solution was found: a gas delivery system of one of the existing (conventional) gas injectors was modified and connected to the SGI-U. Most of the existing hardware infrastructure, computer and PLC controls were retained. The upgrades included ceramic breaks, flexible bellows, and an addition of two new pneumatic isolation Nupro valves. Sensotec pressure transducers were replaced and a Baratron pressure gauge was added. On the gas cylinder end, upgrades involved replacing gas cylinder regulators by 200 PSIG rated models (Matheson Tri-Gas Model 3122 dual stage regulator). The pump-out system was modified to include a by-pass with a flow restrictor to avoid overloading the NSTX mechanical pump with high pressure gas. These changes are reflected in the SGI-U gas delivery system schematic shown in Fig. 2. The design enables filling the SGI-U remotely with any gas from gas bottle A, while operating the conventional gas injector (Injector 1) at a different pressure up to 5000 Torr with gas

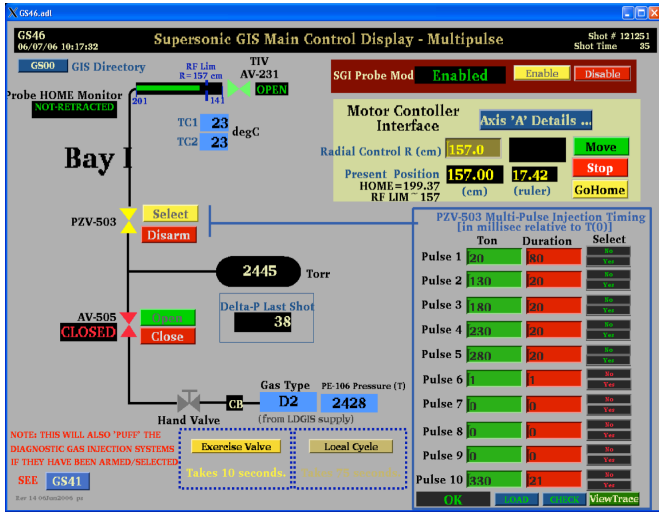

Fig. 3. EPICS software interface page used to operate and control SGI-U.

from bottle B.

The EPICS system [9] was used for SGI control, operation and PLC functions. An EPICS software interface is run on a terminal in the NSTX control room. Computer controls and PLC functions and events were modified to reflect the hardware changes described above. A multi-pulse capability was also added. It is now possible to use up to ten pulses in one plasma discharge (compared to one SGI pulse per a NSTX plasma discharge previously). Shown in Fig. 3 is the EPICS software interface used to operate and control the SGI-U. An SGI-U operator specifies the radial location of the SGI-U head, and executes the SGI-U probe motion. The probe is usually kept at $R = 1.98$ m when unused, and at $R = 1.52 - 1.60$ m (several cm from plasma) during plasma operations. The operator also specifies the plenum fill pressure and the pulses start time and duration, and controls the fill and pump out functions of the gas delivery system. The SGI-U operation is synchronized with the NSTX discharge (shot) clock cycle. Manual pulsing for test or calibration purposes is also possible.

B. Nozzle and valve characterization at high pressure

A converging-diverging de Laval nozzle is used in the NSTX SGI. Previously reported laboratory testing of the nozzle performance included supersonic gas jet characterization and total flow rate measurements [1], [2] at pressures $P_0 \leq 2500$ Torr in hydrogen, deuterium and helium. A Mach number of about 4 and a jet divergence half-angle between $5 - 25^\circ$ have been measured in deuterium and hydrogen. Using the isentropic relations between stagnation and static quantities the density at the nozzle exit was estimated to be $\rho \leq 10^{18} \text{ cm}^{-3}$, and the temperature to be $T \geq 70$ K.

Nozzle and piezoelectric valve performance at higher pressures has been studied. Measured flow rates were found to be linear functions of plenum pressure for a stand-alone Veeco PV-10 valve and for an assembly of the valve and nozzle, consistent with previously measured rates [3]. At the deuterium plenum pressure of 2500 Torr, the SGI-U flow rate

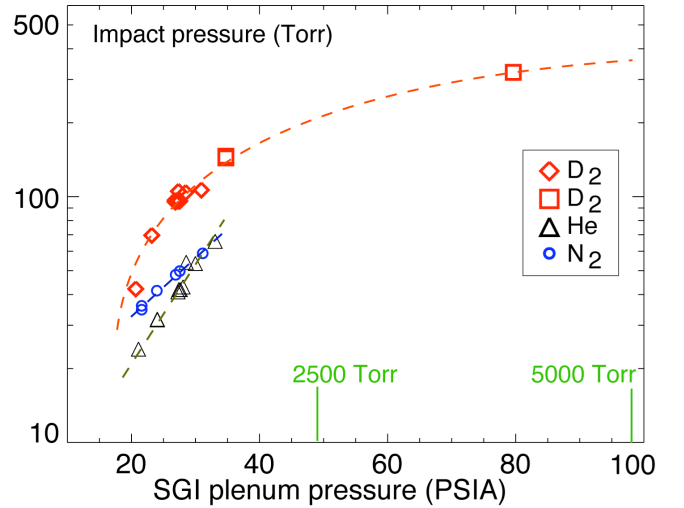

Fig. 4. Supersonic gas jet impact pressure as a function of plenum pressure for deuterium, helium and nitrogen. Lines are drawn to guide the eye.

was 60-65 Torr l / s, while at 5000 Torr, the flow rate was about 120-130 Torr l / s. To characterize performance of a supersonic gas jet, impact pressure P_i measurements at the nozzle exit as a function of plenum (stagnation) pressure P_0 were performed with deuterium, helium and nitrogen (Fig. 4). Deuterium injection at rates $Q \leq 120$ Torr l / s is used in NSTX for fueling, whereas helium and nitrogen injection at rates $Q \leq 5 - 10$ Torr l / s can be used for diagnostic purposes, or in transport and radiative divertor experiments. The Mach number M_d inferred from the P_i measurements using the supersonic Rayleigh-Pitot law was about 4 for a full range of available P_0 pressures in deuterium, since the ratio P_0/P_i changed proportionally with P_0 . The Mach number M appeared to be slightly higher for helium and nitrogen at lower P_0 pressures. The observed independence of M from the plenum pressure P_0 is interpreted as confirmation of the supersonic flow regime: the boundary layer does not change significantly with pressure, and an isentropic jet core exists in a range of pressures.

III. INITIAL EXPERIMENTS ON NSTX

The radial propagation of a high-pressure gas jet through the edge plasma is determined to the first order by the fluid momentum and energy balance, mainly by the relative magnitude of the plasma magnetic and kinetic pressure, and the gas jet pressure. The gas jet undergoes molecular and atomic (dissociation, charge exchange, ionization) reactions as it propagates through the scrape-off layer, retaining a neutral core shielded by an ionizing layer. The gas jet density plays a critical role in the penetration mechanism, as has been recently demonstrated by analytic and numerical modeling [10]–[12]. However, a deep penetration appears to be inhibited by a high-density ionizing plasmoid rapidly developing in front of the gas jet and blocking the jet from further penetration.

Initial fueling experiments with SGI-U have been carried out on NSTX. Deuterium was injected in the L and H-mode phase of a discharge. High-speed camera visualizations (Fig. 5) of the SGI-U jet interactions with edge plasma qualitatively

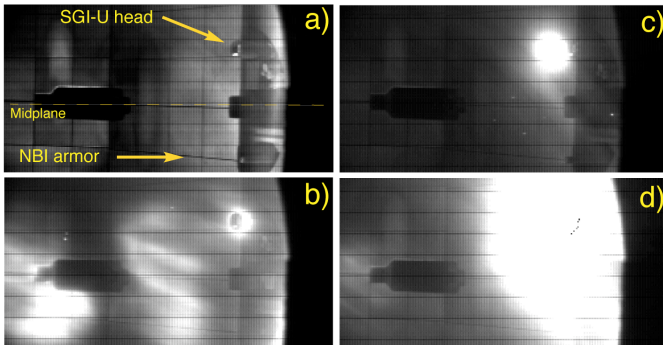

Fig. 5. Fast camera images of SGI-U operation: (a) SGI-U head in the vacuum vessel at $R = 157$ cm, (b) Plasma interaction with SGI-U head during an MHD event, (c) D_{α} emission from high-pressure deuterium jet in the initial phase of injection, (d) D_{α} emission during high-pressure deuterium pulse (camera saturated).

looked similar to the previous SGI observations [3]. However, the light intensity, mostly a D_{α} emission, was much higher than previously observed (up to a camera saturation level), an indication of a higher jet density and possibly a higher penetration (i.e. emission at higher edge electron densities). As in SGI fueling experiments, the high-pressure SGI-U injection did not lead to an H-L transition. Shown in Fig. 6 are the waveforms of a 4-6 MW NBI heated H-mode discharge. In this experiment, reduced HFS fueling was used (500 Torr plenum pressure vs 900-1200 Torr typically used). The SGI-U was operated at a plenum pressure of 5000 Torr and at a major radius of 157 cm, about 5-10 cm from the plasma last closed flux surface. The H-mode transition occurred at 0.26 s, so that the first SGI-U pulse was injected in the L-mode, while two subsequent pulses were in the H-mode phase of the discharge. The SOL density did not change during the SGI-U pulses, while the inboard and outboard pedestal density increased, suggesting high jet penetration characteristics and particle deposition in the edge/pedestal region. The total electron inventory $N_e(t) = \int n_e dV$ also increased during the SGI-U pulses as evident from its time derivative dN_e/dt . However, the edge particle confinement time appeared to be low ($\tau \leq 10$ ms) as the deposited particles were quickly lost from the plasma. From the initial experiments, the SGI-U fueling efficiency was estimated to be 0.1 - 0.3, comparable to the SGI fueling efficiency obtained at lower pressures. This result may imply that the present supersonic gas jet characteristics are at a physical performance limit, and a higher fueling efficiency w.r.t. a conventional gas injection is mostly due to a geometric focusing effect. Experiments and modeling are planned to further study the SGI-U fueling characteristics.

IV. SUMMARY AND FUTURE WORK

In summary, recently implemented upgrades transformed the SGI into a versatile apparatus for fueling and diagnostic applications on NSTX. All hardware and control software modifications have been commissioned and performed as expected. Initial experiments demonstrated the SGI-U fueling compatibility with H-mode plasmas, and fueling efficiency in the range 0.1 - 0.3. Future NSTX experiments will focus on

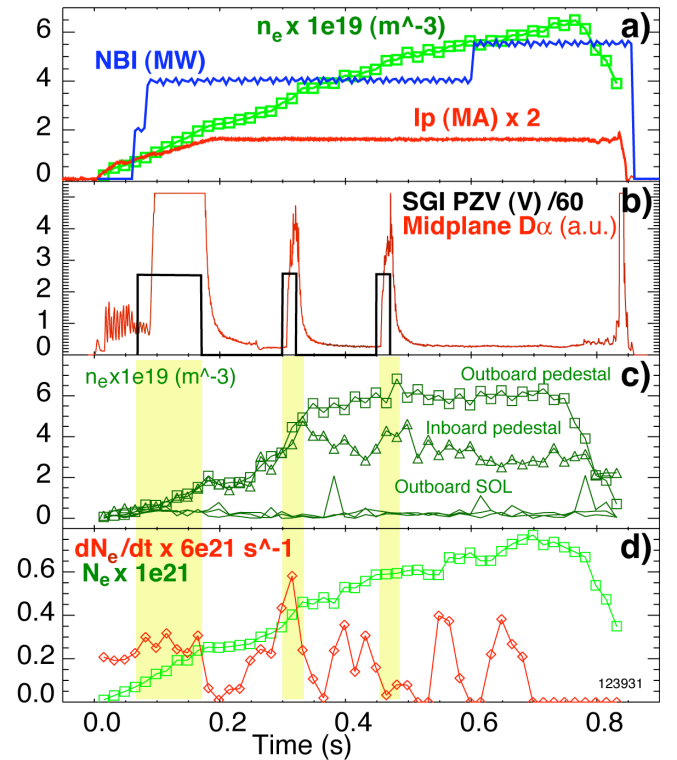

Fig. 6. Time traces of a representative SGI-U-fueled H-mode discharge: (a) Plasma current I_p , NBI power, line-averaged density \bar{n}_e , (b) Midplane D_{α} emission, SGI-U valve control voltage, (c) Electron density measured by the Thomson scattering system in the SOL and at the H-mode pedestal (inboard and outboard), (d) Total electron inventory, and its time derivative.

development of high-performance plasma scenarios with supersonic gas jet fueling, and H-mode pedestal fueling studies. Laboratory tests of the conic and converging nozzle geometries and cryogenic nozzles are planned in an effort to simplify the design and improve gas jet fueling characteristics.

ACKNOWLEDGMENTS

We thank T. Czeizinger, J. Desandro, J. Gething, L. Gut-tadora, J. Kukon, D. Labrie, T. Holoman, C. Priniski, and J. Winston for technical support. NSTX team is acknowledged for plasma, NBI and diagnostic operations.

This work is supported by U.S. DoE under Contracts No. W-7405-Eng-48 and DE-AC02-76CH03073.

REFERENCES

- [1] V. A. Soukhanovskii et al., *Rev. Sci. Instrum.*, vol. 75, p. 4320, 2004.
- [2] V. A. Soukhanovskii et al., in *Proc. 31st EPS Conf. on Plasma Physics*, vol. ECA 28G, London, UK, 2004, pp. P-2.190.
- [3] V. A. Soukhanovskii et al., in *Proc. 21st IEEE/NPSS Symposium on Fusion Eng.* Knoxville, TN: IEEE, September 2005.
- [4] R. Majeski et al., in *Proc. of 21st Fusion Energy Conference*. Chengdu, China: IAEA, October 2006, pp. EX/P4-23.
- [5] H. W. Kugel et al., *J. Nuc. Mater.*, vol. 363-365, p. 791, 2007.
- [6] V. A. Soukhanovskii et al., *J. Nuc. Mater.*, vol. 313, p. 573, 2003.
- [7] S. C. Bates and K. H. Burrell, *Rev. Sci. Instrum.*, vol. 55, p. 934, 1984.
- [8] H. W. Kugel et al., in *Proc. 20th IEEE/NPSS Symposium on Fusion Eng.* San Diego, CA: IEEE, October 2003.
- [9] P. Sichta and J. Dong, in *Proc. 19th IEEE/NPSS Symposium on Fusion Eng.* Atlantic City, NJ: IEEE, January 2002, p. 245.
- [10] Y. Jiao et al., *Plasma Phys. Control. Fusion*, vol. 45, p. 2001, 2003.
- [11] P. T. Lang et al., *Plasma Phys. Control. Fusion*, vol. 47, p. 1495, 2005.
- [12] V. Rozhansky et al., *Nuc. Fusion*, vol. 46, no. 2, pp. 367-382, 2006.