

Introduction and Previous PAC Recommendations

by
T.S. Taylor

Presented to the
DIII-D Program Advisory Committee
San Diego, California

February 15–17, 2011

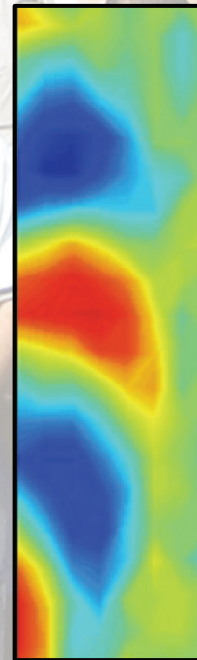
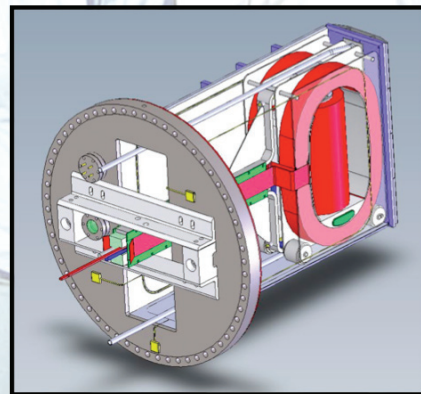
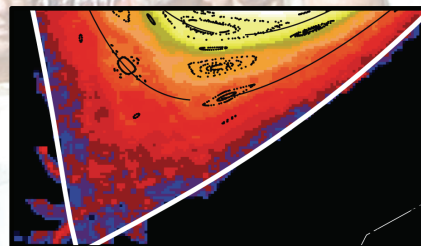

Outline

- **Introduction to DIII-D Program**
 - Role of the DIII-D Program
 - Status
- **Charge to the Program Advisory Committee**
- **Review of 2010 PAC recommendations**

DIII-D Program Objectives are Strongly Aligned with FES Initiatives

- **ITER**

- ITER introduces a new era in fusion research: burning plasma physics
- Achievement of ITER's objectives is critical to the success of fusion worldwide

- **Fusion Simulation Program**

- Presently, in 2 year “definition phase”
- Vision: “FSP will provide the capability to confidently predict toroidal magnetic confinement fusion device behavior with comprehensive and targeted science-based simulations...”

- **Fusion Nuclear Science Pathways Assessment**

- Initiated July, 2010
- Launching of a vigorous materials and nuclear science program that will be part of defining and constructing a fusion nuclear science facility, and will fill gaps on route to a DEMO

DIII-D Addresses Key R&D Needs for ITER

Urgent near-term research

- TBM mockup
- ELM control
- Disruption mitigation

Physics basis

- L-H transition
- Pedestal height
- Fast ion physics
- Transport, ITER-like conditions

Scenario development

- Reference scenarios
- Non-nuclear plasma
- Steady-state scenarios

Control solutions

- Heat & particle flux
- MHD stability
- Integrated SS control

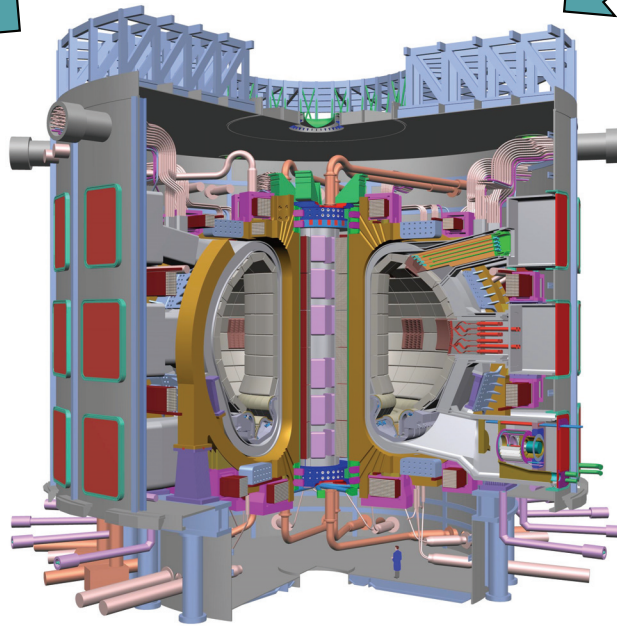

ITER support remains highest priority in the DIII-D research program

A Vital Role of DIII-D: Test and Validate State-of-the-Art Physics Models, Supporting the Fusion Simulation Program

- DIII-D has a rich history of testing sophisticated physics models at multiple levels of detail
 - Strong collaborative effort
- Enabled by a comprehensive diagnostic set capable of high fidelity measurements ...
 - Profiles (core, SOL, divertor, 1D, 2D)
 - Extensive fluctuation measurements
- Extensive configuration flexibility allowing test of key parameters
 - Plasma shape (SN, DN, δ , κ)
 - Wide range of rotation, T_e/T_i , collisionality, heating/CD sources

Gyrofluid simulation

(TAE/FL)

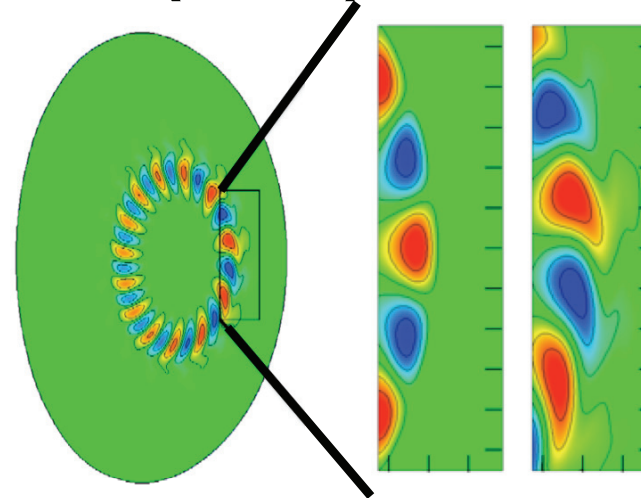

Measurement

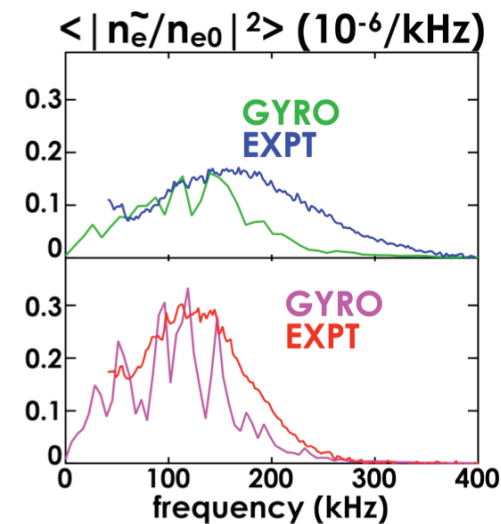
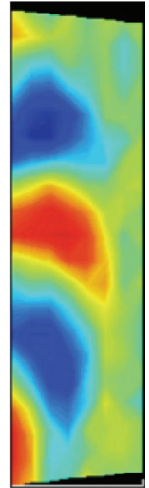

$\rho=0.6$

NBI only

$T_e \approx T_i$

NBI+ECH

$T_e > T_i$

Mission Elements of a Fusion Nuclear Science Facility

— Our Perspective —

- **FNSF will**
 - Produce significant **fusion power** (100–300 MW) in steady-state
 - Show fusion can **make its own fuel**
 - Show fusion can produce high grade **process heat and electricity**
 - Provide a **materials irradiation facility** to develop low activation, high strength, high temperature, radiation resistant materials
 - Enable research on **high performance, steady-state, burning** plasmas for Demo
- **By operating steady-state with**
 - Modest energy gain
 - Operate 30% of a year in **2 week** periods
 - Significant neutron fluence (**3–6 MW-yr/m², 30–60 dpa**)

Two Candidates

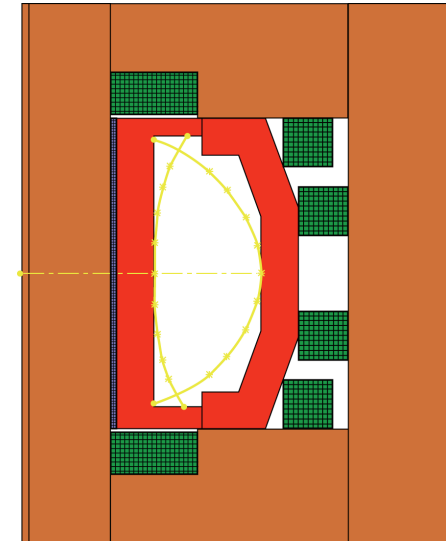

FNSF-AT (FDF)

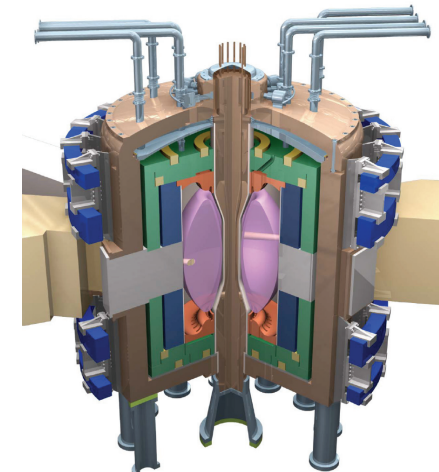

FNSF-ST (ST-CTF)

Mission Elements of a Fusion Nuclear Science Facility

— Our Perspective —

- **FNSF will**

- Produce significant **fusion power** (100–300 MW) in steady state

Key Role of DIII-D

FNSF operational scenarios

Provide the physics basis for steady-state, high average power operation

- **By operating steady-state with**

- Modest energy gain
- Operate 30% of a year in **2 week** periods
- Significant neutron fluence (**3–6 MW-yr/m², 30–60 dpa**)

Two Candidates

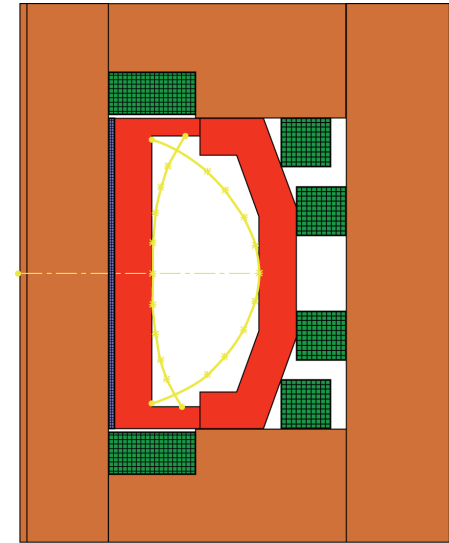

FNSF-AT (FDF)

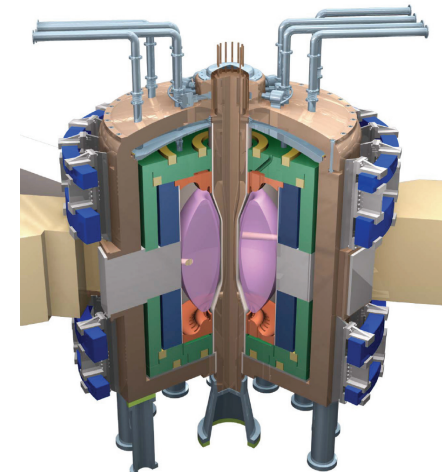

FNSF-ST (ST-CTF)

DIII-D Research Directions In Support of Fusion Energy Development

– Optimize Steady State Scenario for ITER, FNSF, and DEMO –

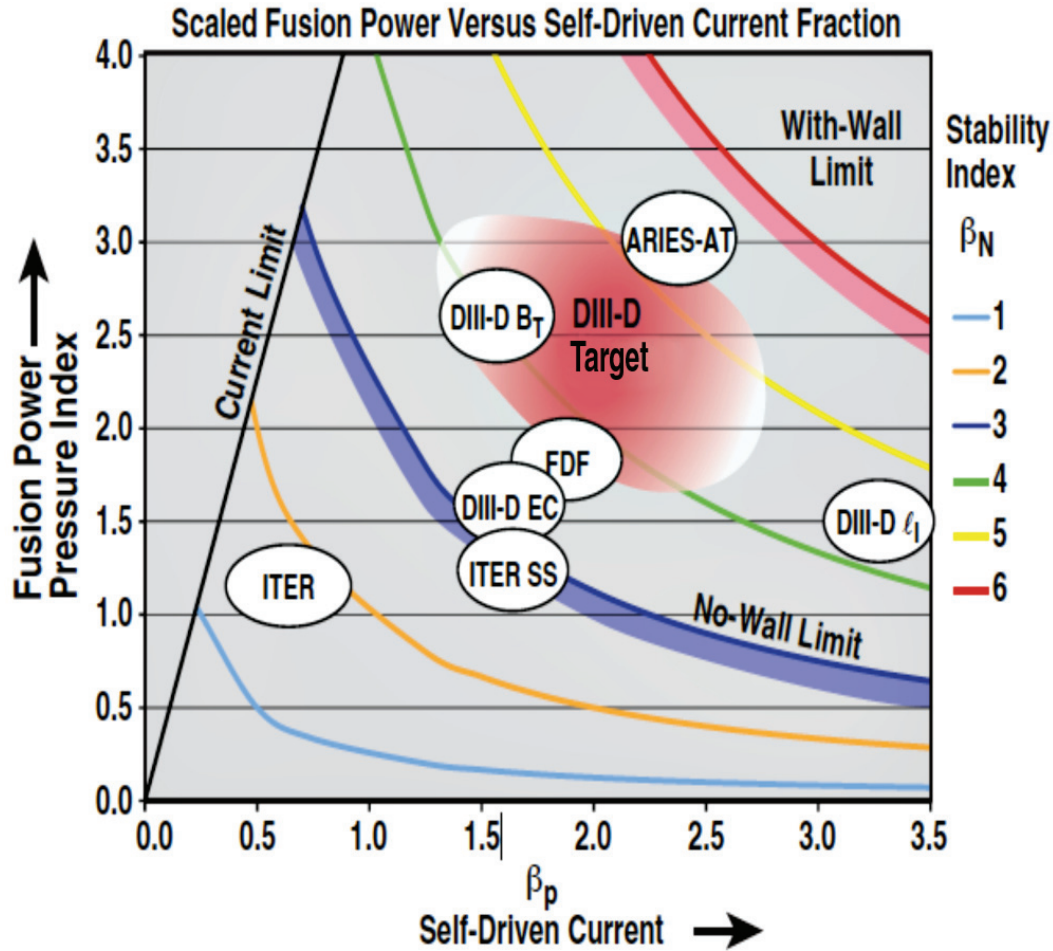

- **Research on DIII-D will**

- Optimize ITER SS $\beta_N < 3$
- Develop FDF (FNSF-AT) scenarios, $\beta_N \sim 4$
- Extend SS scenarios to power plant, $\beta_N > 5$

DIII-D directions

- Off-axis current drive and profile control
- Electron heating
- Low torque
- 3D fields

DIII-D is Playing a Key Role in the Path Towards Fusion Energy

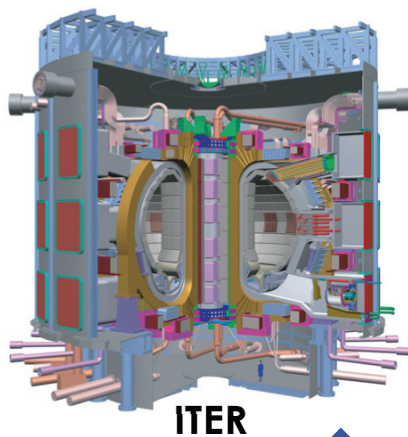

ITER

Viability of α -heated plasma,
 Plasma and plant operation at reactor scale
 Integrated plasma and control solutions
 Control of transients

Fusion Nuclear/Materials Program

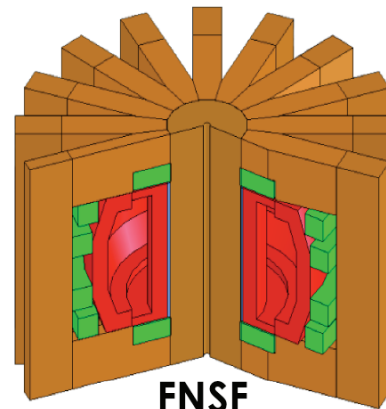

FNSF

Resolve nuclear & high heat fluence materials
 Make fusion fuel
 Extract fusion power
 Continuous steady state operation
 Steady-state high heat flux exhaust

DIII-D key roles

Develop operating regimes
 Physics validation
 Transient avoidance and control
 Develop integrated control technologies

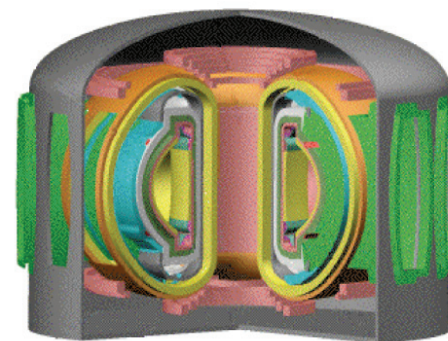
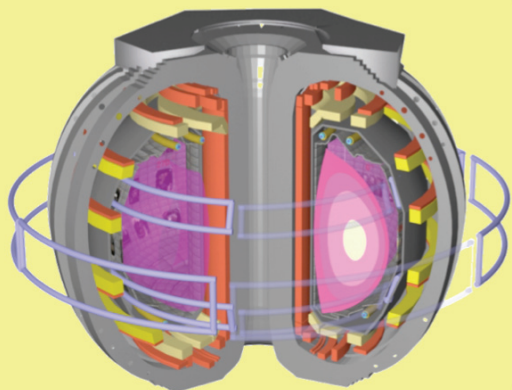

Power Plant

Fully self-driven regimes
 High energy gain
 Very high β stability
 Optimal current configuration
 Control solutions for self-driven plasma

DIII-D Status

- **DIII-D is engaged in a Long Torus Opening (LTO II) for facility enhancements**
 - Reorient one neutral beam line (5 MW) for off-axis deposition and current drive at $r/a \approx 0.5$ [Kellman]
 - Preparing 7th gyrotron (ARRA) – available FY12
 - Completing a high voltage P/S (ARRA), capable of powering two gyrotrons or one neutral beam ion source
 - New diagnostics (partially ARRA) [Boivin]
- **Vessel closure planned March 18, 2011**
- **Physics operations planned May 9, 2011**

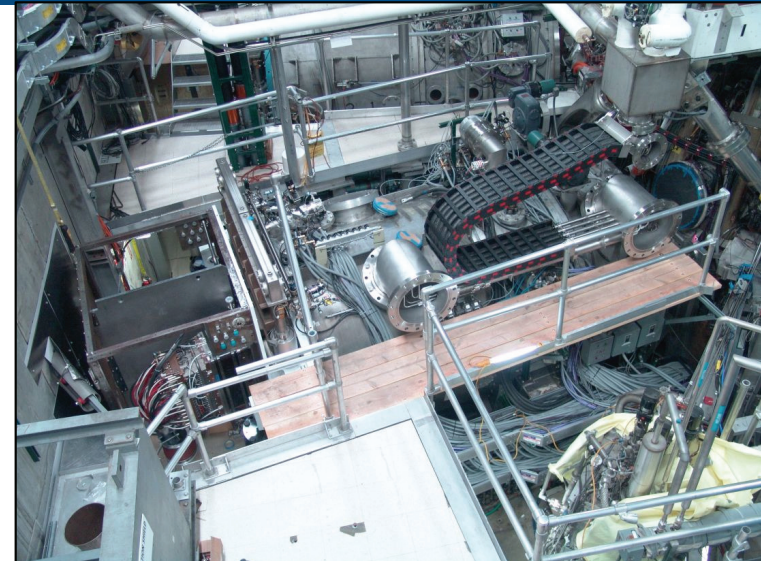

14 Weeks Physics Operation Planned in FY2011

10 Weeks Operation Planned in FY2012

PROPOSED DIII-D FY2011 OPERATIONS SCHEDULE																													
Oct							Nov							Dec							Jan								
S	M	T	W	T	F	S	S	M	T	W	T	F	S	S	M	T	W	T	F	S	S	M	T	W	T	F	S		
					1	2		1	2	3	4	5	6				1	2	3	4								1	
3	4	5	6	7	8	9	7	8	9	10	11	12	13	5	6	7	8	9	10	11	2	3	4	5	6	7	8		
10	11	12	13	14	15	16	14	15	16	17	18	19	20	12	13	14	15	16	17	18	9	10	11	12	13	14	15		
17	18	19	20	21	22	23	21	22	23	24	25	26	27	19	20	21	22	23	24	25	16	17	18	19	20	21	22		
24	25	26	27	28	29	30	28	29	30					26	27	28	29	30	31		23	24	25	26	27	28	29		
31																					30	31							
Feb							Mar							Apr							May								
S	M	T	W	T	F	S	S	M	T	W	T	F	S	S	M	T	W	T	F	S	S	M	T	W	T	F	S		
		1	2	3	4	5		1	2	3	4	5					1	2		1	2	3	4	5	6	7			
6	7	8	9	10	11	12	6	7	8	9	10	11	12	3	4	5	6	7	8	9	8	9	10	11	12	13	14		
13	14	15	16	17	18	19	13	14	15	16	17	18	19	10	11	12	13	14	15	16	15	16	17	18	19	20	21		
20	21	22	23	24	25	26	20	21	22	23	24	25	26	17	18	19	20	21	22	23	22	23	24	25	26	27	28		
27	28						27	28	29	30	31			24	25	26	27	28	29	30	29	H	31						
Jun							Jul							Aug							Sep								
S	M	T	W	T	F	S	S	M	T	W	T	F	S	S	M	T	W	T	F	S	S	M	T	W	T	F	S		
			1	2	3	4					1	2		1	2	3	4	5	6								1	2	3
5	6	7	8	9	10	11	3	H	5	6	7	8	9	7	8	9	10	11	12	13	4	5	6	7	8	9	10		
12	13	14	15	16	17	18	10	11	12	13	14	15	16	14	15	16	17	18	19	20	11	12	13	14	15	16	17		
19	20	21	22	23	24	25	17	18	19	20	21	22	23	21	22	23	24	25	26	27	18	19	20	21	22	23	24		
26	27	28	29	30			24	25	26	27	28	29	30	28	29	30	31				25	26	27	28	29	30			
							31																						

PROPOSED DIII-D FY2012 OPERATIONS SCHEDULE																													
Oct							Nov							Dec							Jan								
S	M	T	W	T	F	S	S	M	T	W	T	F	S	S	M	T	W	T	F	S	S	M	T	W	T	F	S		
						1																							
2	3	4	5	6	7	8	6	7	8	9	10	11	12	4	5	6	7	8	9	10	8	9	10	11	12	13	14		
9	10	11	12	13	14	15	13	14	15	16	17	18	19	11	12	13	14	15	16	17	15	16	17	18	19	20	21		
16	17	18	19	20	21	22	20	21	22	23	H	H	26	18	19	20	21	22	23	24	22	23	24	25	26	27	28		
23	24	25	26	27	28	29	27	28	29	30				25	26	27	28	29	30	31	29	30	31						
30	31																												
Feb							Mar							Apr							May								
S	M	T	W	T	F	S	S	M	T	W	T	F	S	S	M	T	W	T	F	S	S	M	T	W	T	F	S		
			1	2	3	4							1	2	3	1	2	3	4	5	6	7							
5	6	7	8	9	10	11	5	6	7	8	9	10	11	4	5	6	7	8	9	10	8	9	10	11	12	13	14		
12	13	14	15	16	17	18	11	12	13	14	15	16	17	15	16	17	18	19	20	21	13	14	15	16	17	18	19		
19	H	21	22	23	24	25	18	19	20	21	22	23	24	22	23	24	25	26	27	28	20	21	22	23	24	25	26		
26	27	28	29				25	26	27	28	29	30	31	29	30						27	H	29	30	31				
Jun							Jul							Aug							Sep								
S	M	T	W	T	F	S	S	M	T	W	T	F	S	S	M	T	W	T	F	S	S	M	T	W	T	F	S		
						1								1	2	3	H	5	6	7								1	
3	4	5	6	7	8	9	8	9	10	11	12	13	14	5	6	7	8	9	10	11	2	H	4	5	6	7	8		
10	11	12	13	14	15	16	15	16	17	18	19	20	21	12	13	14	15	16	17	18	9	10	11	12	13	14	15		
17	18	19	20	21	22	23	22	23	24	25	26	27	28	19	20	21	22	23	24	25	16	17	18	19	20	21	22		
24	25	26	27	28	29	30	29	30	31					26	27	28	29	30	31		23	24	25	26	27	28	29		

■ Plasma physics
 ■ Startup
 ■ Option
 ■ Vent

■ Plasma physics
 ■ Startup
 ■ Option
 ■ Vent

• New Capabilities

Off-axis NBI
(2011)

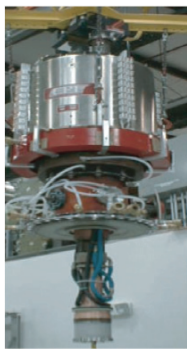
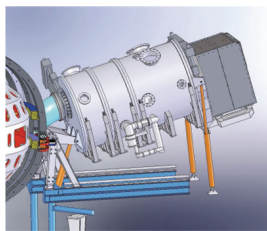

7 EC gyrotrons
(2012)

TBM Experiments

Planned
September 6–23

Some Important Events Since Last PAC

- **Center post RMP coil project was stopped**
- **Fusion Energy Sciences has endorsed procurement of the 1.5 MW gyrotron**
 - GA corporate funded the design of a 1.5 MW 117.5 GHz gyrotron
 - GA and PPPL have agreed to jointly fund the 8th gyrotron (1.5 MW) for DIII-D
 - Expect to be operational for FY13 experiments
- **New ITER management**
 - Final design process placing increased emphasis on ELM control coil decision for ITER (~June, 2012)
- **Fusion Nuclear Science Pathway Assessment initiated by FES**



Center Post RMP Coil Project was Stopped

- **Thorough physics review of the project [Wade]**
 - Difficulty to meet objectives with a reduced set of coils (36 → 12-18)
 - Many scientific opportunities remain with present coil set and new diagnostics
- **With GA, PPPL and FES concurrence, DIII-D stopped work on the center post coil (RMP) project**
 - Cost
 - Schedule delay
 - Technical difficulty
 - Remaining scientific opportunities
- **The DIII-D program agreed to maintain a strong physics effort on ELM suppression and 3D field effects**
 - Refocus efforts on ELM suppression to understanding the underlying physics
 - Re-evaluate in two years (2012) the need for additional 3D coils in DIII-D

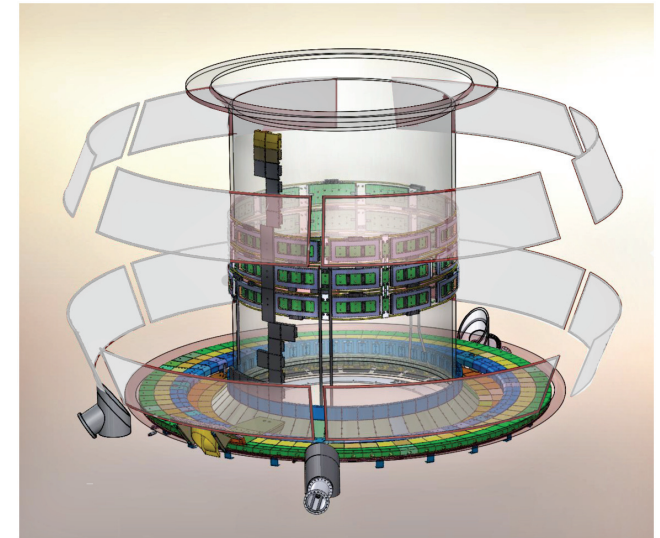

Charge 1: Content and Balance of Near-term Research Goals and Plans

DIII-D will be resuming physics experiments in May following a one-year shutdown (LTO-II) to modify one beamline for off-axis neutral beam injection, prepare for the addition of a 7th gyrotron, and complete a number of diagnostic upgrades. With these new capabilities, experimental progress and input from community planning processes and DOE, we are developing and reviewing our program plan going forward. We ask the DIII-D Program Advisory Committee to comment on our goals and plans, the associated path towards achieving them, and the overall program balance in light of research needs for ITER and the Fusion Nuclear Science Program now under assessment.

Charge 2: ELM Control and Pedestal Physics

Two areas of research will take on increased importance during the next year: (a) ELM control with 3D fields because of the urgent ITER decision on internal RMP ELM coils, and (b) pedestal physics, the focus of the 2011 Joint Research Target.

Since the last PAC meeting, DIII-D management decided to forego installation of non-axisymmetric coils on the center-post (CP-coils) during the LTO II. Subsequently, we have examined how best to utilize existing resources to advance the physics understanding of ELM control with 3D fields. We have held several workshops to engage theorists and modelers in both the impact of 3D fields for ELM control, and the physics mechanisms responsible for the structure of the pedestal. We are improving and adding new diagnostic measurements to assist in these efforts. DIII-D is also evaluating alternate ELM control techniques that might be applied to ITER.

We invite the Program Advisory committee to comment on our research plans in each of these areas. Please provide advice on how the DIII-D Program can best advance our physics understanding on the mechanisms responsible for the structure of the H-mode pedestal; and of ELM control with 3D fields and the extrapolation to ITER Conditions.

Response to 2010 PAC Recommendations

DIII-D Program greatly appreciates the advice from the Program Advisory Committee, and takes that advice seriously in developing our plans for the future

- **Map out accessible parameter space. Compare multiple transport channels (i.e., assess $v_{ei} \tau_E$)**
 - Ions and electrons decouple as EC power is raised [Buttery]
 - Ion and electron transport evaluated for experimental data over range of current profiles (Ferron IAEA, Greenfield IAEA) [Greenfield]
- **Develop a consistent plan for needed upgrades with technical results and criteria for upgrade decisions**
 - 2nd off-axis NBI: physics evaluation, 2011; beam line inspection, 2012; Decision to proceed based on the successful off-axis deposition and CD, and hardware integrity
 - Fast wave: physics and hardware assessment, CY 2011
Decision to proceed based primarily on successful heating of high performance H-mode
 - Divertor: modest modification required for 300 MJ [Kellman]
We expect evaluation (and potential modification) as part of the next 5 year cooperative agreement (2014–2018)

- **Develop robust diagnostic for edge current profile**
 - Upgraded Li beam, commission and resume operation in FY11
 - MSE, evaluating improved spectral filtering to reduce systematic errors and noise, late 2011, 2012
- **Develop diagnostics for effect of RMP**
 - X-point soft x-ray (ORNL) available in 2011 [Boivin]
 - Additional off-midplane probes 2011
 - 3D magnetics planned for 2013
 - 3D diagnostic task force formed to evaluate new diagnostic effort (PPPL)

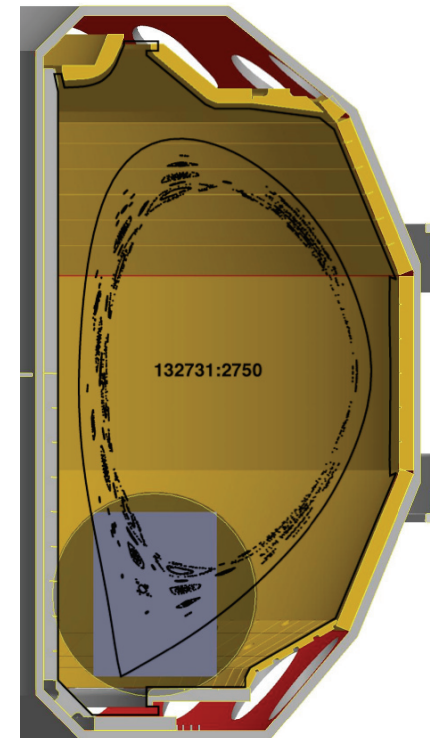

- **Develop and test more accurate models of 3D field effects**
 - Proactive outreach to theory community to develop testable models [Wade, Turnbull]
 - Program plan includes model parametric scans, and tests of 3D magnetic response and transport [Wade]
- **Devise method to visualize magnetic islands**
 - Main new diagnostic is X-point soft x-ray [Boivin]
- **Increase connections to stellarator program on 3D physics**
 - Engaging stellarator community in 3D equilibria (ORNL, PPPL) [Turnbull]
 - Initiated collaboration with LHD, which has RMP coils + 3D fields
Evans participated in LHD experiments in January
 - EMC3-EIRENE, a fluid code developed for W7AS/W7X, is being used to analyze DIII-D data

- **PACKET**

- **Determine and look for experimental signatures for unstable KBMs**
 - Data from BES looks promising [Yan APS] [Greenfield]
 - Program plan emphasizes more detailed scans and diagnostic measurements [Snyder]
- **Use new diagnostic capabilities to study nonlinear evolution of pedestal plasma up to and during ELM crash**
 - Emphasized by theorists and experimentalists working on Joint Research Target
 - Important part of the experimental plan [Snyder]
 - Improved edge TS: spatial resolution, and 250 Hz [Boivin]

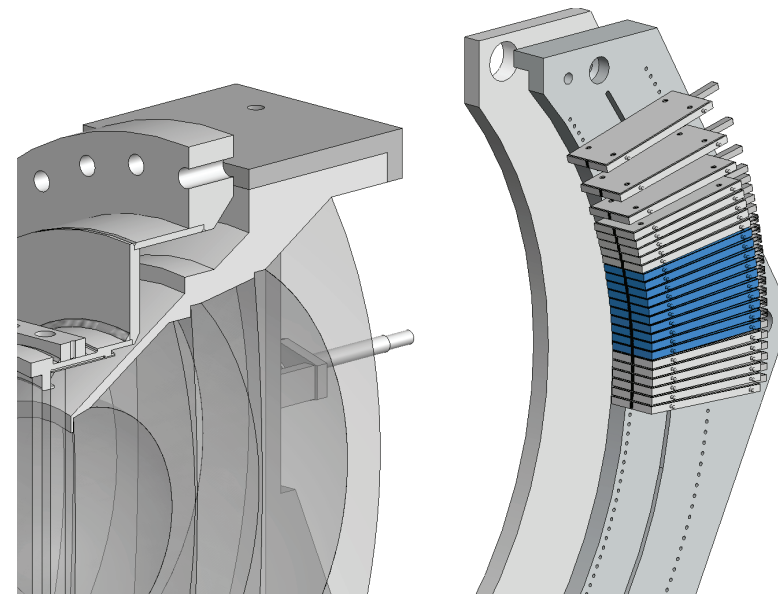

- **Please report to 2011 PAC about the balance between planned upgrades and run time for FY12**
 - Draft plan for FY12 is 10 run weeks. We will work with DOE/FES to increase experimental time if possible
 - Given the present budget uncertainty (for FY12 and FY11), we think it prudent to follow a conservative plan until more information is known
 - Planned upgrades for 2012 are
 - Install 7th gyrotron and commission
 - Begin requisition of 8th gyrotron (in collaboration with PPPL)
 - In addition, before proceeding with upgrades
 - Fast wave review planned for fall 2011, (PPPL, ORNL, GA, external)
 - Assess off-axis NBI and inspect beamline, early 2012
 - Review of non-axisymmetric physics on DIII-D, after 2012 experiments

We appreciate any support from the PAC in increasing run time on DIII-D

- **Perform further analysis of TBM results**
 - Confinement degradation in H-mode likely due to rotation decrease, and NTV due to $n=1$ is probable cause [Schaffer APS, J.K. Park IAEA]
 - Experiment proposed to test 2011 (international team) [Greenfield, Strait]
 - TBM tile heating and analysis shows differences in modeling
- **Strengthen collaborations on disruption mitigation capabilities**
 - New involvement by ITER IO, Wisconsin, MIT
- **Strengthen collaborations on plasma wall interaction and hydrogenic retention (oxygen bake)**
 - ITER diagnostic mirrors (TEXTOR), erosion and redeposition models (Purdue), fuel retention (MIT), fuel recovery (Ciemat)
- **Pursue dominant e-heating physics within context of (inter) national program**
 - Strong focus on international context with ITPA studies (scenarios, stiffness) and specific collaborations (e.g. AUG critical gradient studies)

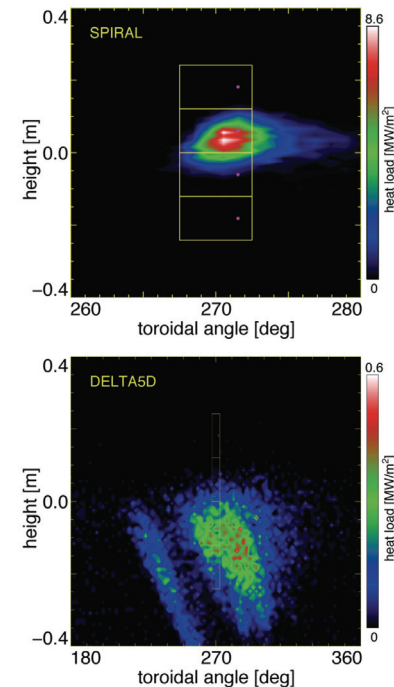

- **Address compatibility of advanced operation regimes with divertor solutions**
 - Experiments to test compatibility of radiative divertor, and ELM suppression with advanced scenarios (Petrie, IAEA)
 - Stable detached solutions, with modest density is a focus of upcoming boundary research [Leonard]
- **Address anomalous cross-field transport in model validation**
 - Continued emphasis of 2010 Joint Research Target and ITPA [Leonard]
 - Experiments on DIII-D planned with increased emphasis on turbulence
- **Analyze quantitatively C wall results (DiMES to simulate ITER erosion)**
 - Deuterium removal during O₂ bake consistent with lab results, <11% of injected D₂ retained in co-deposits [Leonard]
 - Carbon tiles to measure erosion/deposition in 2011 [Leonard]
 - Dimes experiments planned [Leonard]

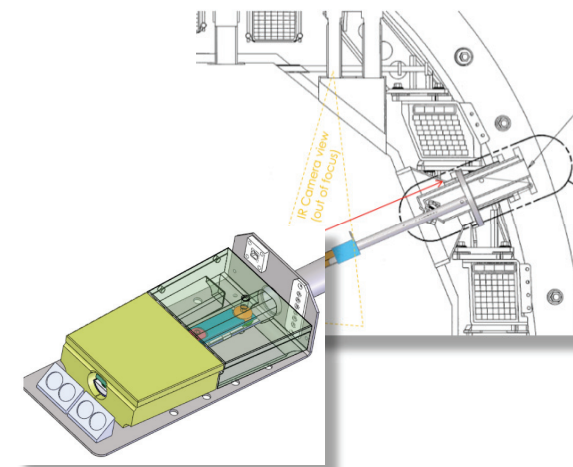

- **Identify models that can be tested to understand 3D effects and their influence on various channels**
 - Major element of 3D field research plan [Wade, Turnbull]
- **Identify specific physics elements that can be tested in edge models and design experiments accordingly**
 - Community wide effort in support of Joint Research Target [Snyder]
 - Ongoing strong effort at GA with EPED1 and KBM [Snyder]
- **Help with the definition of FSP concerning how best to address code validation**
 - DIII-D staff are engaged with FSP effort
 - Workshop at GA last week with DIII-D participation
 - Dave Hill presentation “Experimental Campaign Planning in Relation to the Fusion Simulation Program”

Disruption Research Plans

3.5

- **Assess density level required for collisional suppression or runaways; test techniques to enhance RE losses at start of thermal quench**
 - Controlled benign dissipation with shape and position control and impurity injection into controlled runaway channel [Hollmann]
 - Shell pellet injection and proof of principle rupture disc tests to improve mass delivery in 2011
- **Assess radiation and EM force asymmetries associated with disruptions and develop means to avoid them**
 - Preliminary assessment of asymmetries with shell pellet and rupture disc. Focus this year is controlled runaway dissipation
- **Explore ECH-based techniques to influence disruption properties**
 - ECH efforts are focused on prevention [Strait]
- **Develop plan to predict and mitigate disruptions not driven by beta limits**
 - Significant effort in 2011–12 on tearing modes (including NTM) and locked modes [Strait]



ID: 9.5 mm
Wall thickness: ~120 micron
Boron Mass: 0.29 gm

- **Analyze robustness of prediction when transport assumptions are varied (what portion of Δq_{\min} comes from ECCD or changed j_{BS})**
 - Experiment: pressure profiles and bootstrap current change as q_{\min} is varied
 - Stability regimes evaluated [Buttery packet]
 - Continuing to expand range of regimes and stability tests
- **Assess divertor heat load and power flux mitigation capability (since total power may exceed 20 MW in 10 s discharge)**
 - Vessel cooling capability ~300 MJ per discharge [Kellman]
 - Ongoing experimental effort, with modeling, to radiatively cool the boundary (stable detachment) [Leonard]

- **Understand and avoid confinement degradation when gas puffing or moving plasma closer to antenna are used to improve antenna coupling under ELMy H-mode conditions at low density**
 - Move antenna closer to the plasma — bumper limiters remain fixed
 - Improved antenna localized gas puffing
 - Improved antenna diagnostics for 285/300 antenna (profile reflectometer, ASDEX gauges, camera view, optical fibers)
- **Assess whether increased ELM resilience of FW system improves power coupling**
 - Improved arc/ELM discrimination
- **Contribute to validation of RF deposition codes (power split between electrons and fast ions)**
 - Will continue strong effort working with modelers on deposition
 - FY11 experiment focused on optimizing electron heating in high performance discharges — toward assessment in the fall

Fusion Nuclear Science Pathway Assessment Initiated by FES

- **19 member panel led by Charles Kessel**
- **Aim: identify and clarify requirements in materials-related research to increase fusion's credibility**
 - Builds on Greenwald Panel Report and ReNeW
- **Potential outcome: Fusion Nuclear Science Facility (FNSF) might be deployed in parallel with ITER**