

# TAE phase varies strongly with radius – Investigate cause

- Reflectometers measure **strong radial TAE phase variation**

Possible explanations for phase variation

- **Coupling to fast-ions** – predicted by code (TAE/FL in DIII-D, M3D-K in NSTX)
- **Elevation of reflectometers + broad poloidal harmonic spectrum** - predicted by NOVA-K (ideal MHD) in NSTX

Experiment: isolate cause

- Position **reflectometers in midplane**
- Measure **local  $k_{\theta}$**  – small vertical jogs
- **Compare** measurement with **NOVA-K & M3D-K**

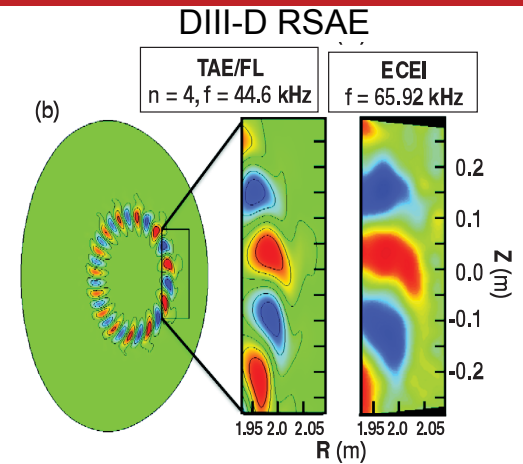

B. J. Tobias *et al* Phys. Rev. Lett. **106**, 075003 (2011)

NSTX NOVA-K eigenmode RSAE/TAE hybrid

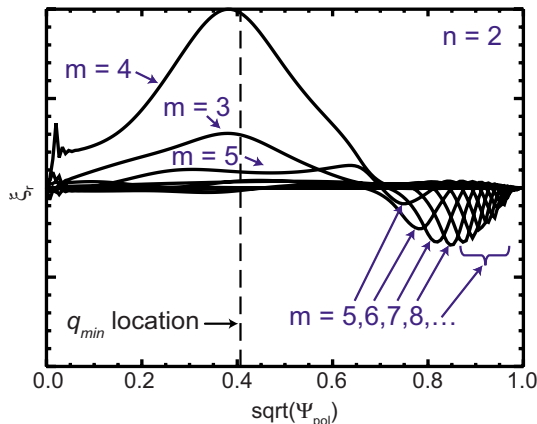

Reflectometer Position

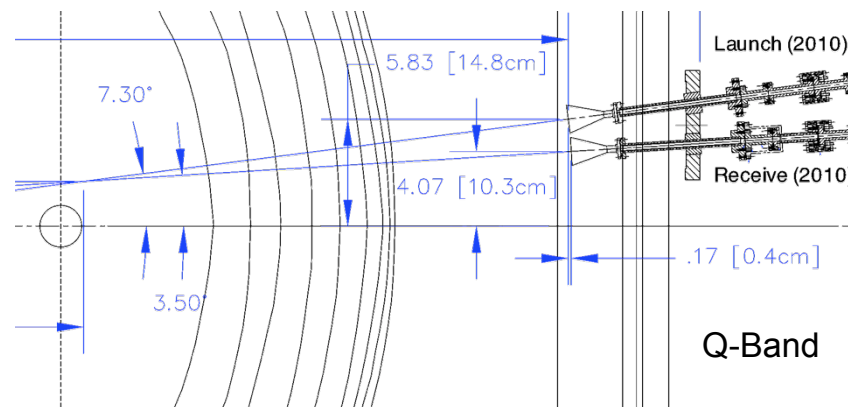

NSTX TAE structure

