

Physics & Technology Considerations for Electron Bernstein Wave (EBW) Heating and Current Drive on NSTX

D.A. Rasmussen, G.L. Bell, T.S. Bigelow, M.D. Carter, D.W. Swain,
J.B. Wilgen, ORNL, G. Taylor, P.C. Efthimion, J.R. Wilson, PPPL,
R.I. Pinsky General Atomics, R. Temkin, A.K. Ram, A. Bers, MIT
PSFC, R.W. Harvey, CompX.

Eighth International Spherical Torus Workshop

**Princeton Plasma Physics Laboratory
Nov 18-20, 2002**

Physics and Technology Considerations for Electron Bernstein Wave (EBW) Heating and Current Drive on NSTX*

D.A. Rasmussen, G.L. Bell, T.S. Bigelow, M.D. Carter, D.W. Swain, J.B. Wilgen, *ORNL*, G. Taylor, P.C. Efthimion, J.R. Wilson *Princeton U*, R.I. Pinsker *General Atomics*, R. Temkin, A.K. Ram, A. Bers, *MIT PSFC*, R.W. Harvey, *CompX*.

The in-plasma mode conversion (MC) of electron cyclotron (EC) waves to electron Bernstein waves (EBW), offers the possibility of greatly extending the useful density range over which high frequency ECH type heating techniques and capabilities can be utilized. Thus, EBW would enhance high beta operation in NSTX. The localization of power can enable localized current and flow drive. At low density, ECH can be used for noninductive startup assist. Recent studies of EBWs, via MC to X-mode electromagnetic radiation on the CDX-U and NSTX spherical torus (ST) plasmas, indicate that high mode conversion efficiency may be possible. New EBW emission antenna designs for X-mode and O-X-B and dedicated experiments are focused on achieving > 80% MC on NSTX during the next experimental campaign.

A multi-megawatt EBW heating and current drive (H&CD) system is under consideration for NSTX that could assist plasma startup, locally heat electrons, drive non-inductive current and suppress tearing modes or other MHD that limit high β operation. There are number of physics and technology considerations and tradeoffs that influence the design and application of EBW H&CD and startup assist on NSTX. EBWs have better radial access at fundamental resonance frequencies than at higher EBW harmonics, especially at high β . Also, since the fundamental X-B and O-X-B mode conversion layer is at densities that lie in the NSTX plasma scrape off, fundamental launch would potentially allow the use of a local limiter to control the density scale length at the mode conversion layer and hence maximize the tunneling and mode conversion efficiency. The emission measurements will be used to guide the launcher antenna/plasma interface and to decide whether the antenna should be designed to accommodate both X-B (normal incidence) and O-X-B (oblique incidence). Fundamental launch at 8, 12 or 15.3 GHz and second harmonic launch at 28 GHz are all under consideration. There are high power tubes available at both 8 and 28 GHz. The possibility exists to modify the 28 GHz tubes to operate at 15.3 GHz, but likely at somewhat reduced efficiency. Further tube development would be required for optimized high power tubes at either 12 or 15 GHz.

*Work Supported by U.S. DOE Contracts DE-AC05-00OR22725, DE-AC02-76CH03073, DE-FG02-91ER54109, and DE-FG02-99ER54521

EBW heating, CD and NTM stabilization roles



- Core Heating
- ECH or EBW Startup
- EBW CD ~ 400 kA with ~ 5MW
- NTM Stabilization at $\beta \sim 40\% \sim 5\text{MW} ?$

Requires efficient coupling, high power localization, efficient CD

EBW frequency choice for heating, CD and NTM stabilization involves a complicated set of tradeoffs



- **Coupling (X-mode, O-X-B, density scale lengths, limiters, fluctuations, profile evolution)**
- **Resonant location (center, profile, NTM, edge, harmonics)**
- **Power localization (launch aperture, acceptance angle)**
- **Critical density (ECH startup, EBW coupling)**
- **CD target density ($>$ critical density, $< 4 \times 10^{13} \text{ cm}^{-3}$)**
- **High β effects (Shafranov shift, B field scale lengths)**
- **Source power (MW/ unit)**
- **Nonlinear effects at edge (parametric, ponderomotive)**

EBW heating, CD and NTM stabilization target plasma

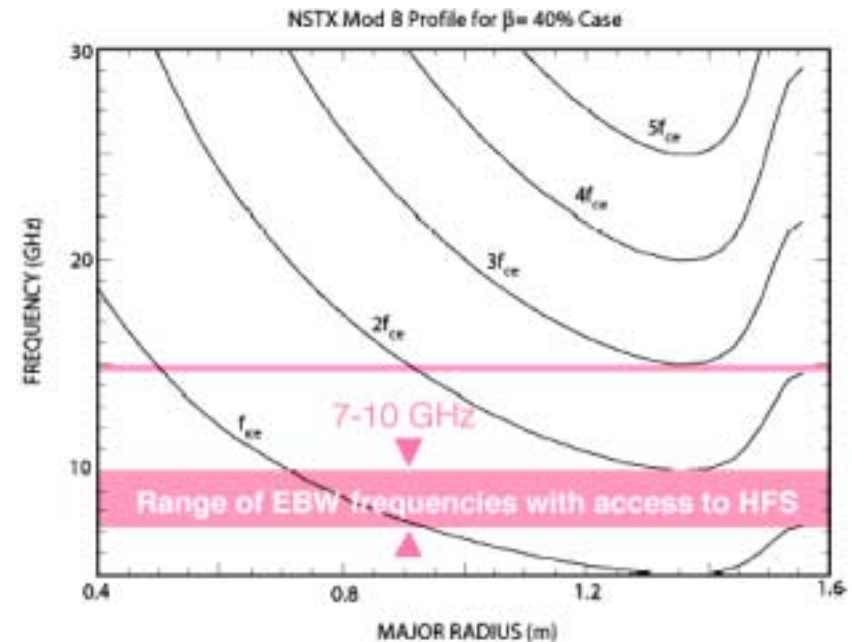
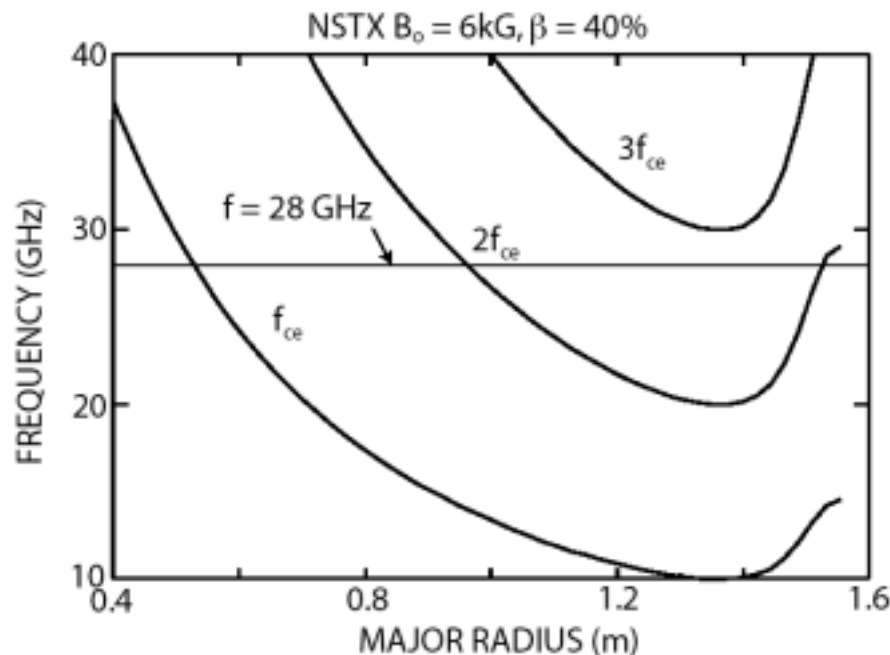

Modeling 12 GHz, 1MW for $\beta \sim 12\%$ NSTX gives dimensionless EBWCD efficiency $\sim 0.5[0.08 \text{ A/W}, T_{eo} = 1 \text{ keV}, n_{eo} = 2 \times 10^{19} \text{ m}^{-3}]$

EBW mode conversion region

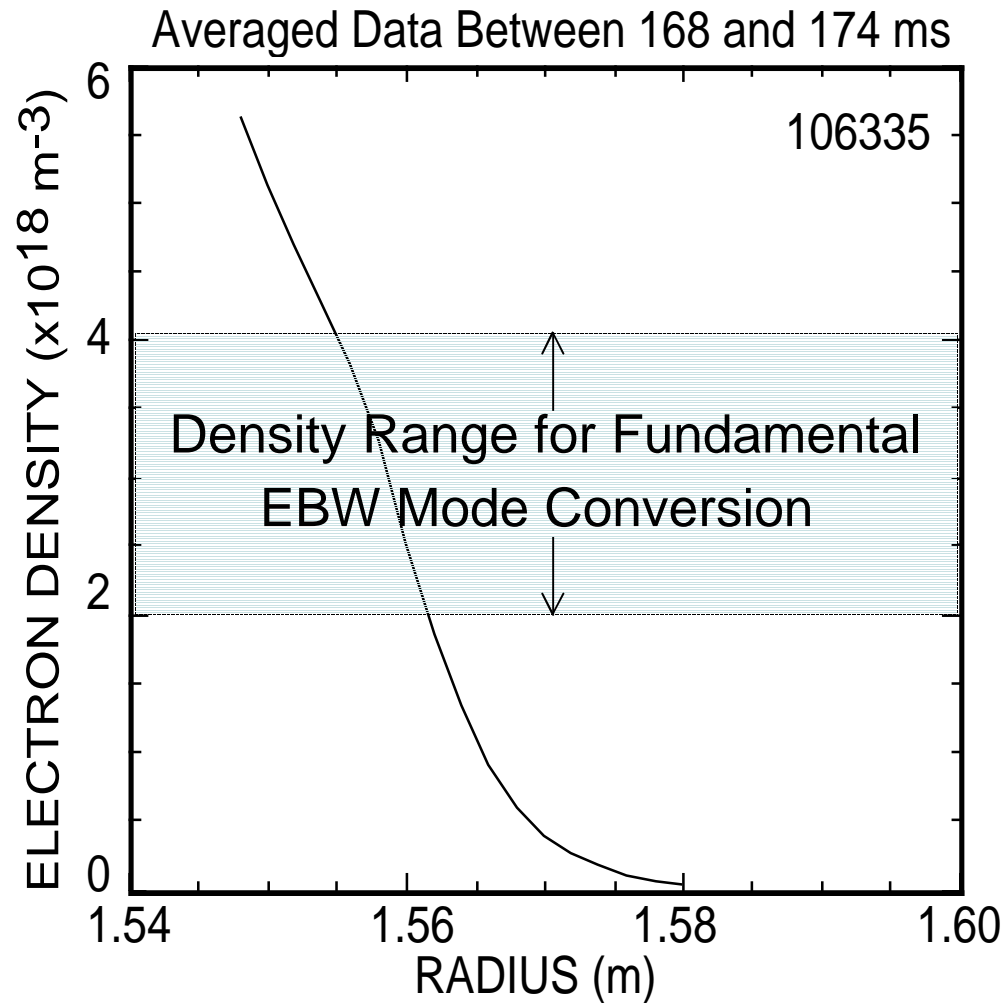

X-EBW

Transmission angle is a strong function of density gradient for $B_{rf} \parallel B_0$ incidence

n_p is the index of refraction in the perpendicular, but not radial direction

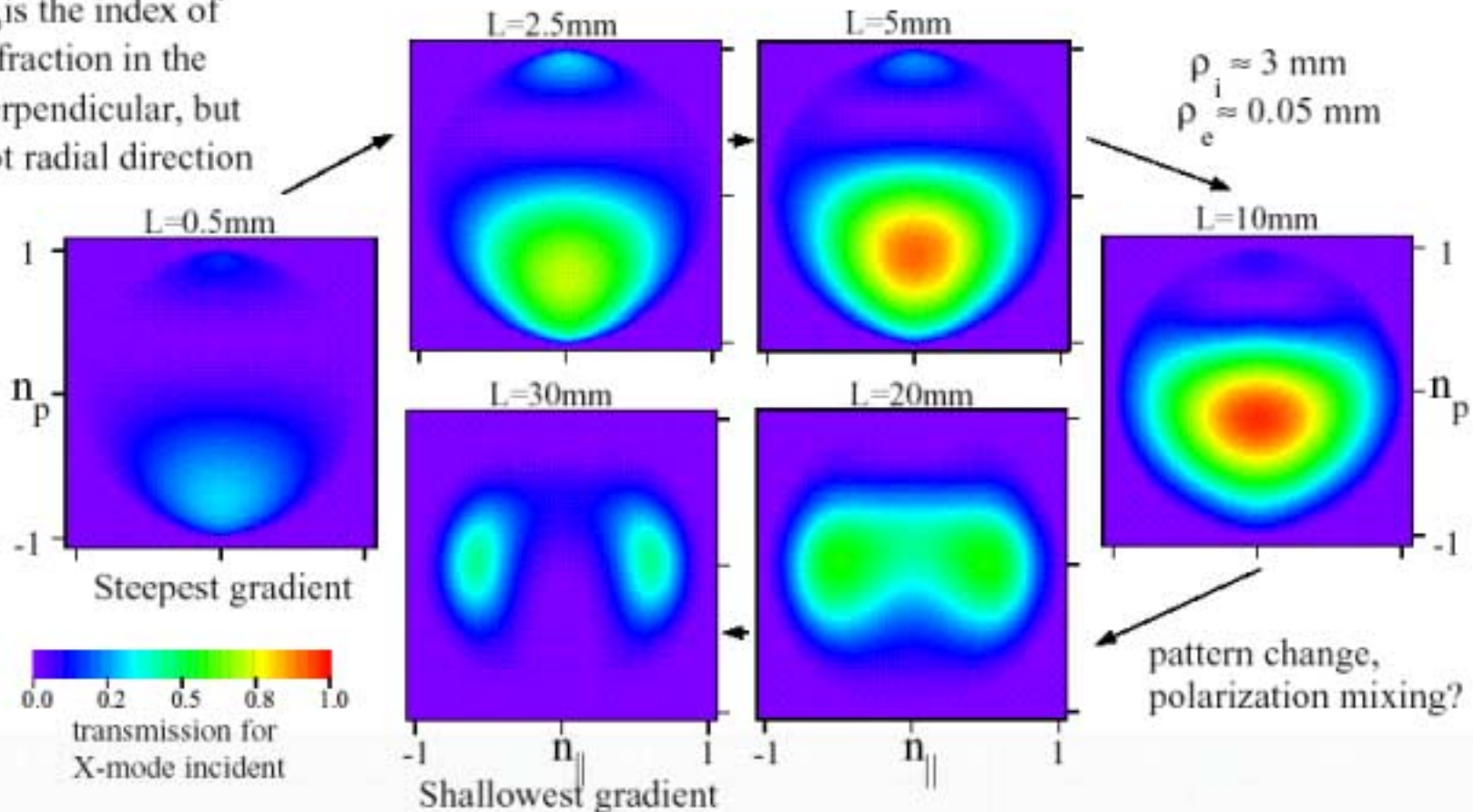

O-X-EBW

Optimum transmission angle depends weakly on density gradient for $B_{rf} \perp B_0$

n_p is the index of refraction in the perpendicular, but not radial direction

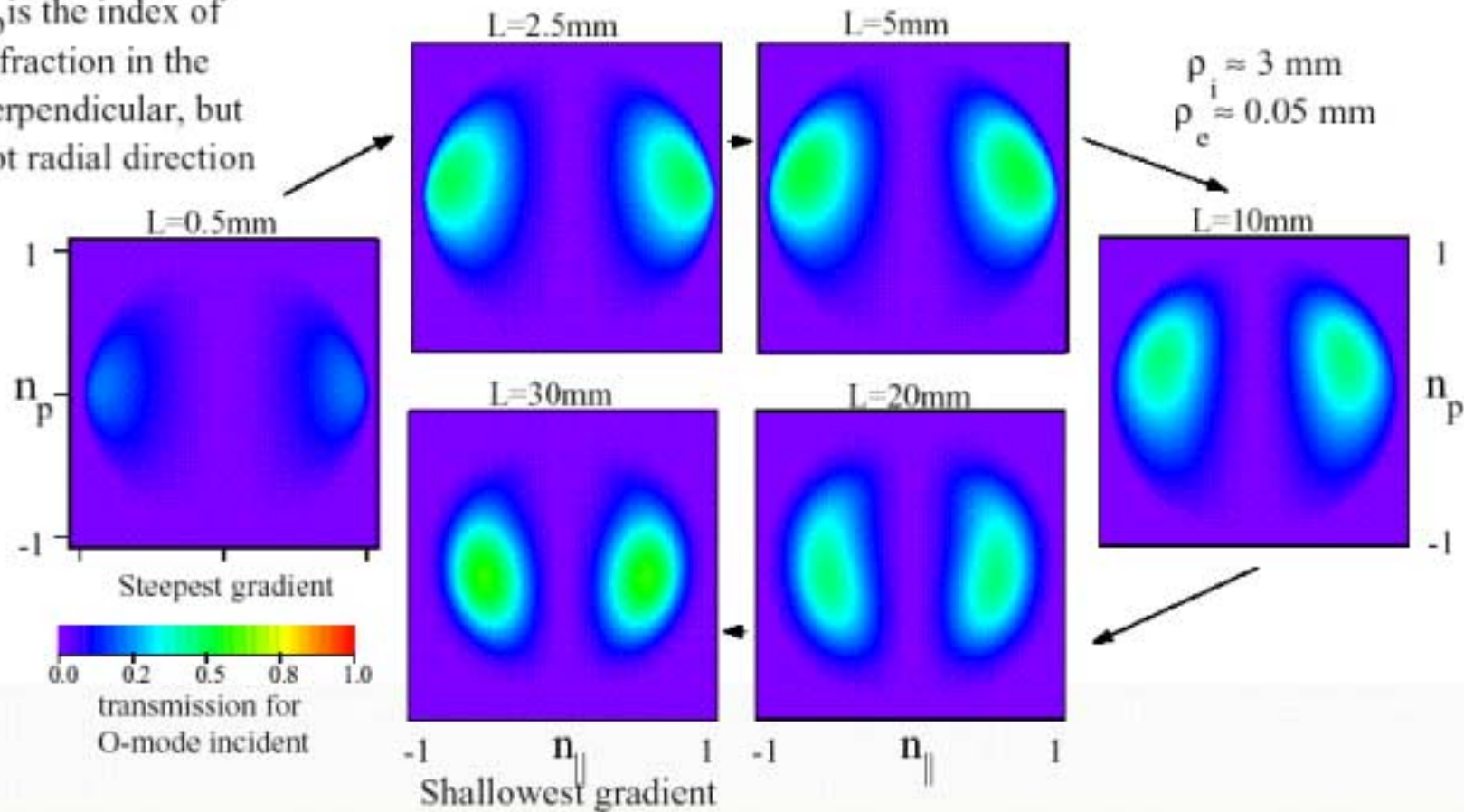

EBW emission, ST physics and high power tube technology impact the design



EBW emission measurements:

- Can indicate viability of EBW heating and current drive
- Guide the launcher antenna/plasma interface
- Help decide whether the antenna launch is X-B, O-X-B or both.

EBW “role” & coupling efficiency guide choice of launch frequency:

- Fundamental launch at 8, 12 or 15.3 GHz
- Second harmonic launch at 28 GHz

High power tubes:

- Available at both 8 and 28 GHz.
- Possibility exists to modify 28 GHz tubes to 15.3 GHz
- Tube development required for optimized high power tubes at ~ 12-15 GHz.

X-EBW quad-ridged antennas

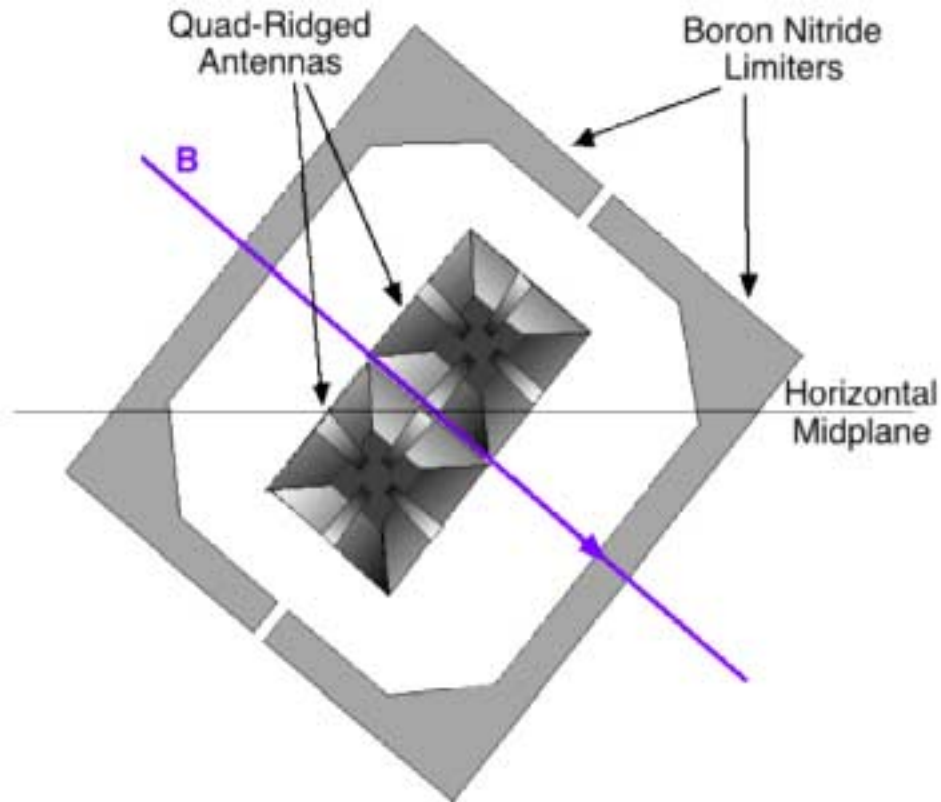

- Two radially movable boron nitride limiters
- Integrated with O-Mode reflectometer to measure local L_n
- local gas inlet valve to enable local density control

O-X-EBW boron nitride step antenna

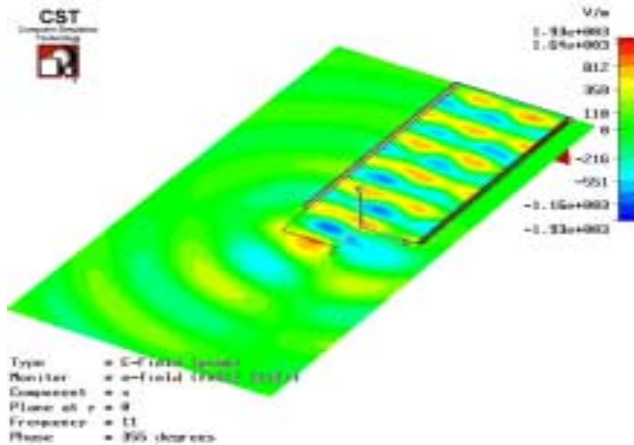
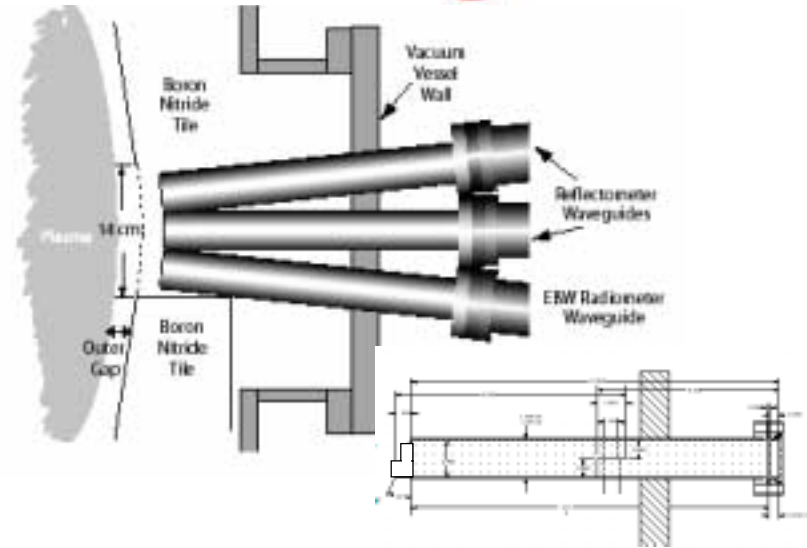

EBW frequency tradeoffs

H&CD, plasma startup, local heating, NTM suppression



Qualitative comments:

Frequency/ harmonic #	Resonant field (T)	Critical density $\times 10^{12} \text{ cm}^{-3}$	Scale length (mm) Coupling X O-X-B	Sources (MW)	Deposition spot size	Potential for driving edge parametric instabilities	Heating, CD, or NTM
28 GHz/fund	1	9.2	~ 1 ~10	0.3	++	1	H, CD?
2nd	0.5						H, NTM
3rd	0.33						NTM
18 GHz/fund.	0.64	3.8	~1.5 ~15	0.015	+	2 - 8 X	H, CD
2nd	0.32						NTM
15.3 GHz/fund	0.546	2.7	~ 2 ~20	0.2 Modified 28 GHz	+	4 - 16 X	H, CD, NTM
2nd	0.27						H, NTM
12 GHz/fund	0.43	1.3	~2.5 ~25	??	+	6 - 24 X	H, CD, NTM
2nd	0.21						?
8 GHz	0.29	0.95	~ 3 ~30	0.5	-	8 - 32 X	NTM
2nd	0.14						?

Thales 8 GHz 1 MW Gyrotron



Cavity Oscillation Mode	TE511
Nominal Output Frequency	8 GHz
Frequency Stability	+/- 1 MHz
Output Power (TE01)	1.1 MW
Peak Power @ VSWR = 4:1	700 kW
Frequency Pulling @VSWR=4:1	+/-2 MHz
Beam Voltage (typ)	84 kV
Beam Current (typ)	27 A
Efficiency	<= 46 %
Gun-anode Voltage (typ)	51 kV

The RF output is through a single disk, alumina (Al_2O_3) window, edge cooled by water flow.

Personal comment:
Basis for 1 MW 15 GHz design

28/15.3 GHz hardware available



- Utilize existing hardware to make experiments affordable
- Four 28 GHz, 200 kW, gyrotrons available at ORNL
- May be possible to retune and operate at 15.3 GHz
- Pulsed or cw tubes can be refurbished and generate 200-350 kW each (0.8-1.4 MW from 4 tubes)
- Four sockets and HV modulator/regulator are available at ORNL
- Utilize installed PPPL “NBI” power supply available at D-site (-90 kV at 40 A) or DNB supply (-90 kV, 30A)
- ATF beam launcher assembly

28 GHz to 15.3 GHz conversion



15.3 GHz TE01 mode:

Cathode Voltage = 80 kV

Mode Anode Voltage = 67 kV

Cathode to mod anode voltage = 13 kV

Cavity magnetic field = 0.60 T

Cathode magnetic field = 0.062 T

Beam magnetic compression = 9.7

Beam alpha (velocity ratio, $v_{\perp} / v_{\parallel}$) ~2.0

Beam size at cavity = 0.13 inch

Magnetic field profile optimization required





Proposed design for 1 MW 15 GHz

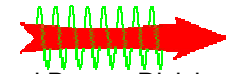

Waves and Beams Division

• Mode	TE ₀₂	• Perp. velocity spread	10 %
• Frequency	15 GHz	• Normalized cavity length L/l	4.4
• Magnetic field	0.58 T	• Cavity length	9.2 cm
• Beam current	25 A	• m parameter	8.15
• Beam voltage	70 kV	• Cavity radius R _c	2.233 cm
• Anode voltage	50 kV	• Limiting current	90 A
• Body voltage	20 kV	• Normalized detuning D	0.67
• Beam radius at cavity	1.45 cm	• Diffraction Q factor	360
• Beam pitch factor a	1.5	• Efficiency w/o depressed collector	47 %
• Voltage depression		• Efficiency w depressed collector	65 %
in cavity	2.5 kV	• Power	820 kW
• Cathode radius	4.5 cm	• Cavity wall loading	0.2 kW/cm ²

Personal comments:

MIT design; CPI engineering and fabrication. Guess; 1st tube ~ \$1M 2nd tube ~ \$.5M
Depressed collector likely not advantageous with PPPL power supplies
Thales would likely also bid with their own ~ 1 MW 15 GHz design



Self-consistent gyrotron design code

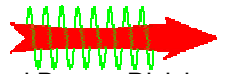

Waves and Beams Division

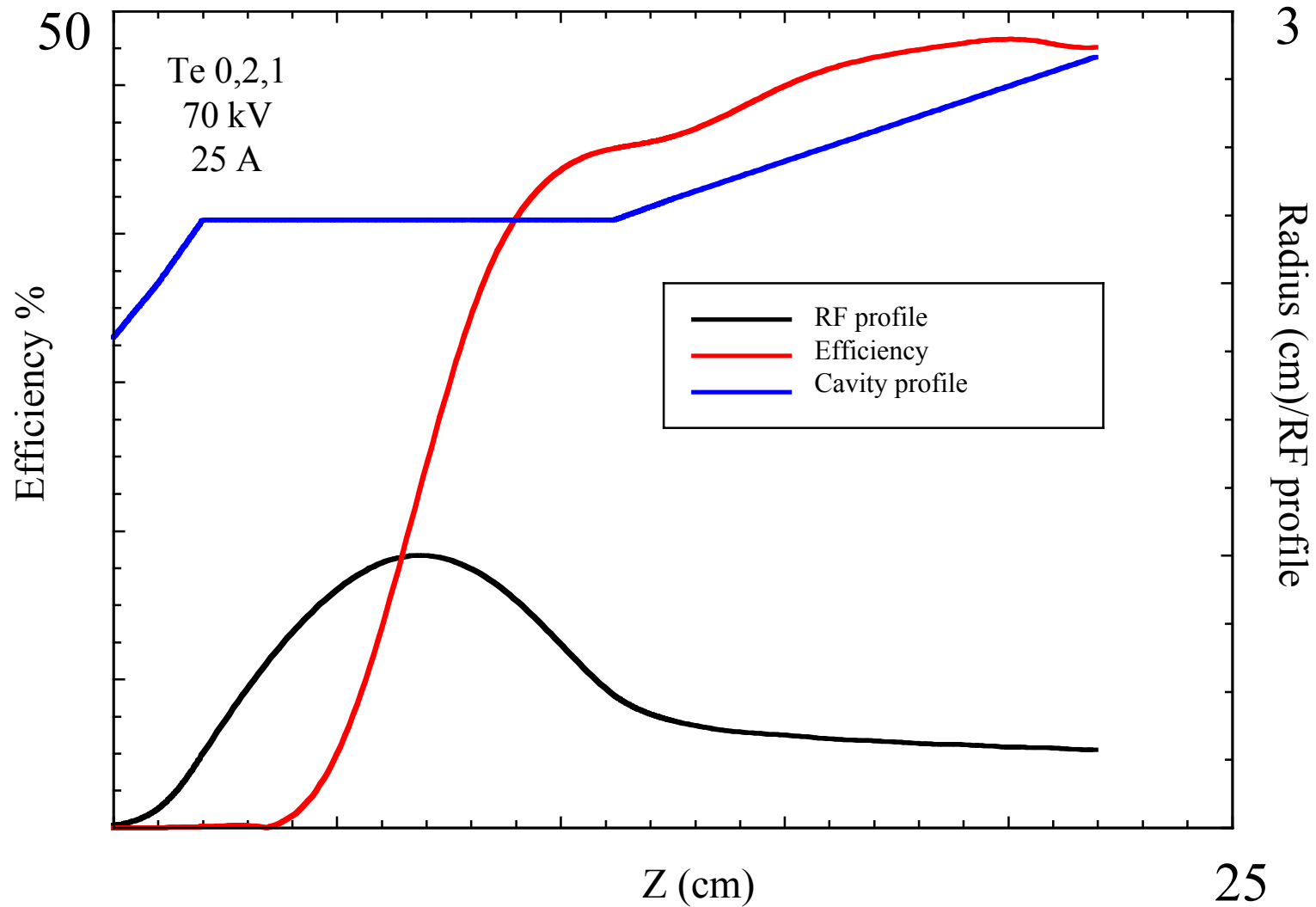

High power launcher requirements



- **For EBW and current drive schemes, high beam quality and focusing is required**
- **Some beam steerability desired**
 - Focusing mirrors close to plasma or
 - Phased array (4-8 waveguides)
- **Polarization control can be provided by external waveguide or by mirror grooves**
- **Three options under consideration**

Three possible launcher schemes



External mirror

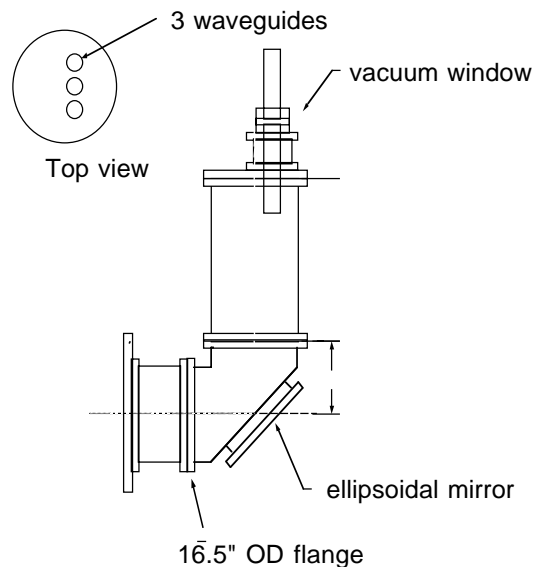

**Multiple
waveguide feeds**

Internal mirror

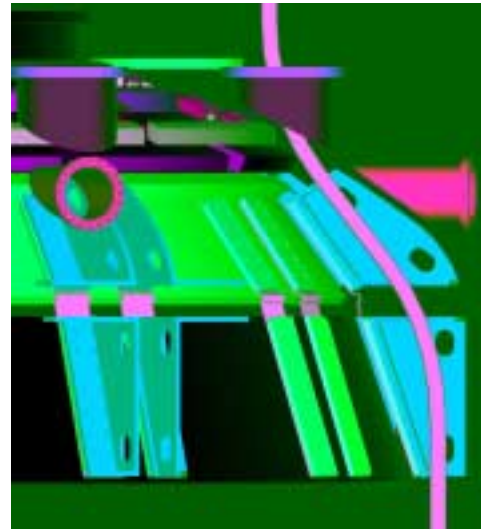

**Curved waveguide
through top port**

Waveguide grill

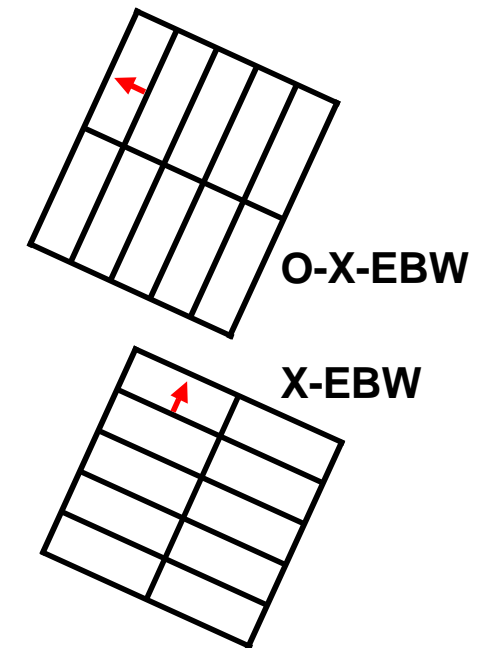

8-10 elements

Multiple gyrotron outside-mirror launcher configuration

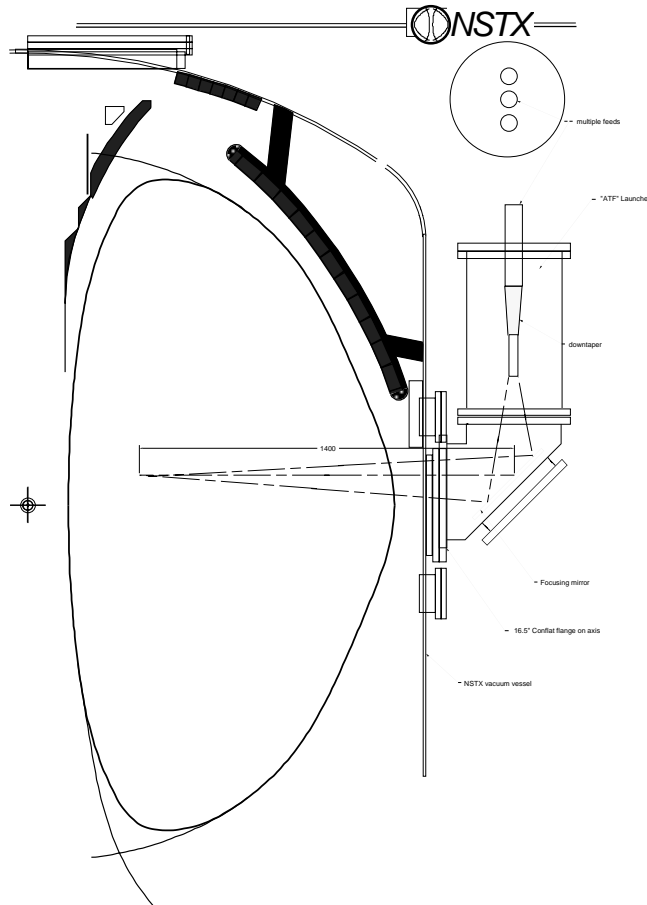

- Utilize existing launcher
- Need large midplane port
- Narrow focused beam
- Adjustable pointing angle
- Less beam steering possible



ECH launcher from ATF

Top port launch option



- Use several available top ports
- Route curved corrugated waveguide to midplane behind stabilization plates
- Use inside focusing mirror for launch
- Advantages
 - Ports available
 - Better launch optics
- More difficult for installation & beam steering

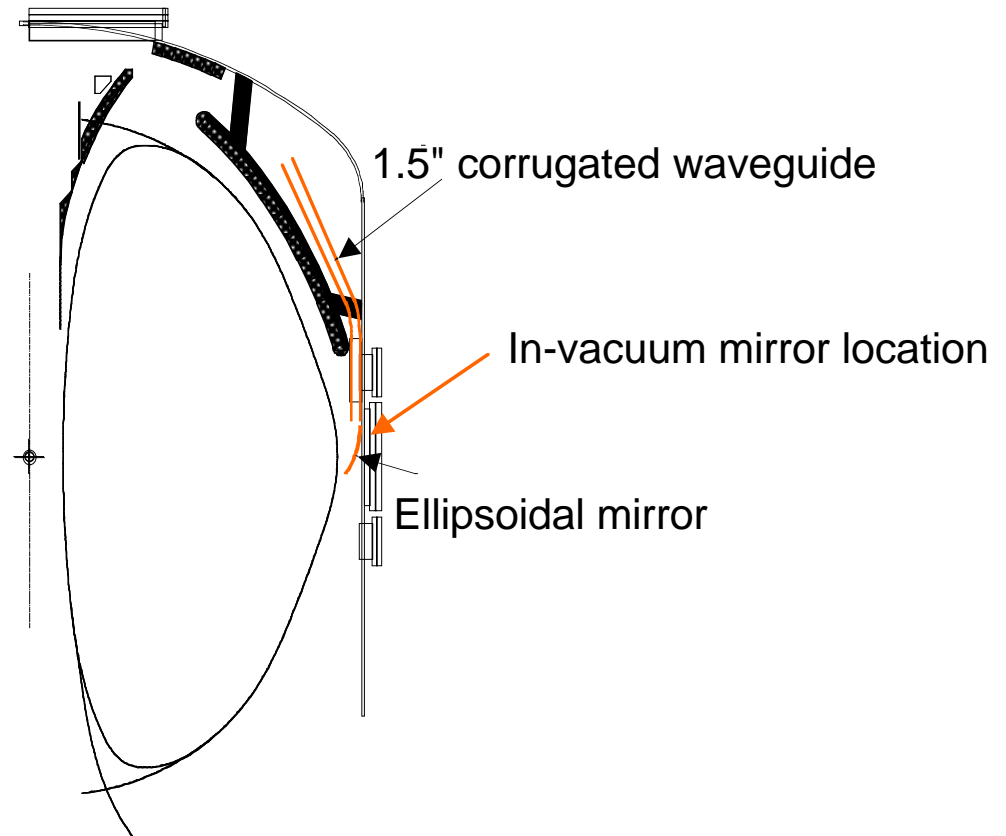

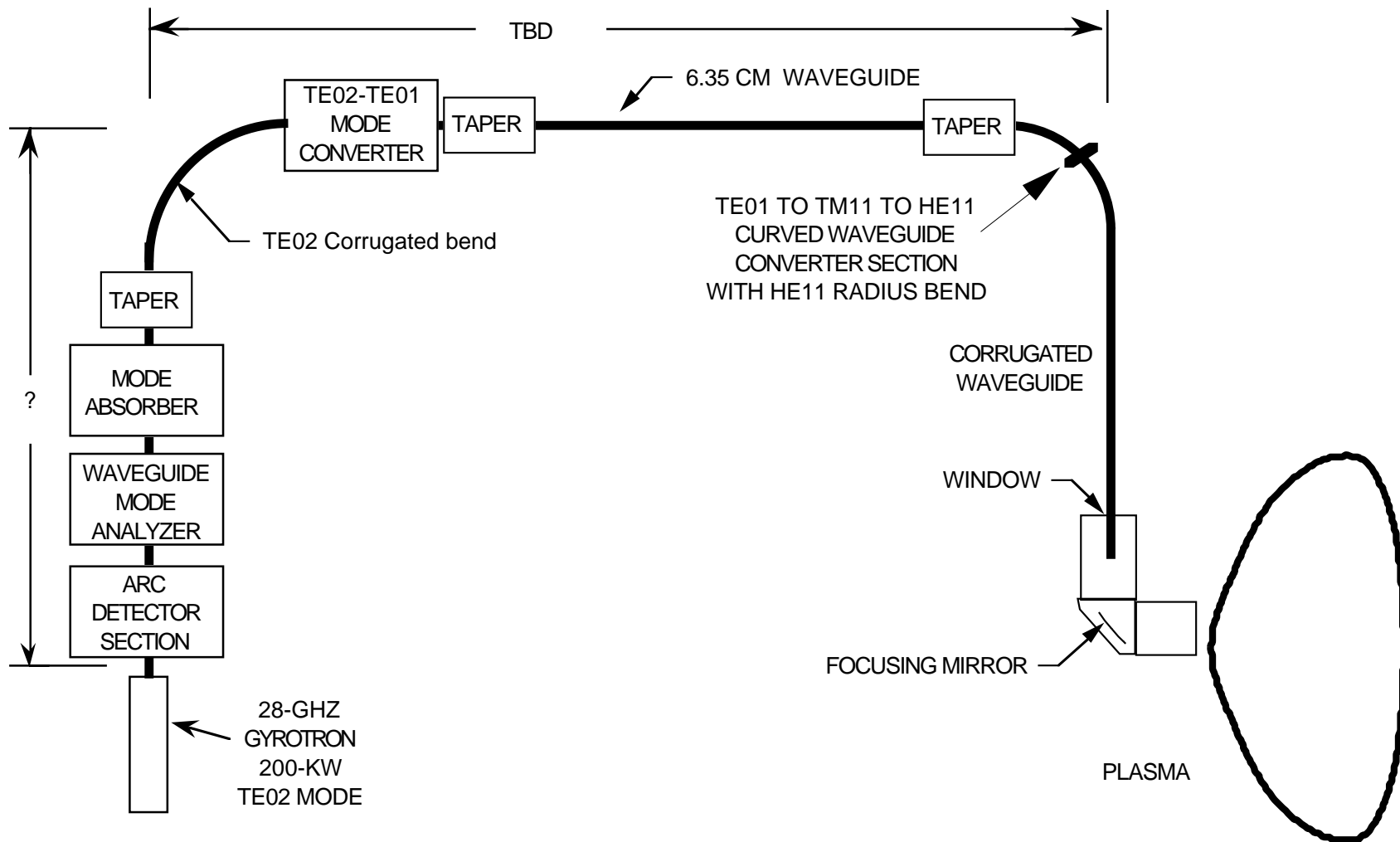

BLOCK DIAGRAM PROPOSED NSTX 28 GHZ ECH SYSTEM

Strawman Schedule & Goals



- Demonstrate >80% B-X conversion (local limiter, early 2003)
- Model EBW Heating & CD (early 2003)
- Demonstrate >80% B-X-O conversion (w or w/o local limiter, late 2003)
- Complete conceptual design for EBW heating and current drive system (early 2004)
 - Source frequency, f_{ce} or $2f_{ce}$?
 - Local limiter?
 - X-B or O-X-B
 - Power level? 1MW (2006), ~ 5MW (2008)
- Complete ~1MW installation (late 2006)
- Explore Core Heating (~ 1MW, 2006-7)
- Explore EBW Startup (~ 1MW, 2007)
- Complete ~ 5MW installation (2008)
- ~ 400 kA EBW sustained current (~ 5MW, late 2008)

Backup

GLOSI solves for mode converted wave fields in plasma edge

- For each poloidal and toroidal mode, generates a 2x2 surface impedance for tangential components of the RF fields at the plasma/vacuum interface

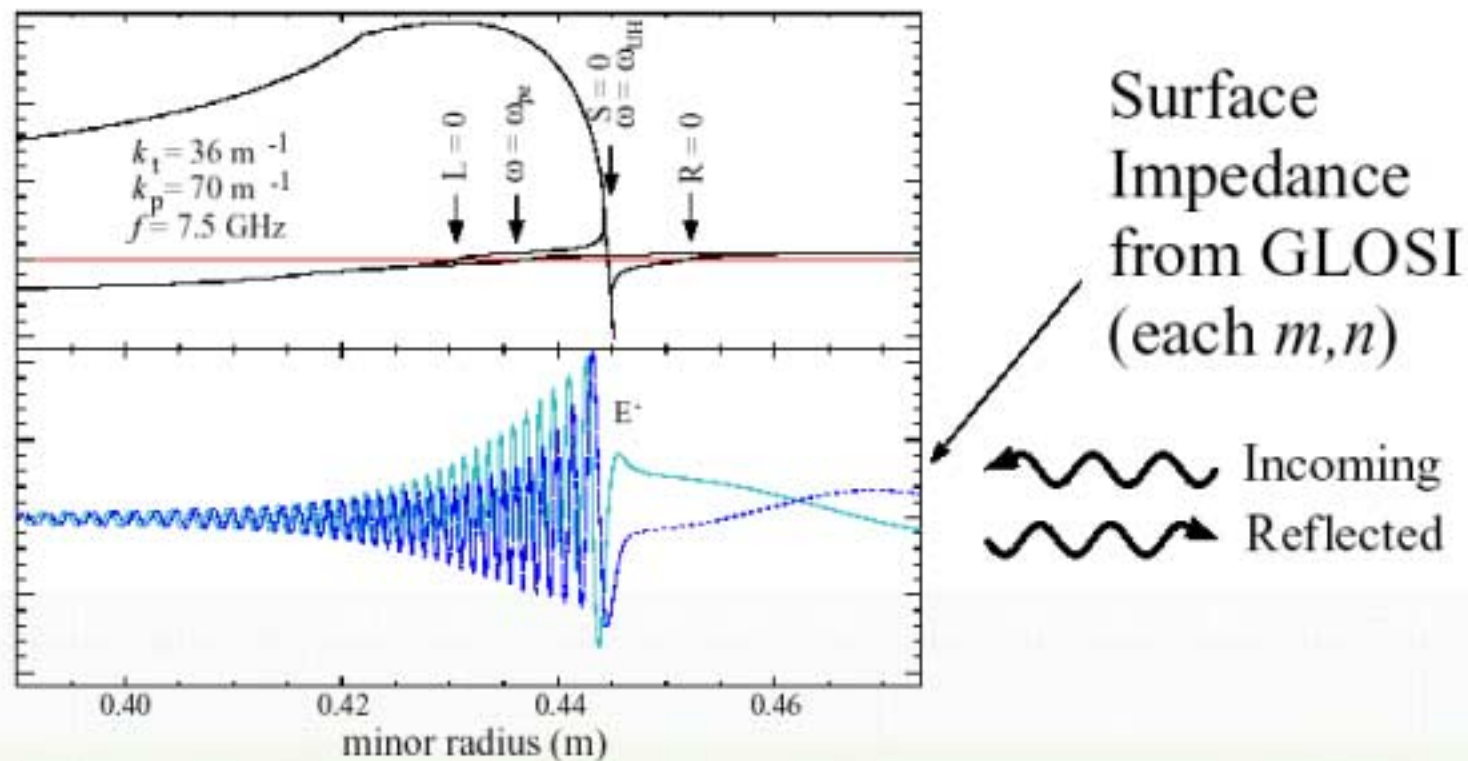

Systematic variation of density gradient near upper hybrid layer gives good idea about optimum angle for coupling

- Emission at same angles as absorption
- $T_e = T_i = 10 \text{ eV}$, $B = 0.13 \text{ T}$, 7 GHz

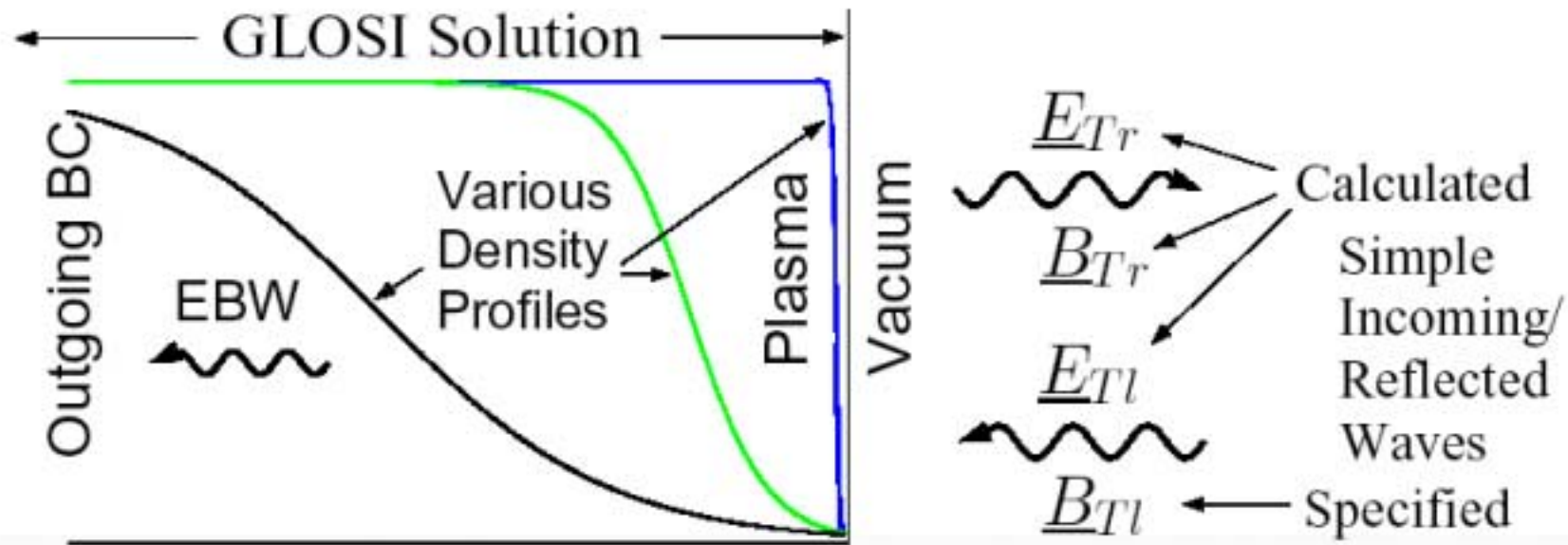

$$n_e = 1 \times 10^{18} \text{ m}^{-3} \left[1 - \tanh\left(\frac{x - x_r + 2L}{L}\right) \right]$$