

Recent Developments in High-Harmonic Fast Wave Physics in NSTX*

B.P. LeBlanc¹, R.E. Bell¹, P. Bonoli², R. Harvey³,
W.W. Heidbrink⁴, J.C. Hosea¹, S.M. Kaye¹, D. Liu⁵,
R. Maingi⁶, S.S. Medley¹, M. Ono¹, M. Podestà¹,
C.K. Phillips¹, P.M. Ryan⁶, A.L. Roquemore¹,
G. Taylor¹, J.R. Wilson¹

In collaboration with the NSTX Team

1) PPPL, Princeton, NJ 08543, USA

2) PSFC, -MIT, Cambridge, MA, 02139, USA

3) CompX, Del Mar, CA 92014, USA

4) University of California, Irvine, CA 92697, USA

5) Department of Physics, University of Wisconsin-Madison, WI 53706, USA

6) ORNL, Oak Ridge, TN 37831, USA

23rd IAEA Fusion Energy Conference

Daejeon, Republic of Korea, 11-17 October 2010

* Work supported by USA DoE contract DE-AC02-09CH11466

College W&M
Colorado Sch Mines
Columbia U
CompX
General Atomics
INL
Johns Hopkins U
LANL
LLNL
Lodestar
MIT
Nova Photonics
New York U
Old Dominion U
ORNL
PPPL
PSI
Princeton U
Purdue U
SNL
Think Tank, Inc.
UC Davis
UC Irvine
UCLA
UCSD
U Colorado
U Maryland
U Rochester
U Washington
U Wisconsin

Culham Sci Ctr
U St. Andrews
York U
Chubu U
Fukui U
Hiroshima U
Hyogo U
Kyoto U
Kyushu U
Kyushu Tokai U
NIFS
Niigata U
U Tokyo
JAEA
Hebrew U
Ioffe Inst
RRC Kurchatov Inst
TRINITI
KBSI
KAIST
POSTECH
ASIPP
ENEA, Frascati
CEA, Cadarache
IPP, Jülich
IPP, Garching
ASCR, Czech Rep
U Quebec

Introduction

- Goal of High-Harmonic Fast-Wave (HHFW) ion cyclotron range of frequency research on NSTX is to maximize power coupled to plasma:
- Understand and mitigate power loss outside last closed flux surface (LCFS):
 - Relevant to ITER
- NSTX capabilities:
 - Auxiliary heating system includes 7 MW NBI and 6 MW ICRF
 - A complete set of standard diagnostics, and in particular fast-ion diagnostics like fast-ion D-alpha FIDA [1]
- The physics basis of HHFW heating and a review of recent HHFW research are available elsewhere [2], [3]:
 - Typically more than 5 ion-cyclotron resonances present within the plasma in NSTX
- Competition between two dominant absorption mechanisms inside the LCFS:
 - Electron heating via Landau damping and transit-time magnetic pumping,
 - Wave-field acceleration of NBI generated fast ions

[1] M. PODESTA, et al., Rev. Sci. Instr., 78, 10E521 (2008)

[2] M. ONO, Physics of Plasmas, 2, (1995) 4075

[3] G. TAYLOR, et al., Physics of Plasmas, Vol. 17 (2010) 05611

HHFW Antenna Has Well Defined Spectrum Ideal for Controlling Deposition, CD Location & Direction

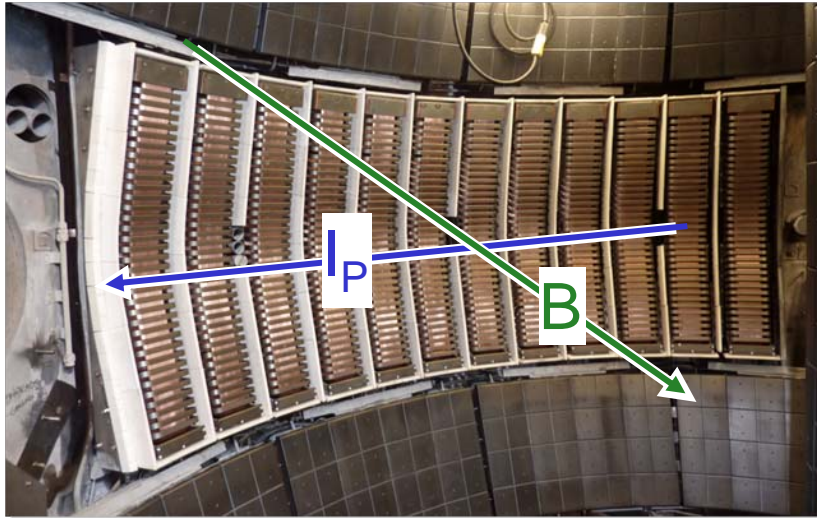

HHFW antenna extends toroidally 90

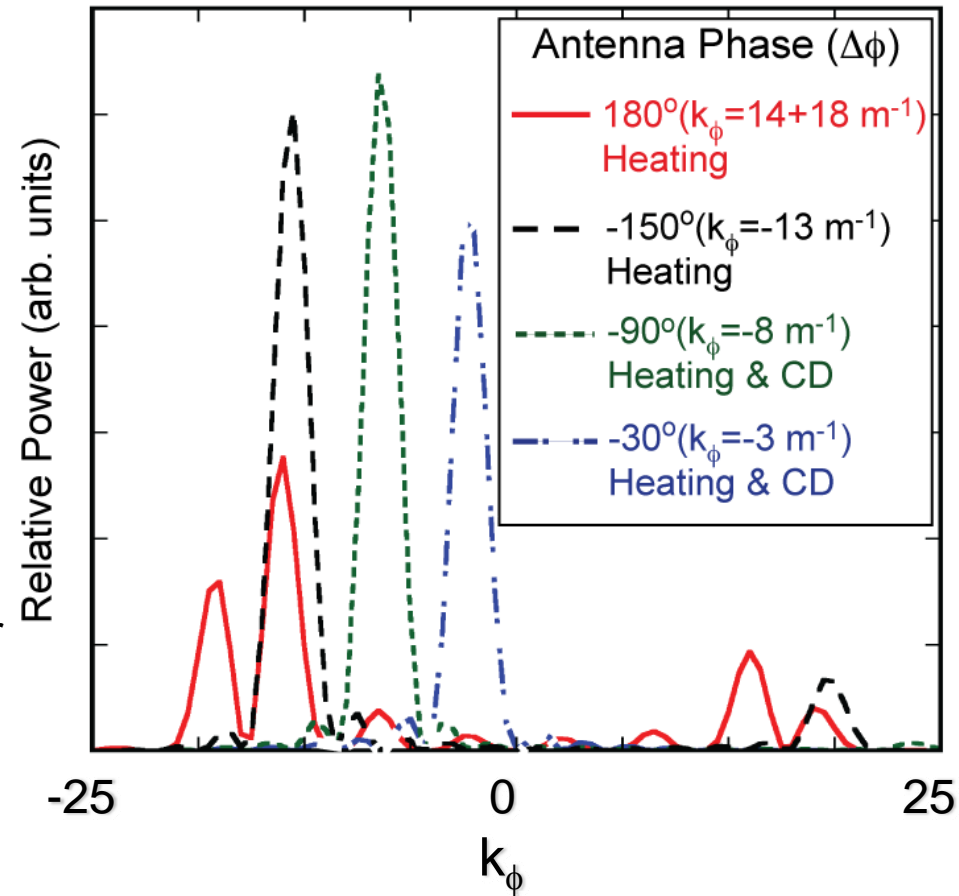
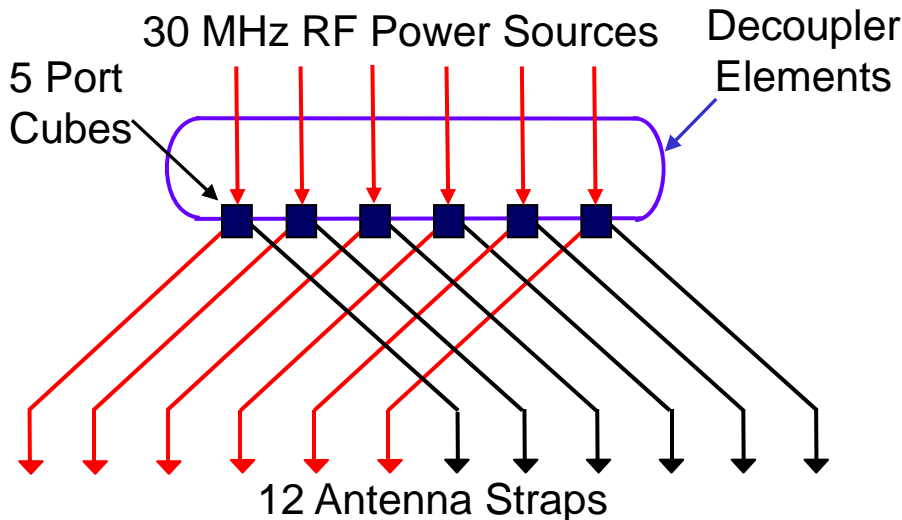

- Phase between adjacent straps ($\Delta\phi$) easily adjusted from 0° to 180°

Edge Power Absorption and Dispersion

- Propagation onset, power dispersion:
 - Radio–frequency (RF) evanescent wave exits antenna until reaching a region where the local electron density is at the critical level ("onset density") for fast-wave propagation perpendicular to the magnetic field.
 - Propagation onset typically occurs outside of the LCFS, resulting in excitation of surface waves [5]. Such losses can be reduced by having the “onset density” further away from the antenna.
- Edge power absorption:
 - Edge ion heating by parametric decay instability (PDI) is another phenomenon reducing the power reaching the plasma within the LCFS [7]

[4] J.R. WILSON *et al.*, Phys. Plasmas, 10, No. 5, (2003) 1733

[5] J.C. HOSEA, *et al.*, Phys. Plasmas 15 (2008) 056104

[6] D.M. MASTROVITO, *et al.*, Rev. Sci. Instrum. 74 (2003) 5090

[7] T.BIEWER, *et al.*, Phys. of Plasmas 12 (2005) 056108

Divertor Power Flux Increase during HHFW Heating

- Infrared measurements [6] indicate a significant amount of the antenna power redirected to divertor
- Heat flux reaching the divertor for two consecutive discharges, both with 2 MW NBI, but with the second having an additional 2.6 MW HHFW heating. In the vicinity of $R = 1\text{ m}$, the heat flux increases fivefold with RF power applied

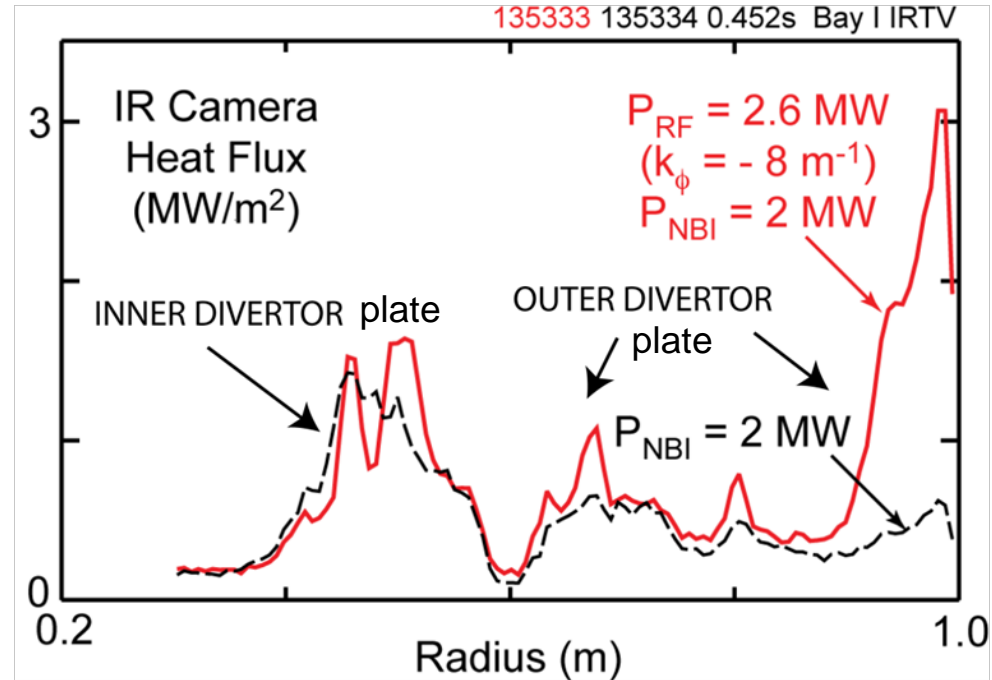

- Divertor heat flux vs. major radius (Preliminary calibration)
- Antenna set to $k_{//} = -8\text{ m}^{-1}$

[6] D.M. Mastrovito, et al., Rev. Sci. Instrum. 74 (2003) 5090

RF Wave Accelerate Fast Ions in L-mode Plasma

- Pulsed 1 MW NBI injection at 65 kV
- Long HHFW 1 MW pulse at $k_{//} = -8 \text{ m}^{-1}$
- HHFW power induces a cumulative tripling of neutron production, S_n

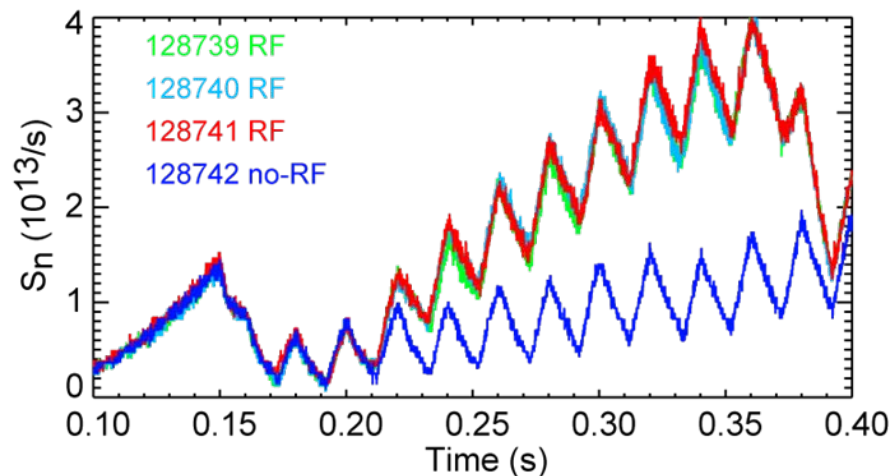
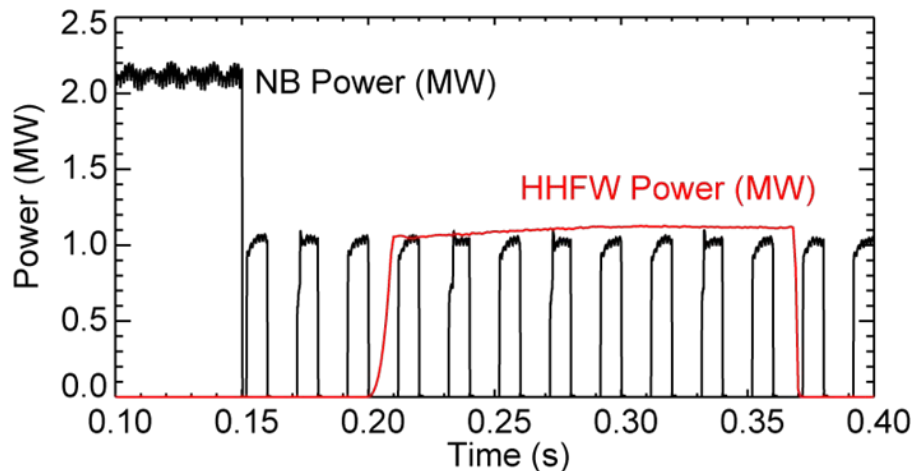

Measured Fast-ion Density Increase during HHFW Heating in L-mode Plasma

- Fast-ion D-alpha (FIDA) signal [10]
 - Signal integrated over 30keV-60keV energy range, is proportional to the density of these high-energy fast ions
- Near doubling and broadening of fast-ion density when HHFW is added to NBI [9]

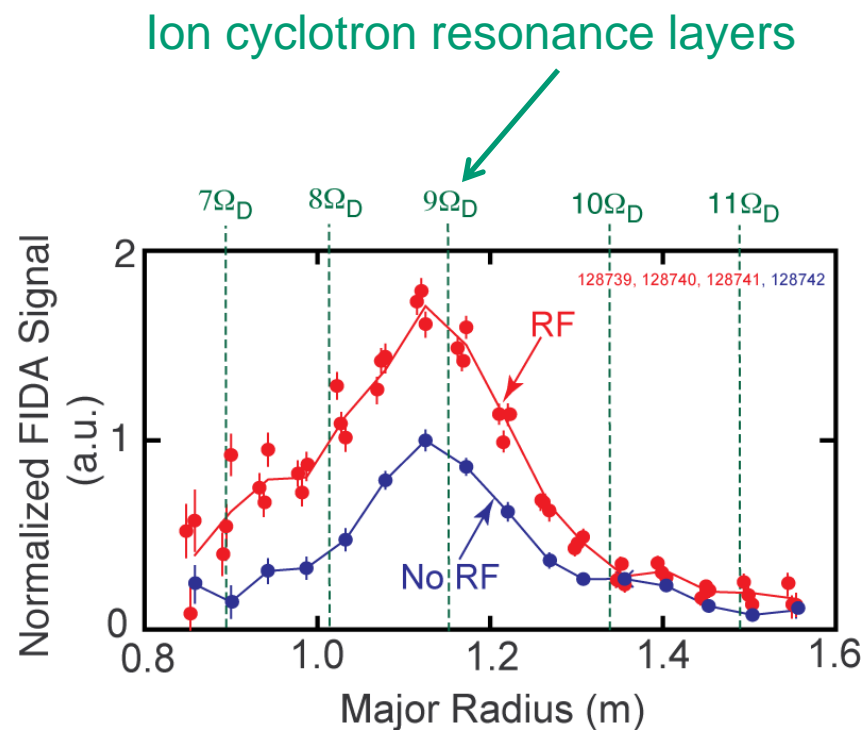

[9] D. LIU, et al. Plasma Physics and Controlled Fusion, Vol. 52 (2010) 025006

[10] M. PODESTA, et al., Radio Frequency Power in Plasmas, AIP Conf. Proc. 1187 (2009) 69-76

HHFW Heating of NBI-induced H-mode plasma

- In the past this task has proved challenging, with essentially no HHFW power reaching the plasma within the LCFS [11]
- Recently, a sizeable amount of power coupled to the enclosed plasma, resulting in a significant increase in the total stored energy and in the neutron rate.

[11] B.P. LEBLANC, *et al*, Radio Frequency Power in Plasmas, AIP Conf. Proc. 787 (2005) 86

Compare Two Matched ELM-free H-mode Discharges NBI+HHFW vs. NBI

- I_p : 0.9MA, TF: 0.55T
- NBI: 2MW, 90kV
- HHFW: 2MW, $k_{//}=13m^{-1}$
- Benign MHD activity in both plasmas
- MSE unavailable
- Times of interest (TOI) 0.248s and 0.315s

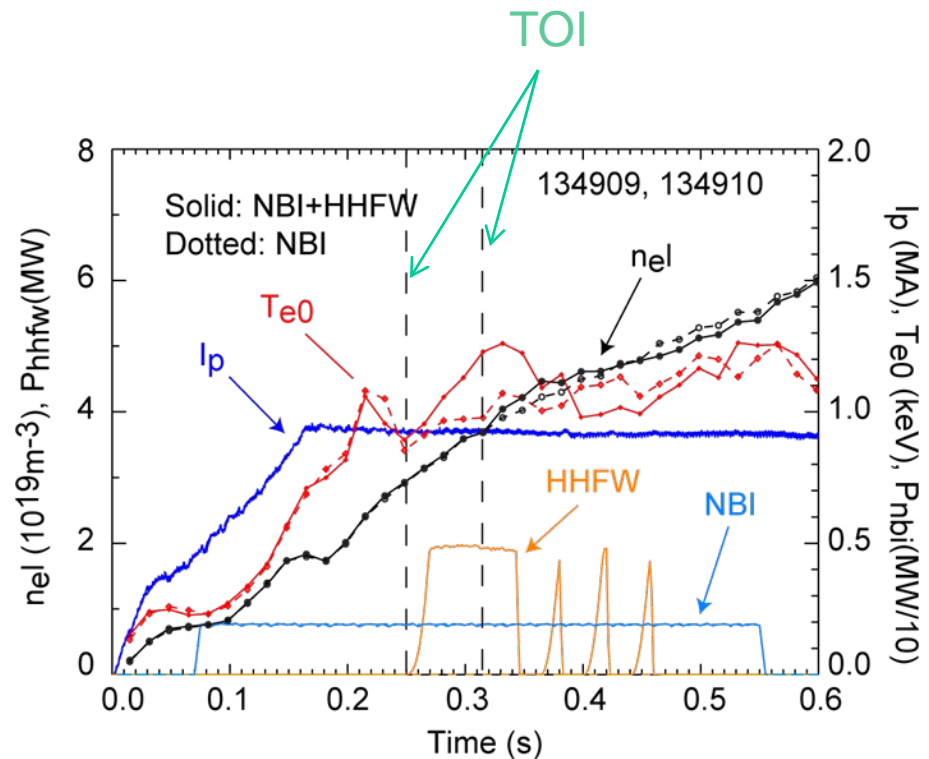

Broad T_e Profile Increase with HHFW Heating of NBI-induced H-mode Plasma

Prior to HHFW Heating

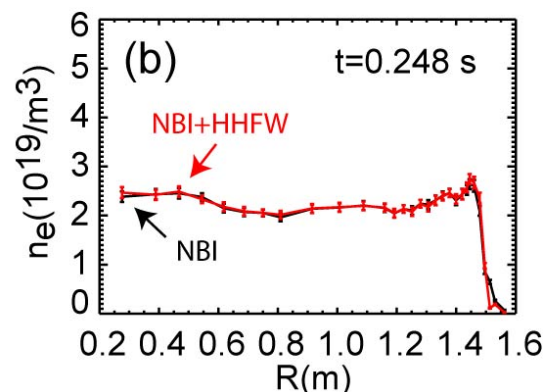
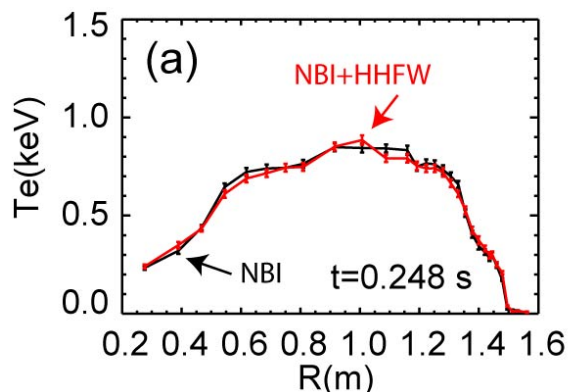

Thomson scattering profiles

During HHFW Heating

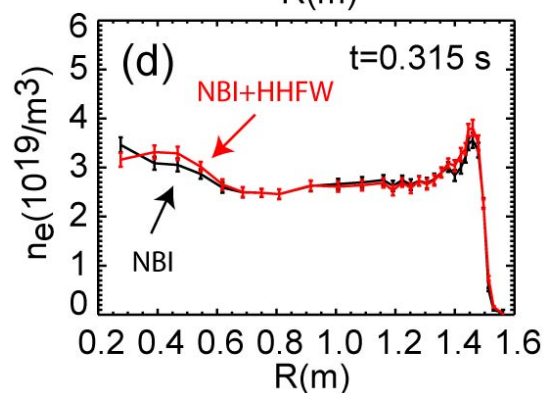
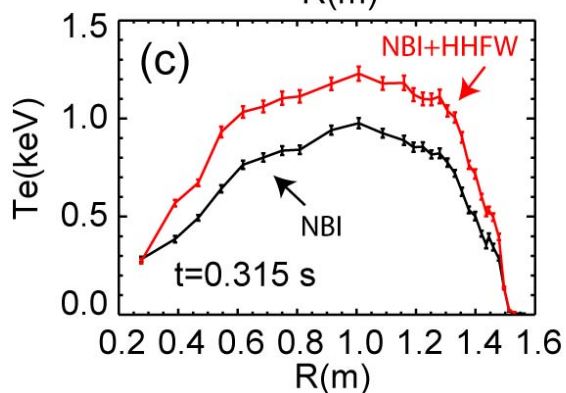

- Identical T_e and n_e H-mode profiles prior to HHFW power onset
- Broad T_e profile increase during HHFW heating, n_e profile remains unchanged. Plasma stayed in the H mode.

TRANSP Analyses of NBI+HHFW and NBI-only ELM-free H-mode Discharges

NBI+HHFW

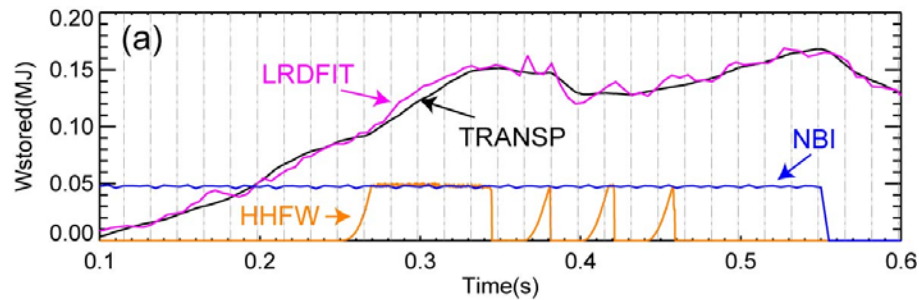

134909B06

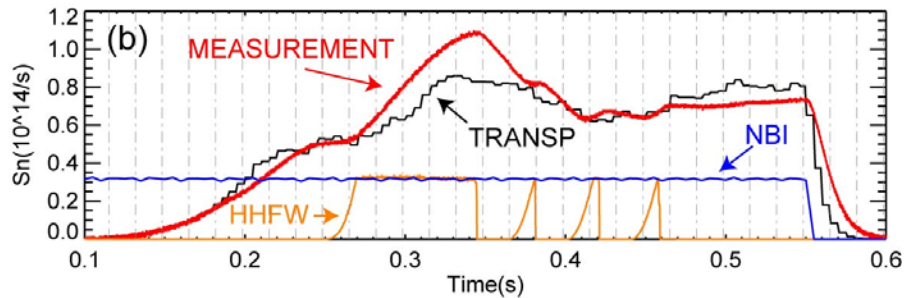

- Good match for stored energy, but underestimate neutron production

NBI

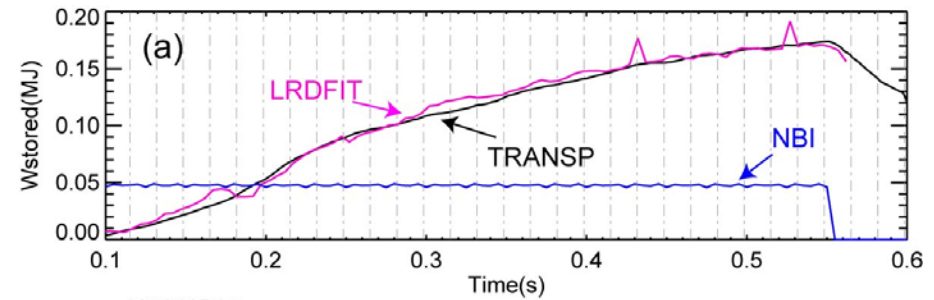

134910B04

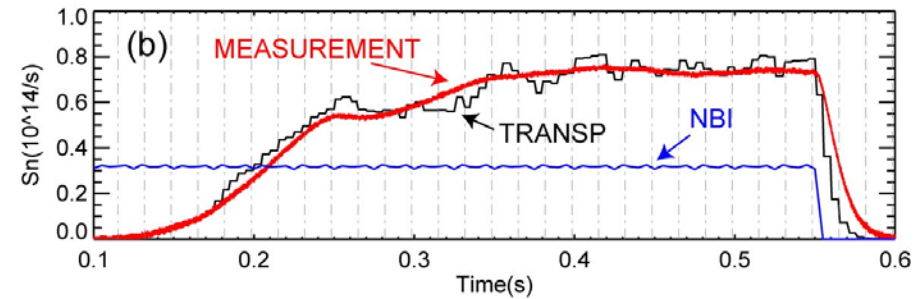

- Good match for stored energy and neutron production

Estimate HHFW Power Fraction Absorbed within LCFS Based on the Electron Stored Energy

- Three TRANSP calculations of the electron stored energy:
 - (1) Analysis based on the experimental data for combined NBI and HHFW heating
 - (2) Analysis based on the NBI-only experimental data
 - (3) A predictive TRANSP/TORIC calculation
 - Electron thermal diffusivity, χ_e , from the NBI-only reference discharge
 - Assume 100% of antenna power absorbed within LCFS
 - Predict T_e for the NBI+HHFW

Evolution of Electron Stored Energy Estimates

- W_{eX} is the electron stored energy obtained from the experimental NBI+HHFW TRANSP analysis
- W_{eR} corresponds to the reference NBI-only analysis
- W_{eP} corresponds to the predictive calculation mentioned in previous slide.

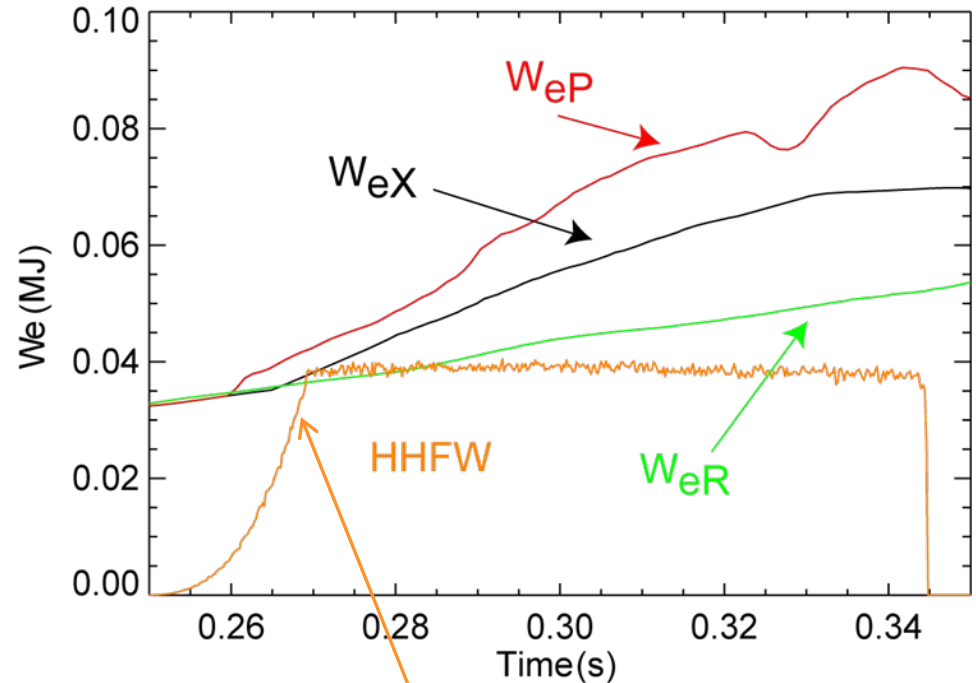

Unscaled HHFW power trace

Coupling to Enclosed Plasma Based on Electron Stored Energy

- Power coupled to the enclosed plasma
- $P_{eC} = f_C \times P_{eP}$, where the fraction, f_C , of the captured antenna defined as

$$f_C = (W_{eX} - W_{eR}) / (W_{eP} - W_{eR})$$

- $\langle f_C \rangle = 0.53 \pm 0.07$
- 1MW absorbed within LCFS
 - 0.7MW by electrons
 - 0.3MW by fast ions

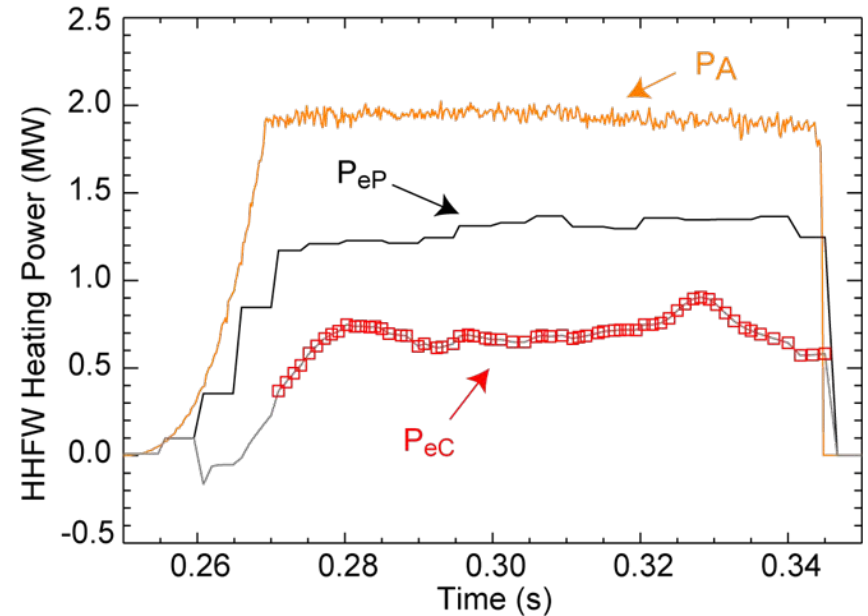

P_A : launched antenna power

P_{eP} : TORIC calculation of power to electrons assuming 100% capture
With LCFS

CQL3D to Estimate Effects of Wave Interaction with Fast Ions

- Currently TRANSP lacks the software to evolve self-consistently the fast-ion energy distribution under the influence of the wave field
- CQL3D is a relativistic collisional, quasi-linear 3D code which solves a bounce-averaged Fokker-Planck equation
- CQL3D can be used to compute the wave effects on the fast ions and neutron production
- Using input data from TRANSP at a particular time of interest, CQL3D is “run to equilibrium” in order to estimate the neutron rate
- CQL3D offers two calculation options:
 - A "no loss" option (NL), which assumes zero banana width orbits
 - A "simple-banana-loss" calculation (SBL)

CQL3D Predicts Significant Fast-ion Losses

Neutron Production (S_n)

- "no loss" (NL) exceeds S_n measurement
- "simple-banana-loss" (SBL) is at lower limit of measurement error range
 - For 1MW captured within LCFS, about 60% of the power to fast ions is lost compared to NL
- A first-order final-orbit width loss model will be implemented for CQL3D

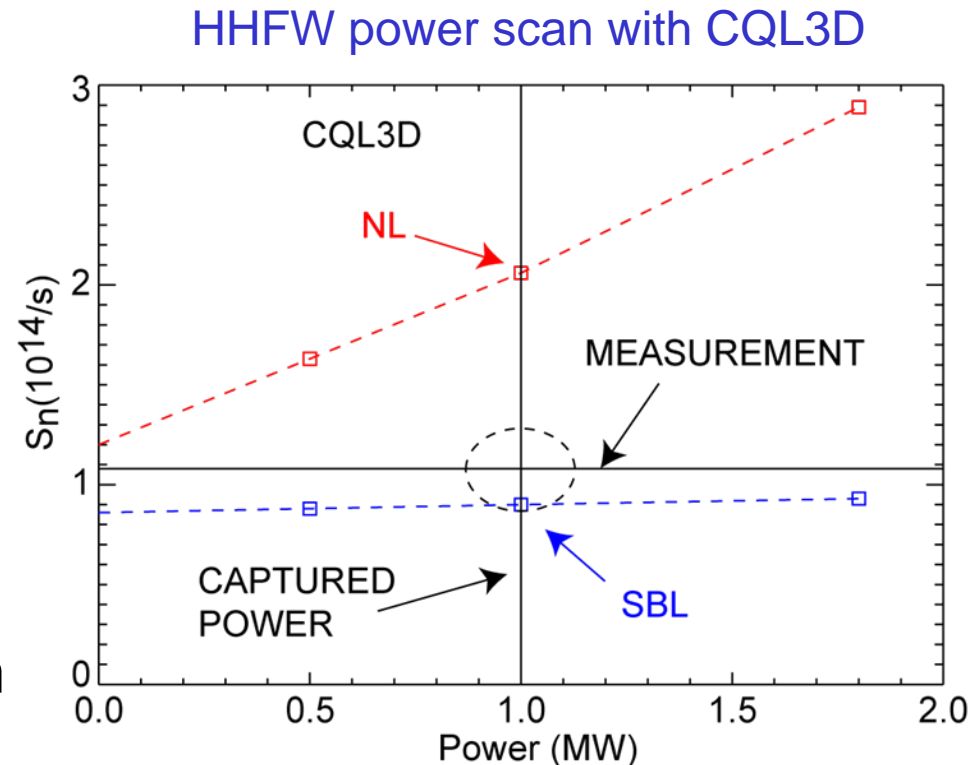

FIDA Measurements for NBI+HHFW vs. NBI

No Fast-ion density change observed with HHFW *in this case*

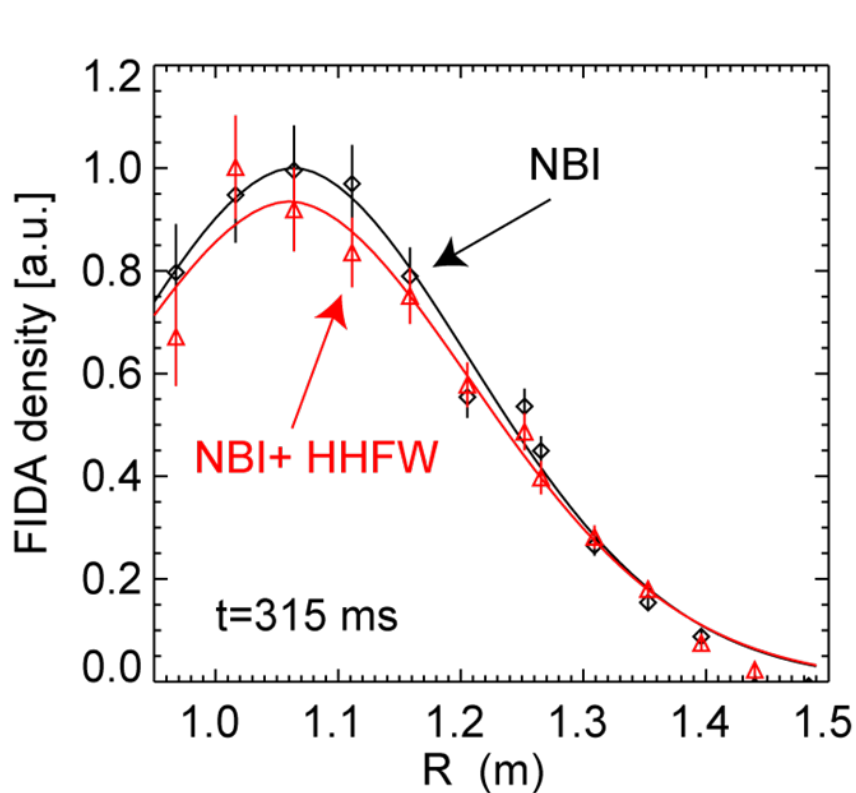

- FIDA density profiles at t=0.315 s for, red, plasma with NBI+HHFW heating and, black, reference NBI-only plasma

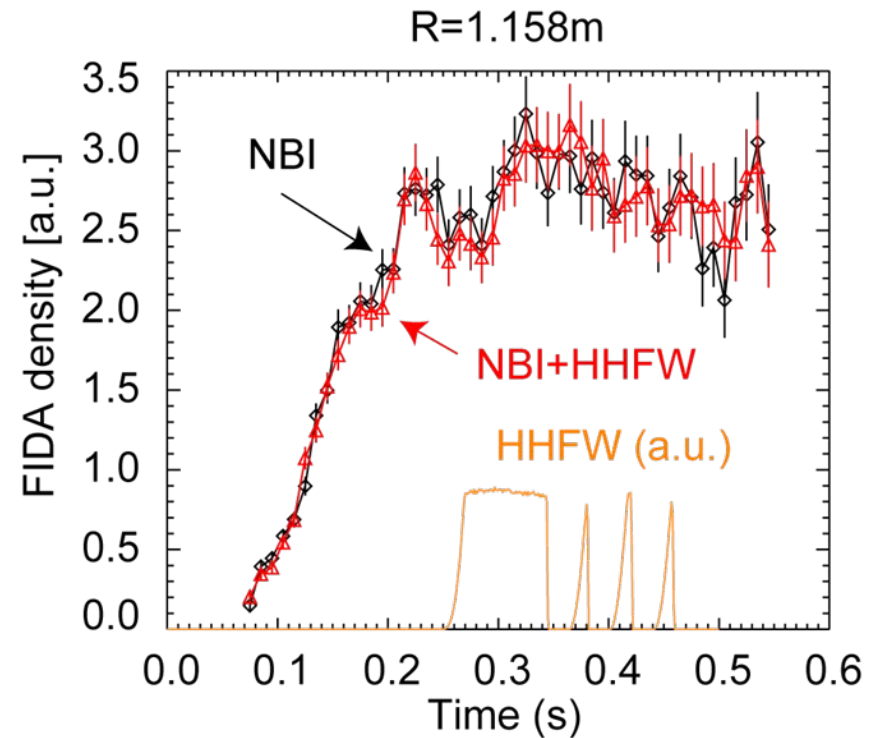

- Evolution at R=1.158m of FIDA density for, red, plasma with NBI+HHFW and, black, reference NBI-only plasma

TRANSP S_n Estimate Depends on Equilibrium

- Equilibrium solvers LRDFIT and EFIT predict S_n within experimental bar
- EFIT's current profile is more peaked
 - More current in the core region is conducive to better fast-ion confinement and higher neutron production.
- Measurement of q profile (MSE) needed for future experiments

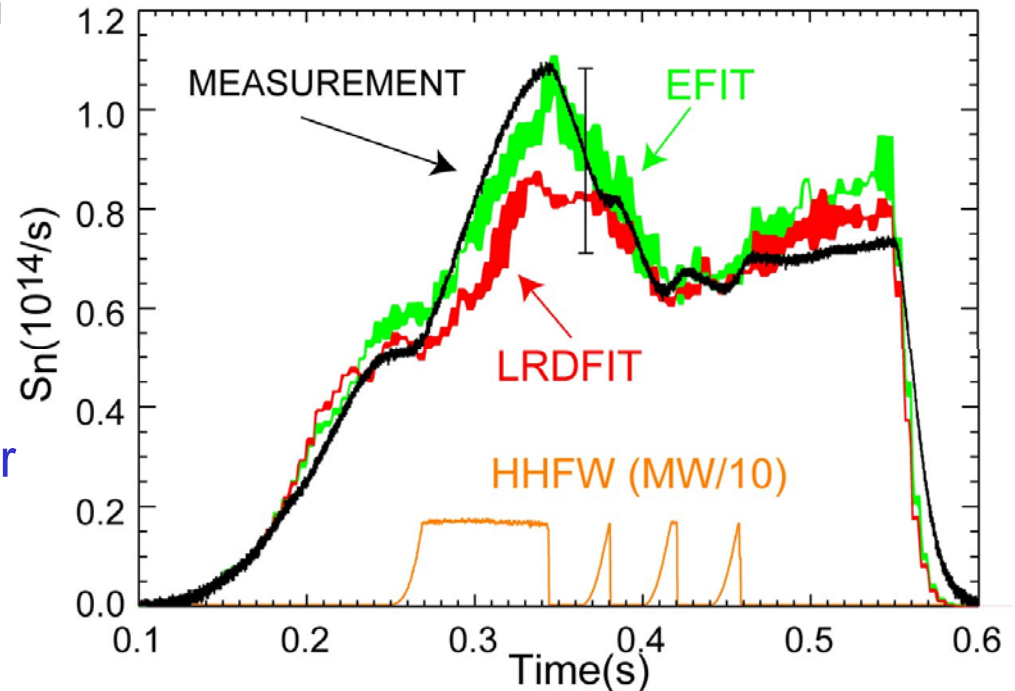

Moving Onset Density Layer away from Antenna Facilitated by Lithium Coating Pumping

- Onset density, n_{onset} , for perpendicular fast-wave oscillation[5]

$$\longrightarrow n_{onset} \propto B \times k_{||}^2 / \omega$$

Wave onset occurs where $n_e \approx n_{onset}$, i.e. near $R=1.52\text{m}$

n_e near antenna remains below n_{onset} during HHFW pulse

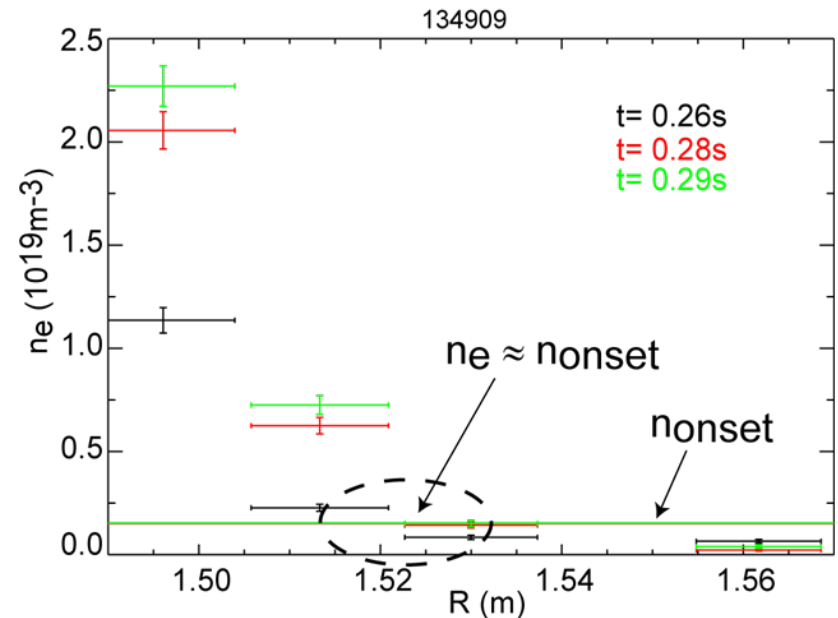
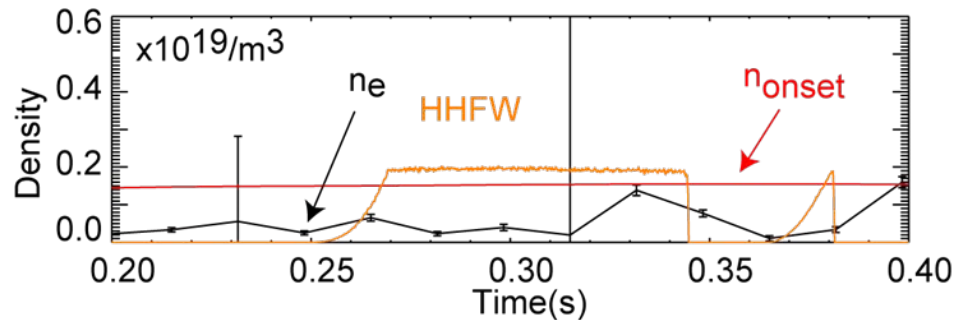

[5] J.C. HOSEA, *et al.*, Phys. Plasmas **15** (2008) 056104

Conclusion

- HHFW Heating of L-mode plasma
 - Near doubling of the density profile of the higher-energy fraction of the fast ions has been measured by FIDA
- HHFW heating of NBI-induced Elm-free H-mode plasma
 - T_e increases over most of the radial profile.
 - 1/2 of antenna power captured with the LCFS
 - 2/3 of power inside LCFS absorbed by electrons
 - 1/3 of power inside LCFS absorbed by fast-ions
 - Fast-ion diagnostics FIDA and NPA observed no changes during HHFW heating
- Edge physics effects
 - Improved core coupling partly attributed to first wall lithium coating, which keeps the $n_e < n_{\text{onset}}$ in front of the antenna
 - Infrared radiation measurements show local power flux on divertor plates reaches $\sim 1 \text{ MW/m}^2$ per MW of HHFW heating