

# Facility & Diagnostic Overview for 2009 - 11 and Beyond

**Masa Ono, PPPL**  
*and the NSTX Research Team*

**25th NSTX PAC Meeting**  
**Conference Room LSB-B318, PPPL**  
**Feb 18-20, 2009**

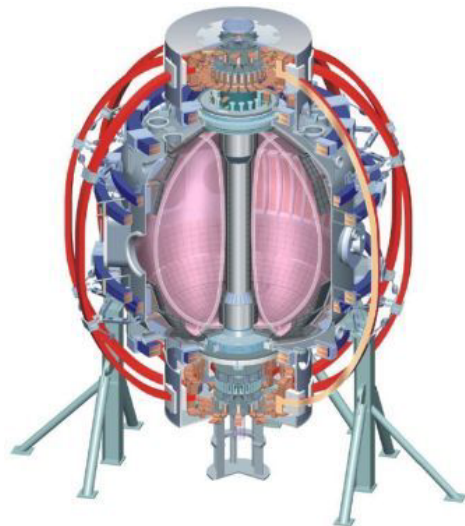

College W&M  
Colorado Sch Mines  
Columbia U  
CompX  
General Atomics  
INEL  
Johns Hopkins U  
LANL  
LLNL  
Lodestar  
MIT  
Nova Photonics  
New York U  
Old Dominion U  
ORNL  
PPPL  
PSI  
Princeton U  
Purdue U  
SNL  
Think Tank, Inc.  
UC Davis  
UC Irvine  
UCLA  
UCSD  
U Colorado  
U Illinois  
U Maryland  
U Rochester  
U Washington  
U Wisconsin

Culham Sci Ctr  
U St. Andrews  
York U  
Chubu U  
Fukui U  
Hiroshima U  
Hyogo U  
Kyoto U  
Kyushu U  
Kyushu Tokai U  
NIFS  
Niigata U  
U Tokyo  
JAEA  
Hebrew U  
Ioffe Inst  
RRC Kurchatov Inst  
TRINITI  
KBSI  
KAIST  
POSTECH  
ASIPP  
ENEA, Frascati  
CEA, Cadarache  
IPP, Jülich  
IPP, Garching  
ASCR, Czech Rep  
U Quebec

# Talk Outline

- **FY 2008 Plasma Operations**
- **FY 2008 Outage Activities**
- **FY 2009-2011 Facility / Diagnostic Upgrade Plan and Status**
  - **High Harmonic Fast Wave Upgrades**
  - **Multi-pulse Thomson Scattering Extra Channels**
  - **Beam Emission Spectroscopy**
  - **Motional Stark Effect - Laser Induced Florescence**
  - **Upgraded Boundary Physics Capability**
  - **Liquid Lithium Divertor Target**
  - **Fast Ion D-Alpha Diagnostic (described in backup)**
- **FY 2009 - 2010 Facility Plan**
- **Major Upgrades Status: New Center-stack and 2nd NBI**
- **ASIPP Collaboration Activities**
- **Summary**

# NSTX Completed Successful FY 2008 Run

- NSTX Run started on Feb. 18 and completed on July 14, 2008.
- NSTX has completed 16.6 weeks meeting the FY 08 operational Joule milestone of 15 weeks. Produced 2571 plasma shots in 16+ weeks, most plasma shots per year. 40% increase in shots/week from 2004.
  - Improved control computer reliability
  - LITER conditioning
- Dual LITER system has been working flawlessly. LITER also largely eliminated He-GDC which improved operational efficiency. Dual LITER were reloaded with lithium three times (total ~ 200g) during the operations.
- Lithium shaker was tested. It appears to reduce the density and impurity radiation during the long-pulse ELM-free H-mode discharges.
- The EF/RWM feedback control system are now routinely used as a tool for advanced long-pulse operation.

# Outage Completed for FY 09 Run

## LLD Deferred to FY 10 Due to Manufacturing Challenge

### Upgrade Activities:

- HHFW Antenna upgrade to provide a double power feed installation complete - external piping installation on-going
- Enhanced Boundary Physics Capability
  - 20 ch three view divertor bolometer
  - Edge sample probe
  - Dual Lithium shakers to complement dual LITER
- LLD proto-type plate trial fitted, PPPL -SNL LLD work on going in preparation for the summer 2009 installation
- BES Vacuum Vessel Ports/Interfaces Complete
- MSE-LIF Platforms complete

### Operational Readiness:

- Inspection and maintenance of all TF joints completed
- TIV/Shutter System upgrades for improved control/more channels
- Neutral Beams ready for the run with 2 spare ion sources
- 14-day bake-out completed for improved vacuum conditions
- FY 09 Run to start in mid-February continue to June

# Extensive Diagnostic Systems Operational with Strong Collaboration Contributions

## *Collaboration contributions*

### MHD/Magnetics/Reconstruction

Magnetics for *equilibrium reconstruction (CU)*  
Diamagnetic flux measurement  
Halo current detectors  
High-n and high-frequency Mirnov arrays  
Locked-mode detectors  
RWM sensors (n = 1, 2, and 3)

### Profile Diagnostics

Multi-pulse Thomson scattering (30 ch, 60 Hz)  
T-CHERS:  $T_i(R)$  and  $V_\phi(r)$  (51 ch)  
P-CHERS:  $V_\theta(r)$  (75 ch)  
*MSE-CIF (15 ch) (Nova)*  
*FIRETIP interferometer (119mm, 6 ch) (UCD)*  
Midplane tangential bolometer array (16 ch)

### Turbulence/Modes Diagnostics

*Tangential microwave high-k scattering (UCD)*  
*Microwave reflectometers (UCLA)*  
*Ultra-soft x-ray arrays – tomography (JHU)*  
*Fast X-ray tangential camera (2ms) (PSI)*

### Energetic Particle Diagnostics

Neutral particle analyzer (2D scanning)  
SSNPA  
Fast lost-ion probe (energy/pitch angle resolving)  
Neutron measurements  
*Fast Ion  $D_\alpha$  profile measurement (UCI)*

### Edge Divertor Physics

*Reciprocating Edge Probe (UCSD)*  
*Gas-puff Imaging (2ms) (Nova)*  
*Fixed Langmuir probes (24) (ORNL)*  
Edge Rotation Diagnostics ( $T_i$ ,  $V_\phi$ ,  $V_{pol}$ )  
*1-D CCD  $H_\alpha$  cameras (divertor, midplane) (ORNL)*  
*2-D divertor fast visible camera (Nova)*  
Divertor bolometer (12 ch)  
*IR cameras (30Hz) (3) (ORNL)*  
Tile temperature thermocouple array  
Dust detector  
Edge Deposition Monitors  
*Scrape-off layer reflectometer (ORNL)*  
*Edge neutral pressure gauges (U. Washington)*

### Plasma Monitoring

*Fast visible cameras (Nova)*  
Visible bremsstrahlung radiometer  
Visible survey spectrometer  
UV survey spectrometer  
*VUV transmission grating spectrometer (JHU)*  
*Visible filterscopes (ORNL)*  
*Graphite Tile Analysis (SNL)*  
*X-ray crystal spectrometer (astrophysics)(LLNL)*

# NSTX Near Term Upgrade Plan

## Strong Collaboration Components

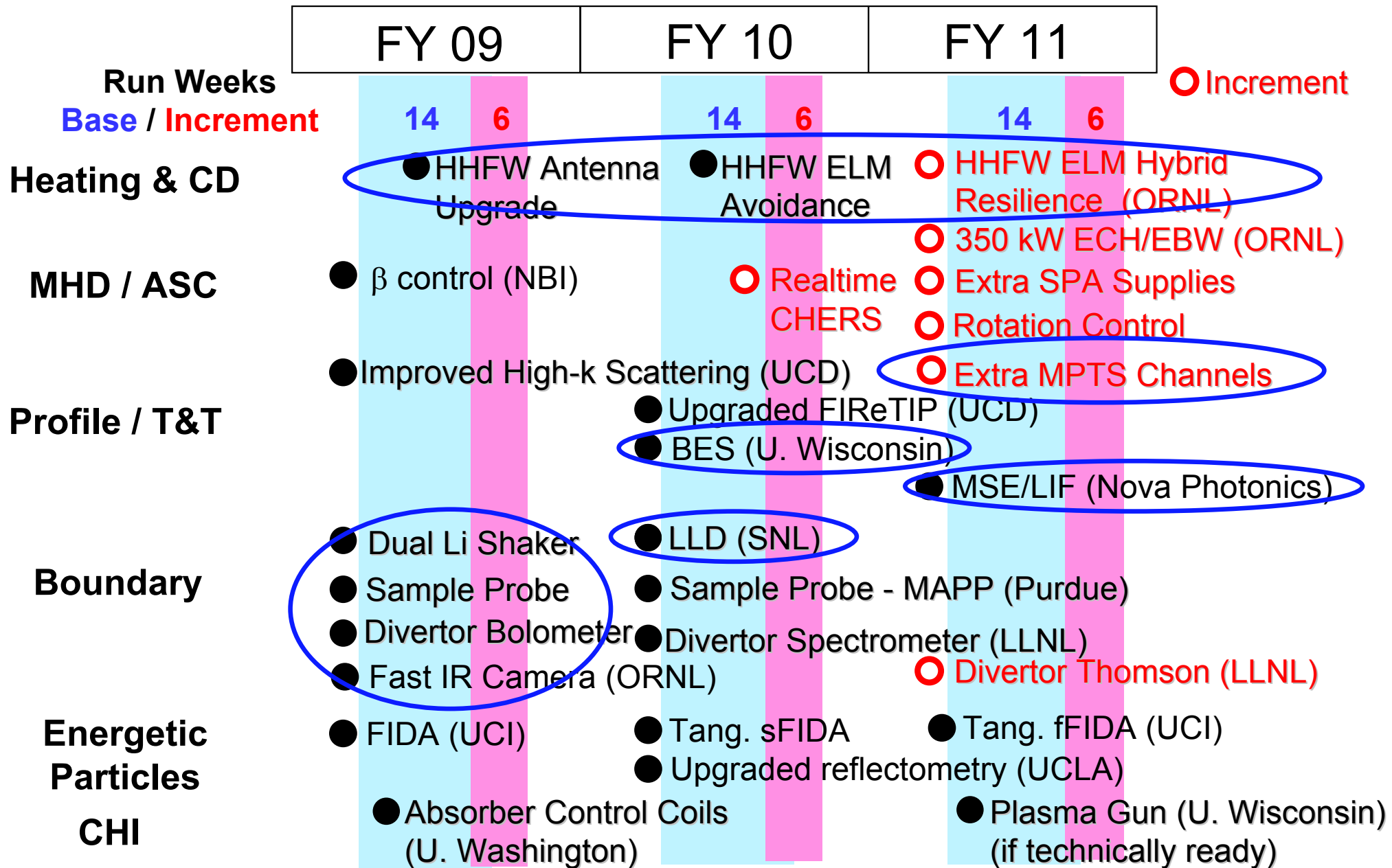

# HHFW Double-Feed Antenna Upgrade

## Upgraded Antenna Main Features

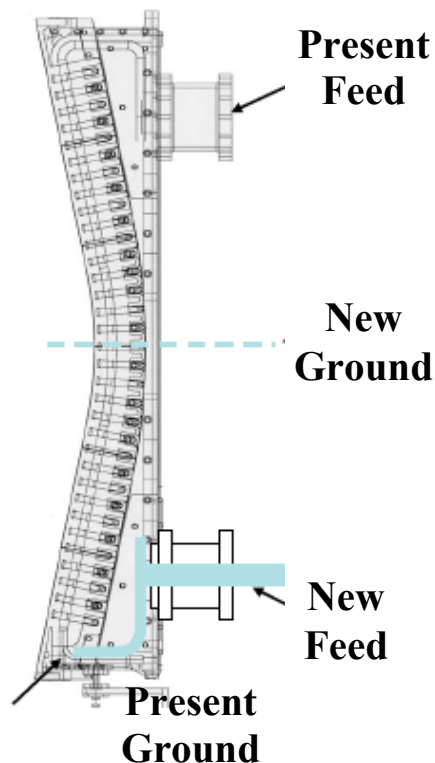

- Symmetric feed
- Ground at antenna mid-plane
  - Originally planned ceramic ground
  - Changed to Cu ground for strength
- Maximum radiation at mid-plane
- Power capability should be up by a factor of 2

## Antenna Installation is completed

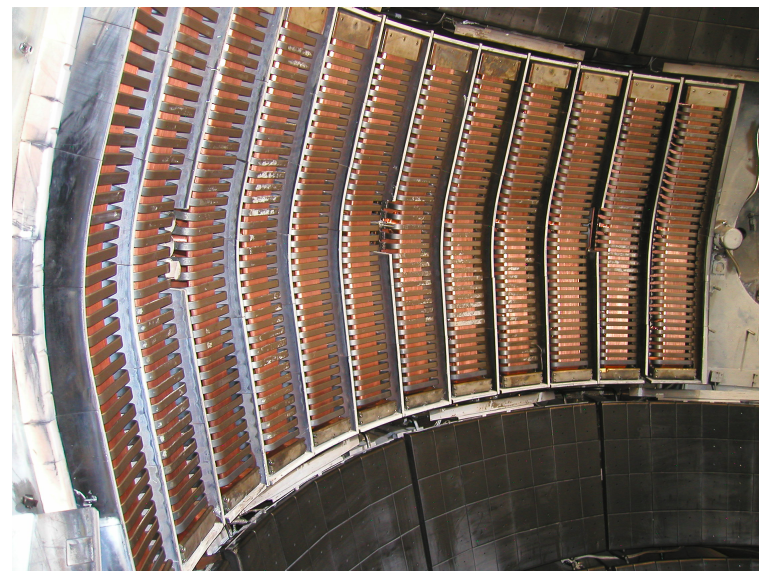

- Completed in-vessel installation of new straps and lower feedthroughs
- External loop being installed to be available during FY 09 run
- HHFW ELM Avoidance system to be developed in FY 09 and implemented in FY 10
- HHFW Hybrid ELM Resilience system for FY 11 as incremental upgrade in collaboration with ORNL

# Install Additional 10 Measurement Locations for Multi-Point Thomson Scattering System

- Analysis of NSTX MPTS database shows region in edge and core where additional channels would improve resolution of common profile features

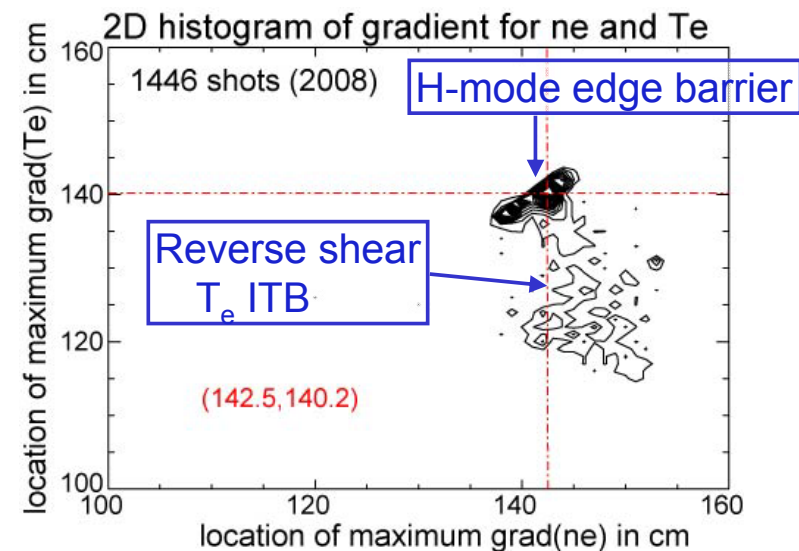
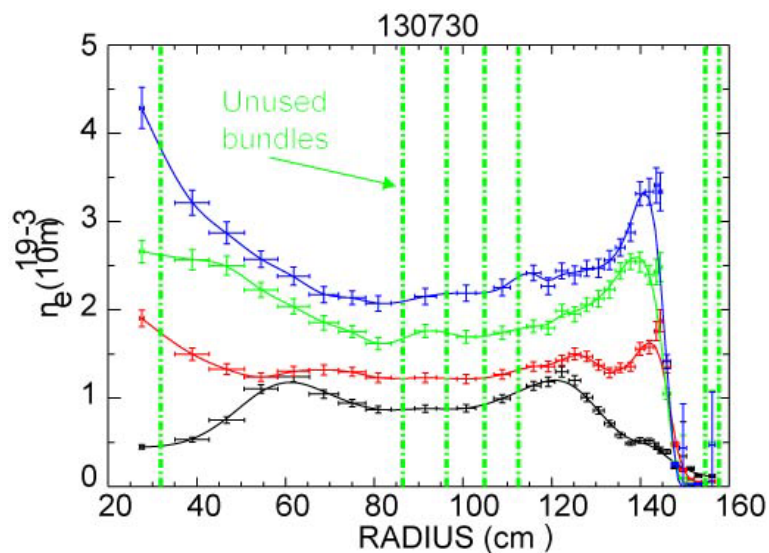

- Instrument some currently unused fiber bundles and split other bundles already in use in outboard edge region
- Implement in FY 10 as a high priority (incremental) upgrade to support FY11 Joint Research Milestone



# Beam Emission Spectroscopy for FY 10

## Measure Longer Wavelength Density Fluctuations in the Plasma Core

Together with high-k to provide most comprehensive turbulence diagnostic set

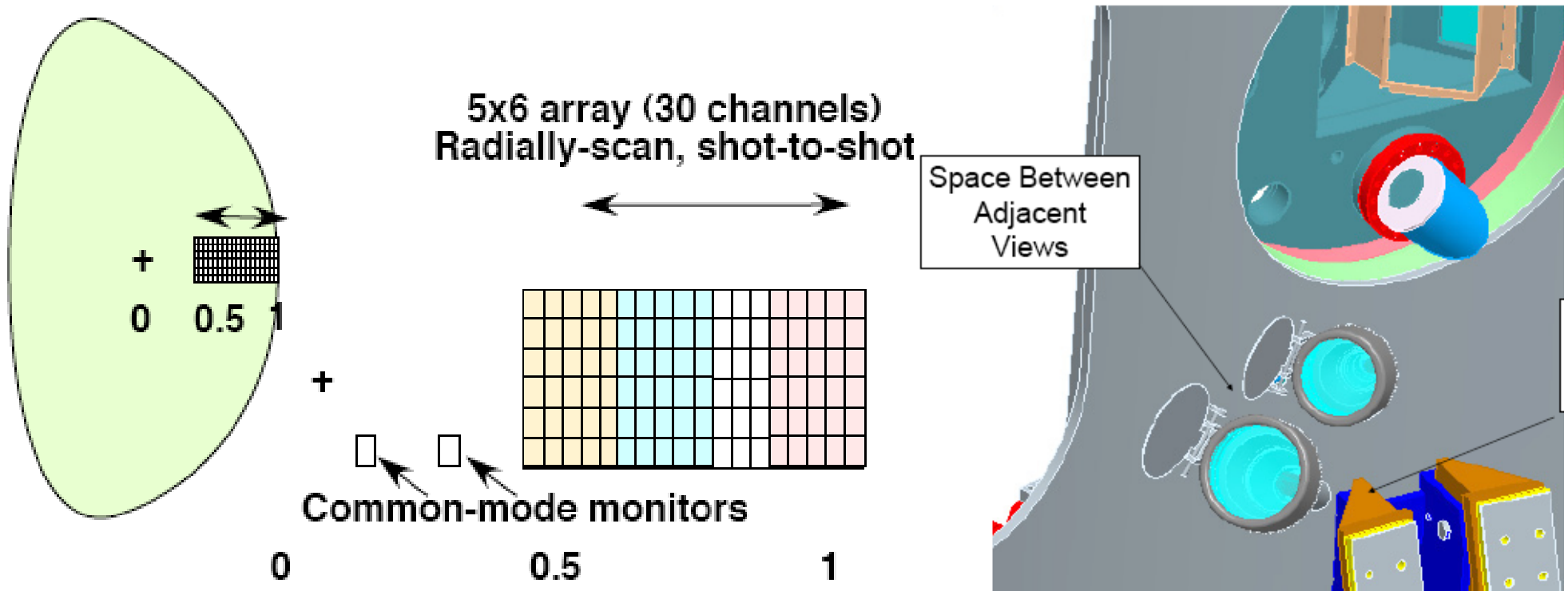

### BES Diagnostic Status:

- BES viewing ports installed in FY 08 and lens being procured in FY 09
- U. Wisconsin manufacturing detectors to be delivered in two stages (16 & 16) to be available for FY 10 run.
- Cable trays and diagnostic room readied
- Fiber procurement and fiber holder design being finalized for fabrication
- Cost & schedule reviewed and on track for the summer outage

# Motional Stark Effect -Laser Induced Fluorescence

## Nova Photonic Innovative Diagnostic Initiative

- The MSE-LIF will also provide field pitch information without heating beam and also provide information for the total plasma pressure and the radial electric field for transport, MHD, and energetic particle research.
- Extension of mezzanine and relocation of two racks to make space for DNB completed during 2008 outage
- Design work for AC power services and cable tray complete
- The main PPPL tasks are:
  - reconfiguring an existing port on the vessel for the DNB/laser flight tube,
  - modifying a port cover to accommodate a new window and shutter for the viewing optics,
  - providing AC power and water to DNB/laser,
  - resolving a number of interferences (significant scopes)
- The main Nova Photonics tasks are:
  - reconfiguring the DNB for installation on the NSTX platform,
  - design and fabrication of magnetic shielding for beam,
  - take delivery of laser, and lab testing of entire system

Vacuum interface will be installed during the FY 09 outage and complete the external system during the F10 outage to be commissioned during the FY 11 Operation

To Measure  $E_r(r)$ ,  $B(r)$

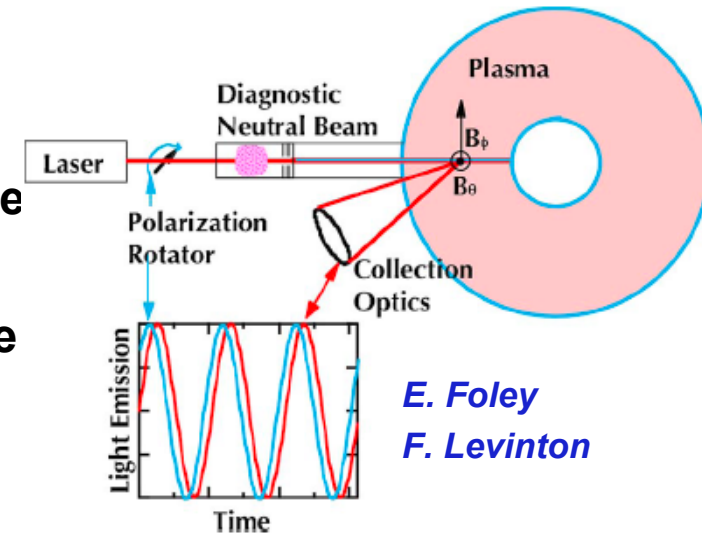

*E. Foley*  
*F. Levinton*



New MSE-LIF Platform

# Boundary Physics Capability for FY 09 Joule Milestone

## NSTX Lithium Research Attracting Interest Internationally

Dual Liquid Lithium Evaporator  
For Li wall coatings

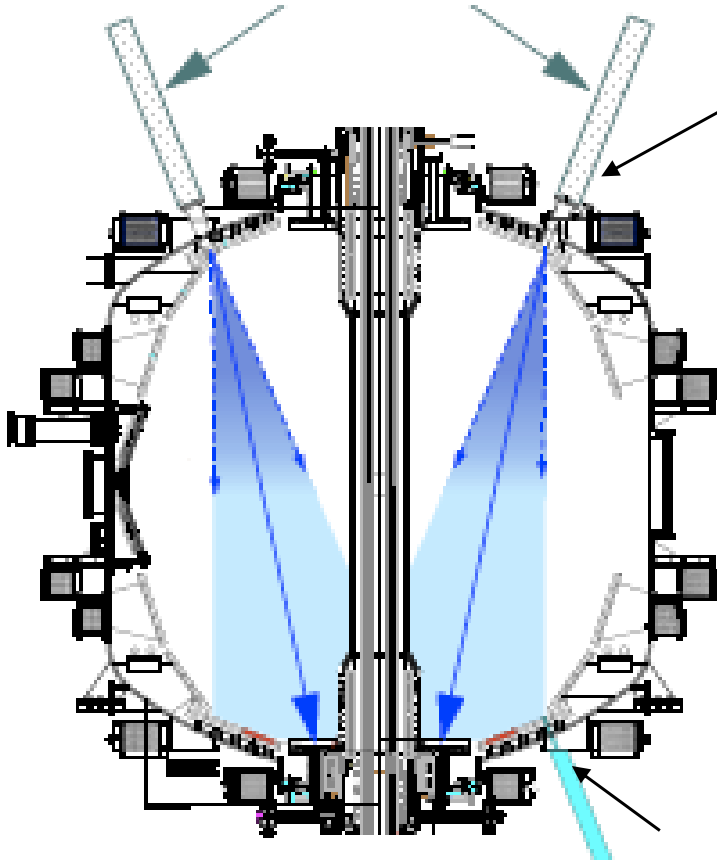

Dual Lithium Powder Dropper for  
Li injection into plasma

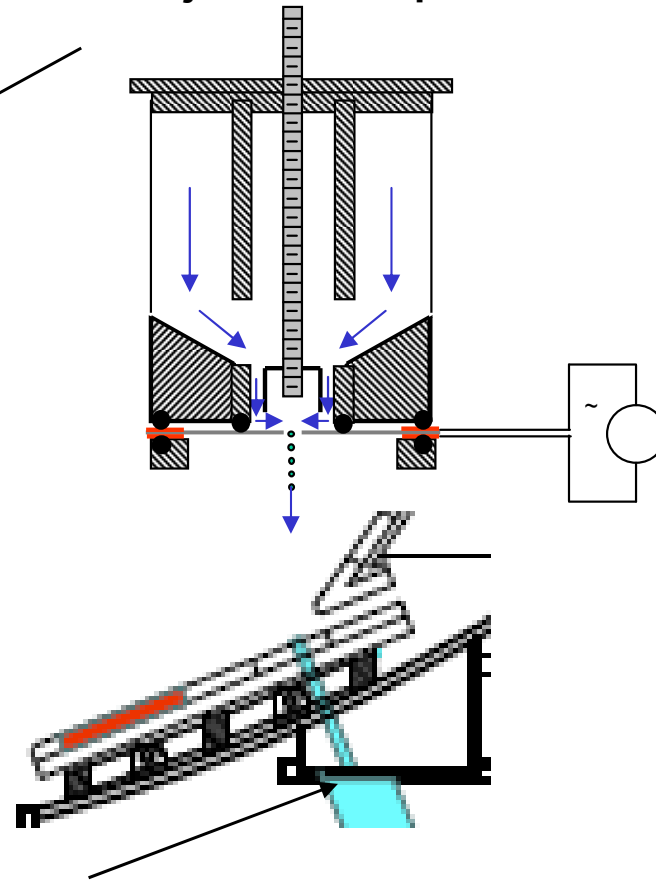

SAMPLE PROBE for  
retention measurements  
and surface analysis

*Purdue U*

Three-view Divertor  
Bolometer Installed for  
divertor radiation

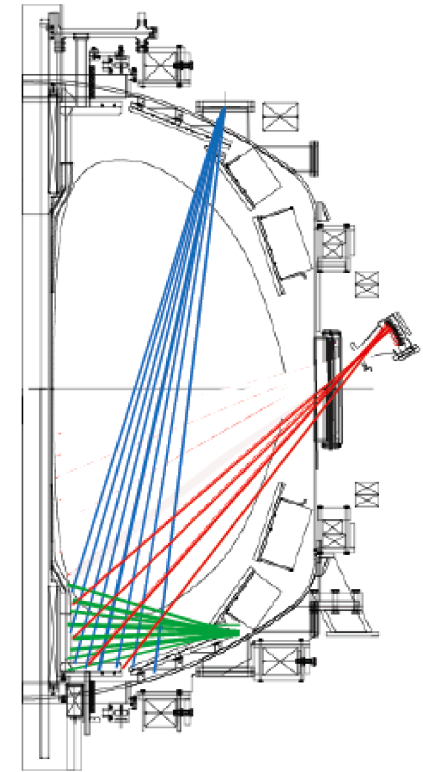

Fast IR Camera  
(ORNL) installed for  
divertor heat flux

# LLD is Critical for FY 09 Outage

## LLD Plate Fabrication More Challenging Than Anticipated

- Holding weekly teleconferences with SNL personnel
- Pursuing dual-track (SNL/PPPL) approach to mitigate fabrication risk of moly-coated plates

### • SNL Status

- All plates machined; First plate successfully brazed.
- Arrival at PPPL Early April (total: 4 plates for installation + 2 spares).
- Control Rack design being completed. Parts being purchased. Software starting.

### • PPPL Status

- PPPL has backup strategy/design for LLD (if necessary)
- Decide whether to continue with PPPL fabrication when first SNL plates received.
- Active engineering of controls, cabling, cable trays, AC distribution, and diagnostic sensors in progress.

**Scheduled to be installed in August 2009**

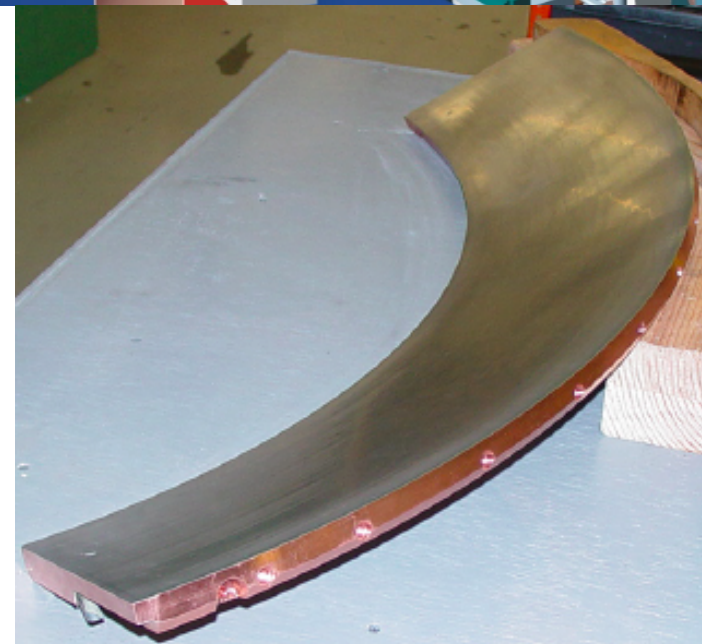
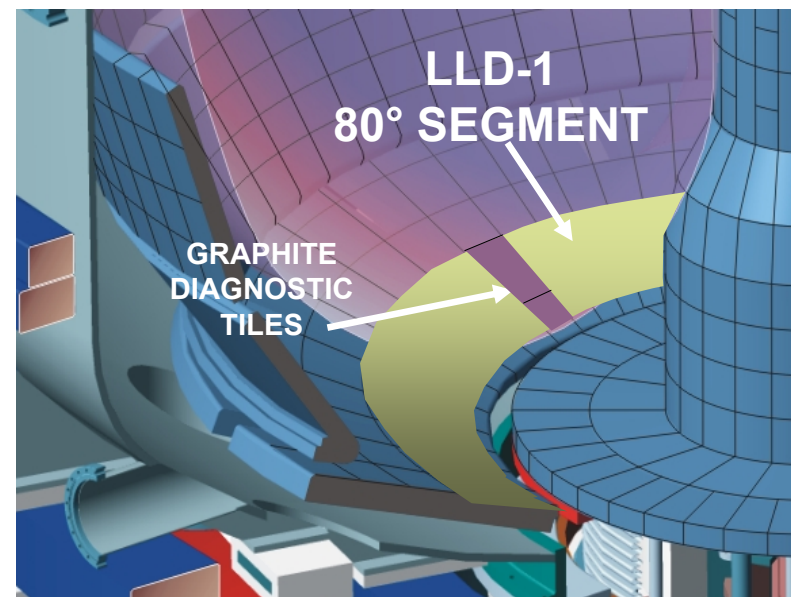

**Successfully Brazed SNL LLD Plates**

# LLD Diagnostic Tile Sensors

## NSTX PAC Recommended Adequate Diagnostic Capability for LLD

- Graphite tile transition regions between segments contain thermocouples, Langmuir probes, and magnetic & current sensors

- **GAP-B Tile (PPPL Student+ UIUC)**
  - 99 Langmuir Probes  
(33 sets of 3 toroidal rows)  
[UIUC triple probe electronics]
- **GAP-E Tile (zweben)**
  - 2 BEAP bias electrodes
  - 2 TC (in IR Camera FOV)
  - 5 Langmuir Probes
    - Using Existing electronics
- **GAP-H Tile (Gerhardt)**
  - 5 2D magnetic sensors for control
  - 2 TC (in IR Camera FOV)
    - Using Existing electronics
- **GAP-K Tile (Zweben)**
  - 2 BEAP bias electrodes
  - 5 Langmuir Probes
  - 2 TC (in IR Camera FOV)

LLD diagnostic scopes are being re-examined to minimize the cost while retaining key capabilities

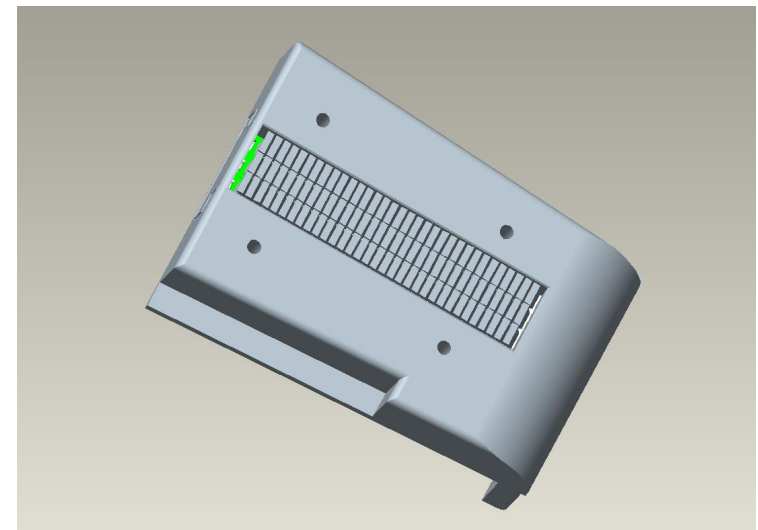
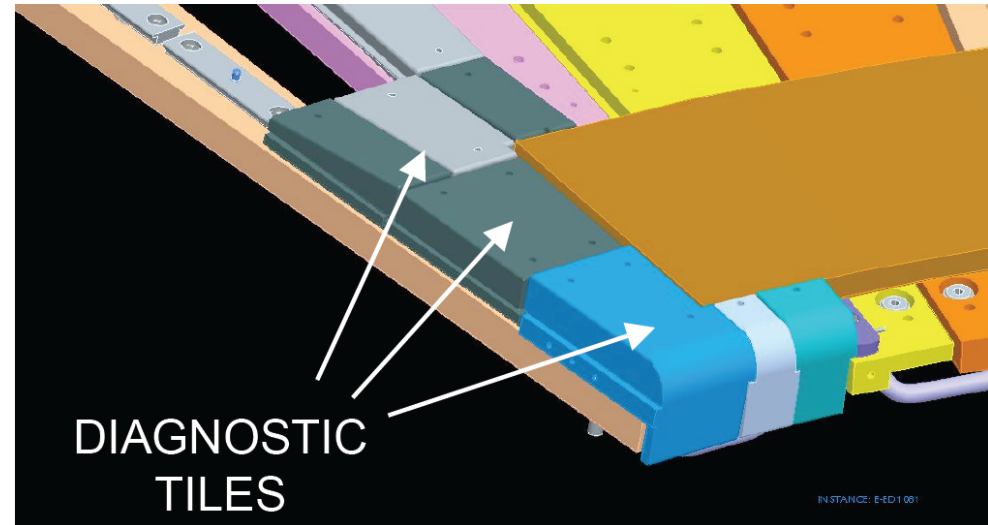

Langmuir probe tile (Thesis research)

# Facility Related Events and Activities

## Longer Term Facility Upgrade Plan Evolved

- **NSTX PAC-23 Meeting (Jan. 22 - 24, 2008)** [Presented a plan with sub-cooled TF for longer pulse and 2nd NBI for full non-inductive operations.]
- **FWP Budget Planning Meeting (Mar. 11 - 12, 2008)**
- **Letter from DOE Under Secretary of Science (May 22, 2008)**  
"Proposed upgrades for the Spherical Torus experiment at PPPL can keep this facility at the forefront of fusion science research in the world well into the future."
- **Five Year Plan and Facility Reviews (July 28 - 31, 2008)**
  - Positive reviews received on both facility performance and 5 Year Plan.
  - CS and NBI Upgrades Plan strongly endorsed by both reviews.
- **New Center-Stack (instead of TF sub-cooling) for higher  $B_T$  and  $I_p$  narrows collisionality and other gaps identified FESAC TAP.**
- **NSTX CS and NBI Upgrades:**
  - Germantown OFES visit (Dec. 3, 2008)
  - CD-0 (Mission Needs) submitted (Jan. 2009)
  - CD-0 ESAAB Equivalent Review (Feb. 23, 2009)
  - Aim for CD-1 (Conceptual Design) approval by end of this calendar year

# Modular design of NSTX enables removal of present CS and replacement with a new higher-performance CS

- Present CS has been removed and re-installed several times for maintenance and modifications
- New CS would have larger radius for increased conductor area and toroidal field current, while maintaining low aspect ratio  $A \sim 1.5$
- Construction tolerance requirements are similar to present NSTX CS

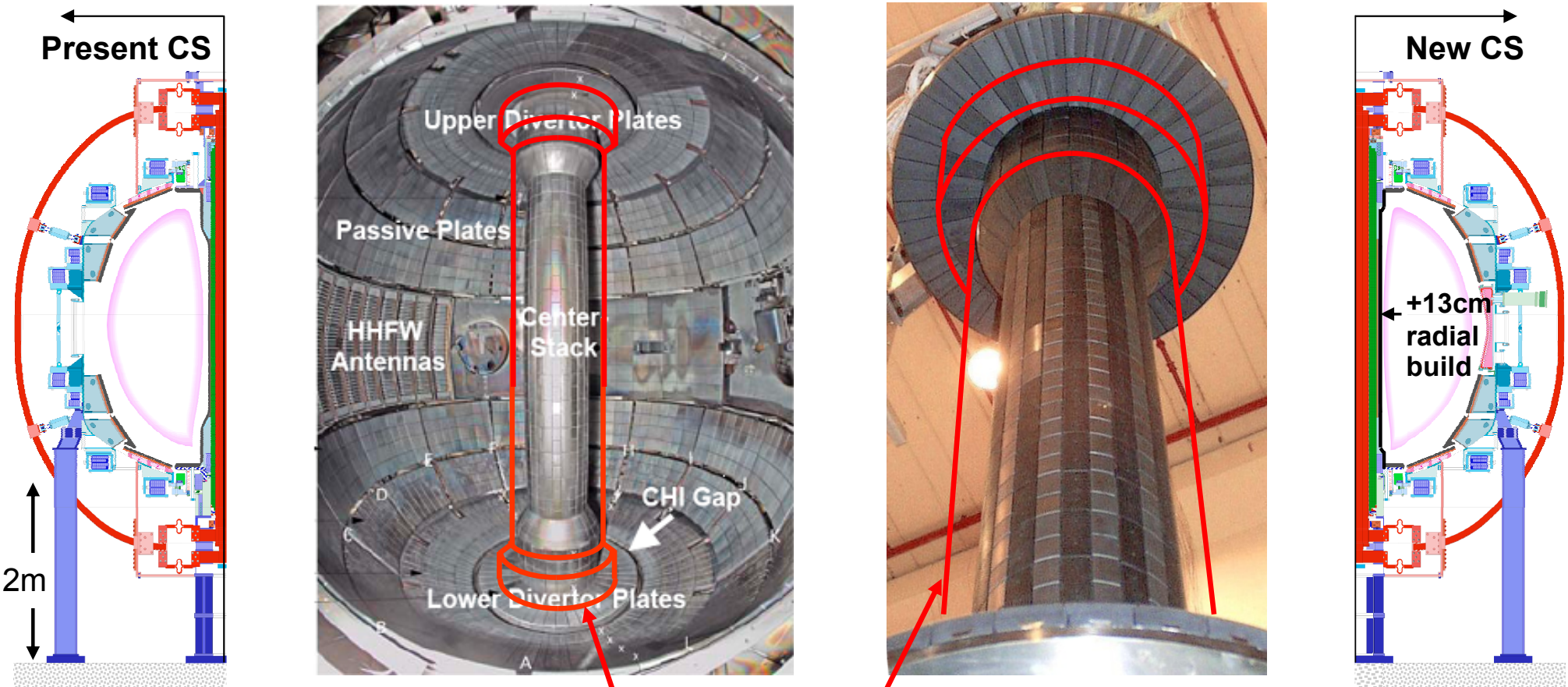

*Approximate outline of new Center-Stack*

# 2nd NBI Will Utilize One of NBI from TFTR

Enables Doubling of the NBI Heating Power with Improved CD Capability

- PPPL has extensive experience operating, maintaining, refurbishing NBI
- NBI based diagnostics (T-CHERS, P-CHERS, MSE, FIDAs) will remain with the present beam)

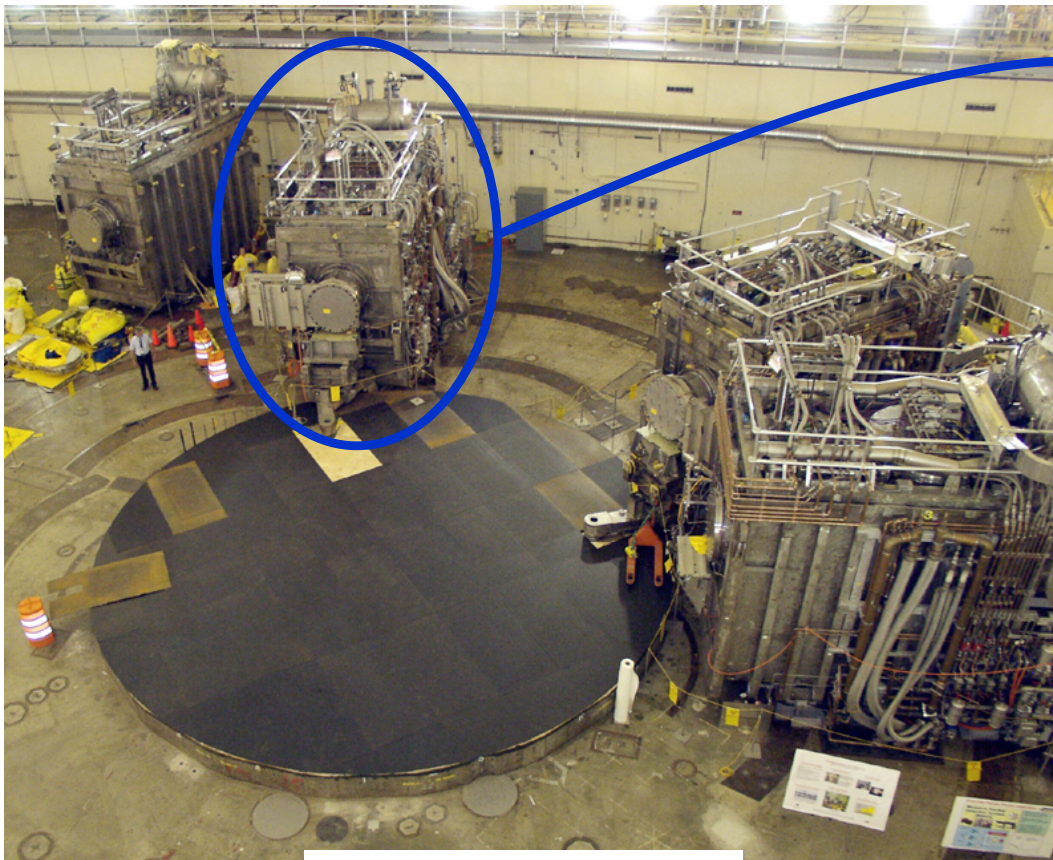

TFTR test cell

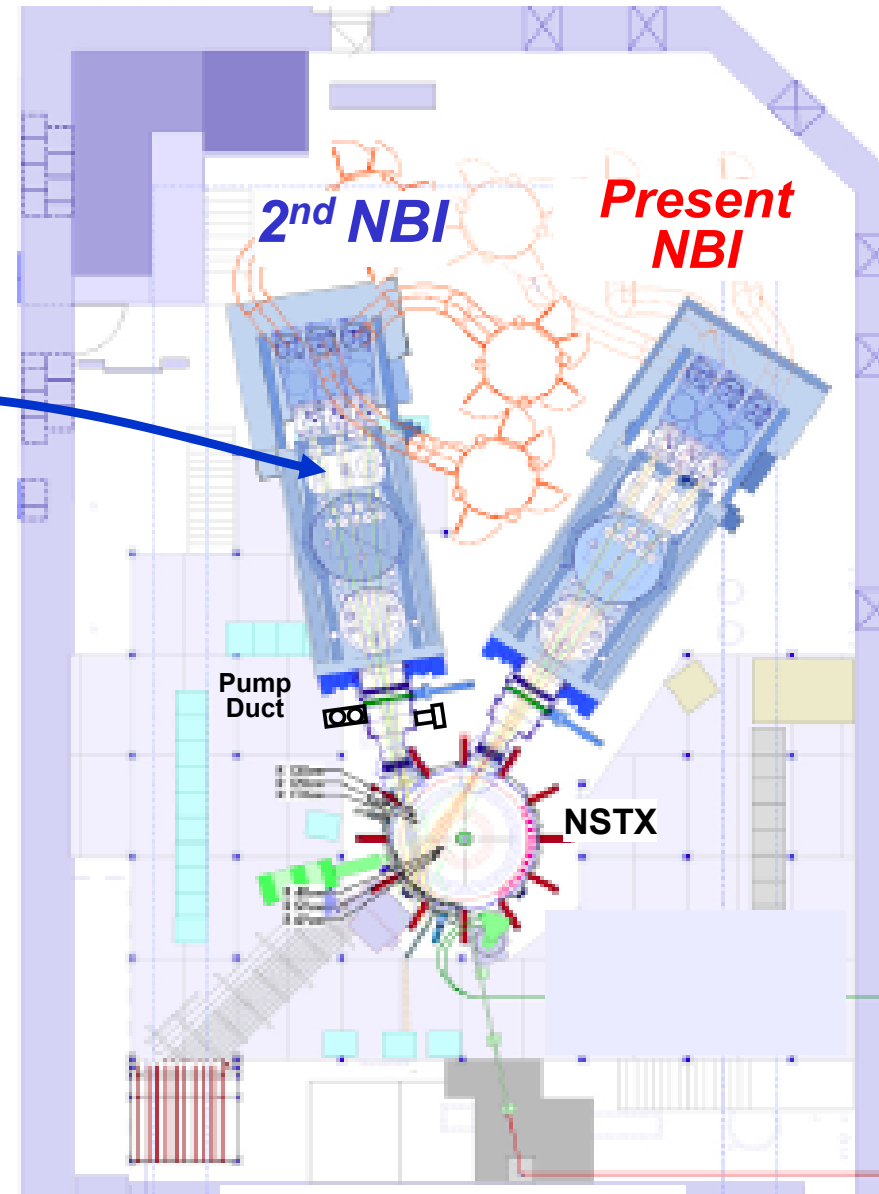

NSTX test cell



# **NSTX Upgrade Project**

## **Need for Coordination with NSTX Operations**

- **Longer lead time to perform key design and R&D up front, based on NCSX lessons learned**
- **Aiming to develop more detailed cost and schedule by CD-1**
- **Similarity of schedules for both projects**
- **Significant cost savings for doing both CS and NBI at same time utilizing NSTX personnel for assembly and installation**
- **DOE desire to have as one upgrade project for CS and NBI**
  - **Understand desire to get CS as soon as possible**
  - **Not confident at this time CS can be implemented before FY13**
- **And, doing CS first (with delayed or no NBI) remains an option.**

# Schedule for CS & NBI Upgrades Proposed in "Mission Need Statement" for CD-0

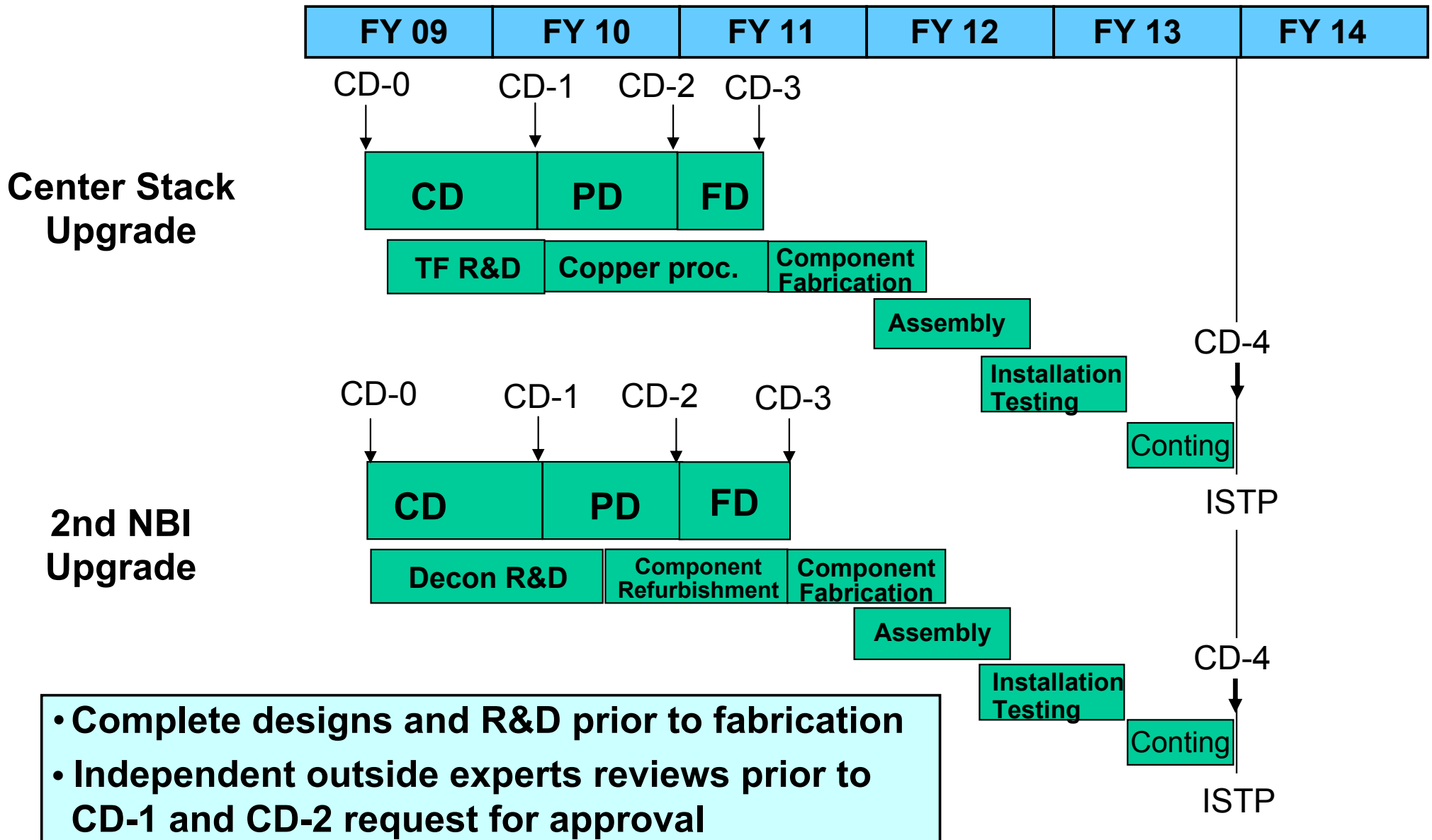

# Detailed Plan Developed for the 2009 Outage

## LLD and BES Are Two High Priority Items

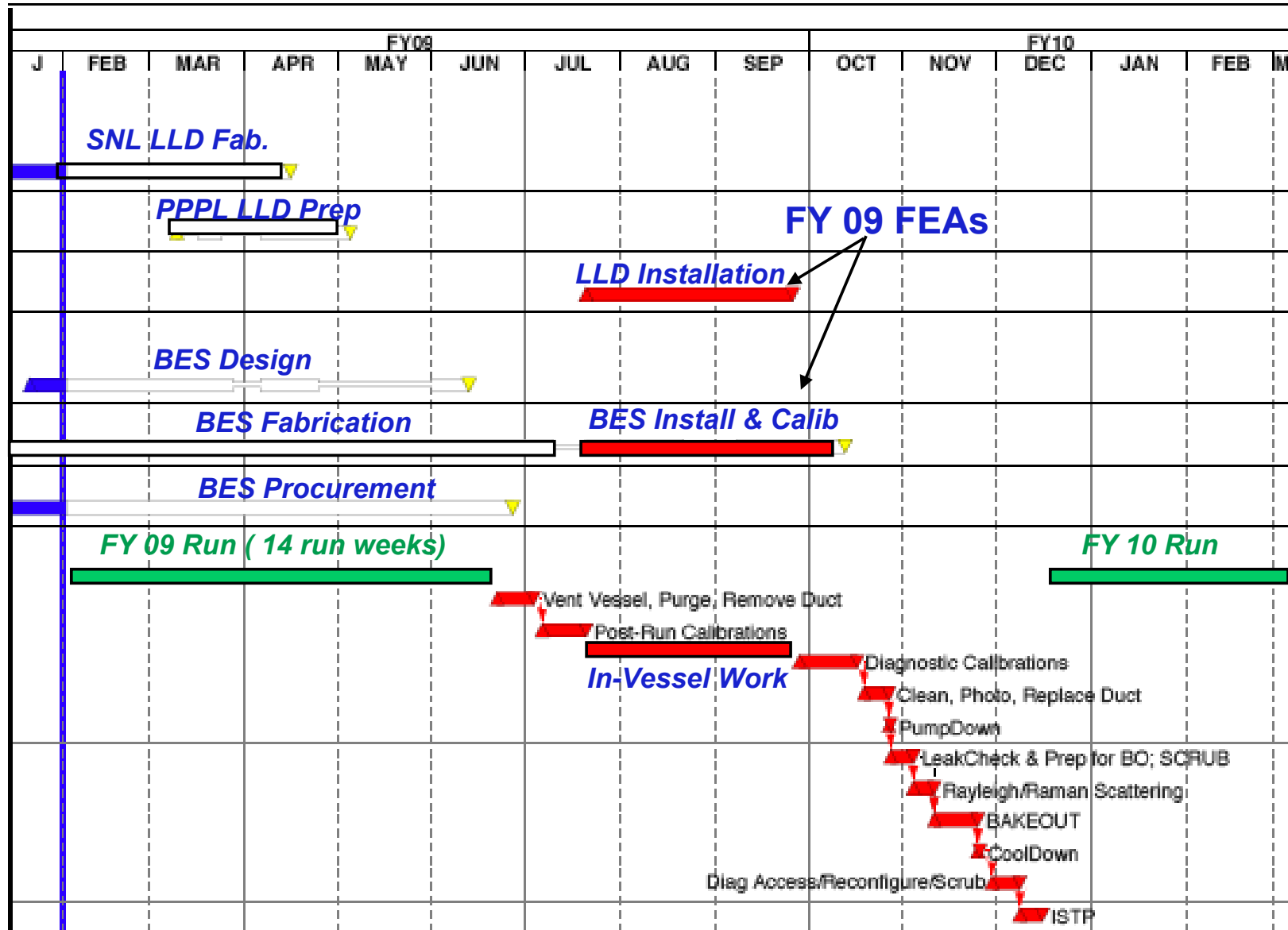

# FY 2009 20-Run-Week Plan Also Developed

## Aiming to start FY 10 Run ASAP

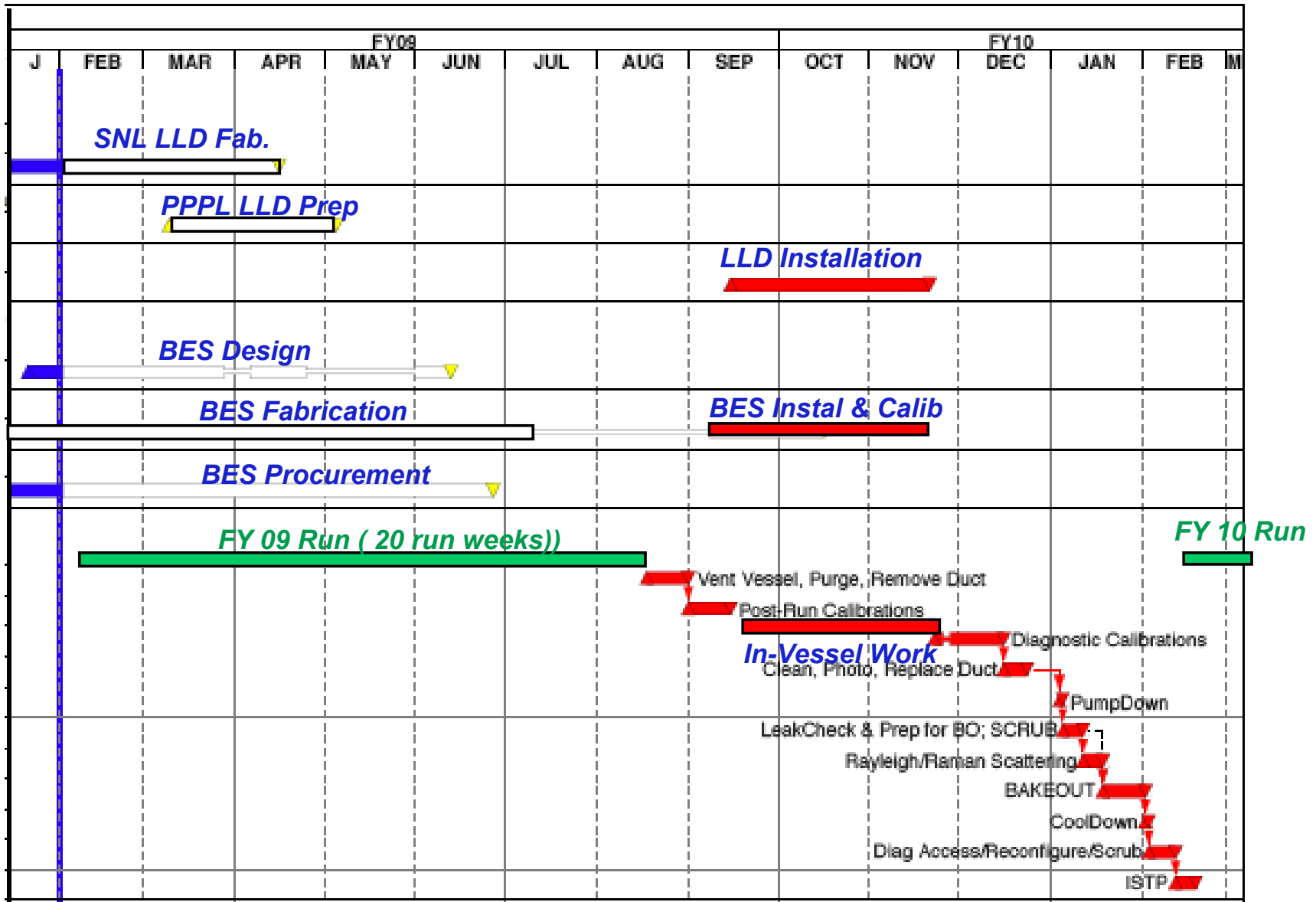

# Detailed Cost and Schedule Developed for Upgrades

**Considerable challenges to perform near term as well as longer term upgrades while operating NSTX facility:**

- **Responsible engineering managers designated to manage each upgrade**
- **Each upgrade manager performs detailed up front cost and schedule**
- **Cost and Schedule independently reviewed by Engineering Department for FWP**
- **All ongoing projects incorporated into the integrated planning to for adequate resource availability**

# High Priority Incremental Facility Utilization and Upgrades

1. Increase the facility operation from 14 run weeks to 20 run weeks
2. MPTS Upgrades for enhanced  $T_e$  and  $n_e(R, t)$  resolution for H-mode pedestal and boundary physics
3. LLD Enhancement to increase pumping capability with more lithium and/or increase pumping area such as the inboard divertor.
4. Two post doctoral researchers to support high priority NSTX diagnostics and research
5. HHFW Hybrid ELM Resilience system for improved H-mode operation
6. ~ 1 MW ECH/EBW heating system for plasma start-up and EBW heating research
7. Real-time CHERS for plasma rotation control capability
8. 2nd Switching Power Amplifiers for improved EF/RWM/RMP spectrum control for MHD and ELM physics
9. Divertor Thomson in collaboration to enhance high priority divertor research

# ASIPP-PPPL Collaboration Activities

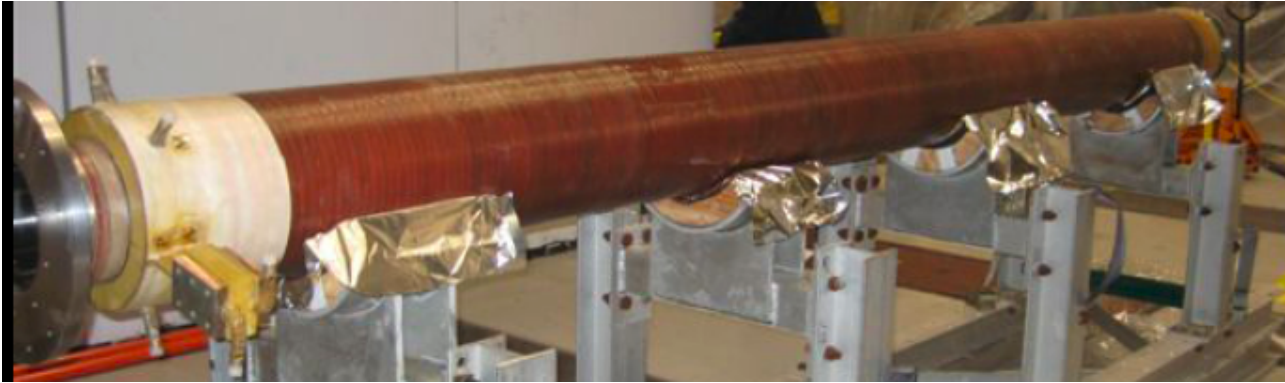

- **NSTX OH Spare manufactured by ASIPP: Project Engineer - J. Chrzanowski**
  - NSTX is being tested at PPPL. Passed high-pot tests
  - NSTX will complete adapting fixtures for future installation
- **EAST diagnostic status**
  - ECE grating polychromator and NPA calibration source arrived at ASIPP
  - Germanium PHA detector arrived at ASIPP
  - Neutron ( $^3\text{He}$ ) detectors arrived at ASIPP
  - NPA completed check out and being ready to be shipped
- **ASIPP researchers' visits to NSTX/PPPL for tokamak code training**
  - Two researchers are visiting for one year. Learning tokamak simulation and analysis codes (TSC, TRANSP, etc.)
- **Assisting EAST operations**
  - The head of NSTX plasma operation, Dennis Mueller has been visiting EAST to help the plasmas operations since its successful first plasma in 2006.

# NSTX Has Many Exciting Opportunities Ahead

## Optimized Facility Plan Developed for FY 2009 - 2011

- **Very productive FY2008 run with all milestones completed**
- **New Capability for FY 2009:**
  - Three view Divertor Bolometer / Edge Sample Probe
  - Dual Lithium Shaker system together with Dual LITER system
  - HHFW antenna upgrade
- **Facility upgrades to support FY 2010-2011 research plan**
  - Liquid Lithium Divertor target in FY10
  - BES to complement High-k in FY 10
  - MSE-LIF to complement MSE-CIF in FY 11
  - Enhancement: Tang. FIDA, FIReTIP, Wave Reflectometry, FY 10-11
- **Incremental budget greatly enhances science output**
  - Increase the run weeks by ~ 40 %
  - MPTS extra channels in FY 11
  - Extra SPA, NCC, EBW/ECH
  - Real time-CHERS, Divertor Thomson

- **NSTX New CS and 2nd NBI enable fully non-inductive long pulse operation to greatly improve design of future ST devices.**
  - Preparation toward CD-1 review has started.



# Back-up Slides

# FIDA diagnostic Successfully Implemented on NSTX

- Density profile of fast ions (15 – 65 keV) deduced from Doppler-shifted  $D_{\alpha}$  emission by energetic neutrals created by charge-exchange with NBI neutrals

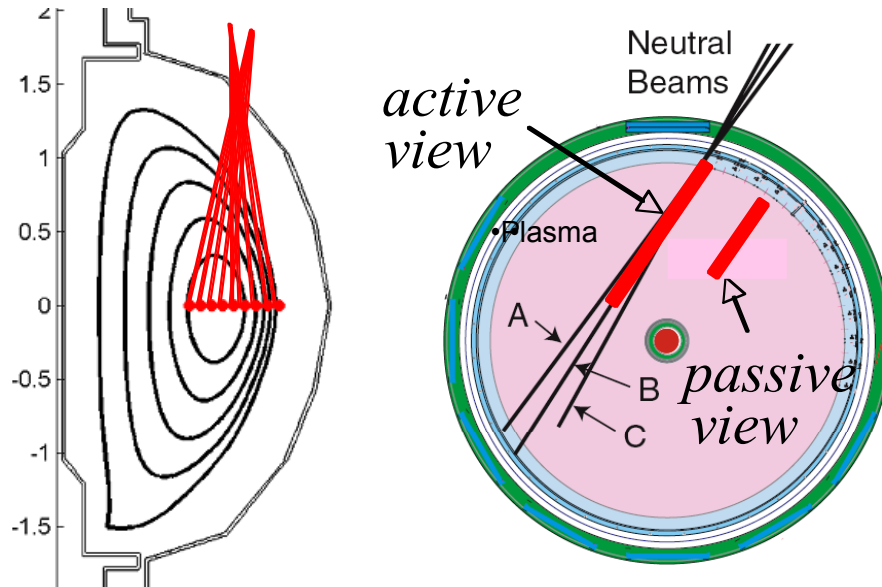

- During TAE avalanches, measured fast-ion losses up to 30%
  - Consistent with neutron rate drop
  - Profile remains peaked

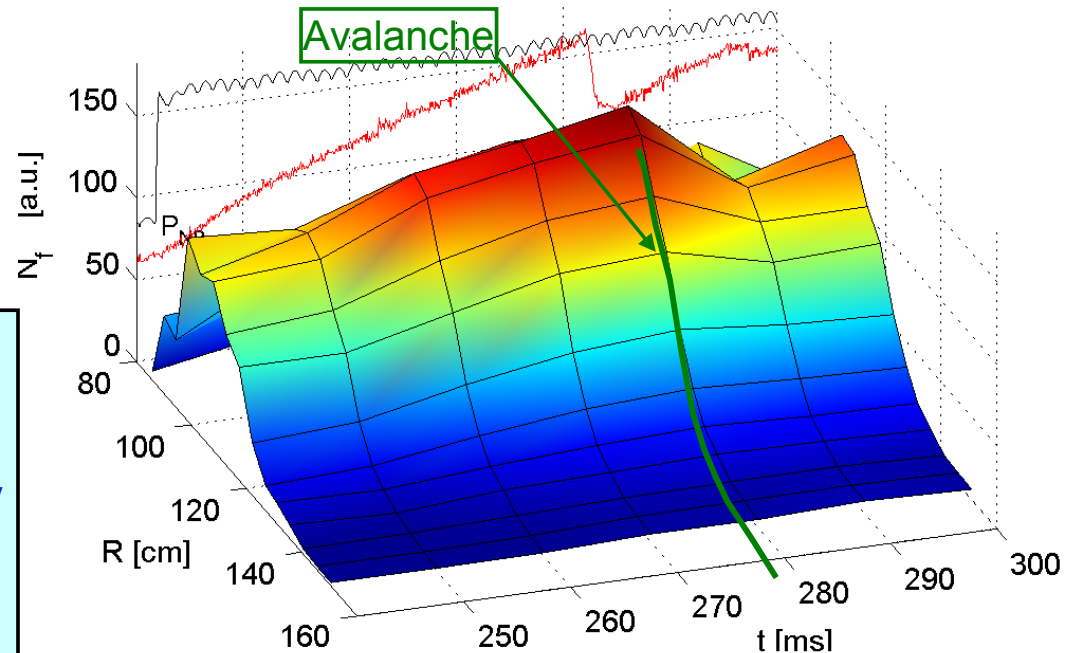

- The UCI FIDA system will be extended to tangential view for slow system in FY 10 and fast system in FY 11.
- The tangential system will provide crucial velocity space information particularly relevant for NBI current drive physics.
- A single channel neutron collimator will be installed in FY 10 to provide an additional energetic particle constraint.

M. Podesta, UCI, APS

# Conceptual Design to Retire Technical Risks

## Perform Critical Designs and R&Ds Upfront

- **Reliable, robust CS TF joint design at 1T**

*Present TF joint design*

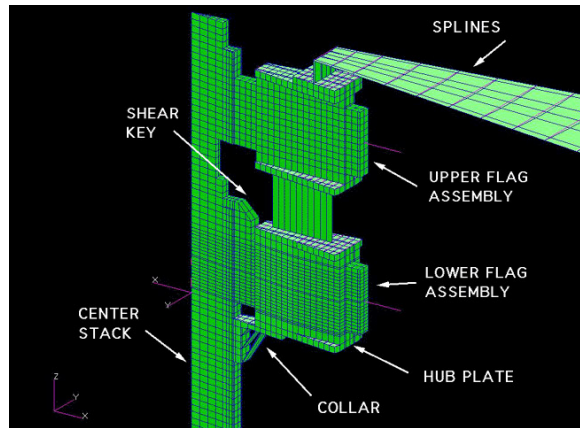

*A candidate new TF joint design*

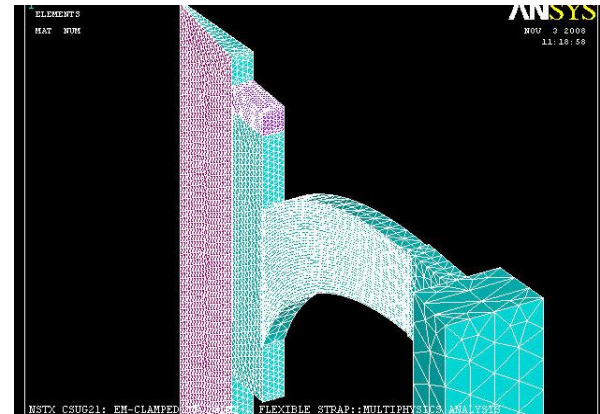

- **Simplification**
- **36 identical turns**
- **Self-closing joints**
- **Possible magnet solution for future STs**

- **Appropriate structures enhancement for 1T, 2 MA operations**
- **NBI beam box tritium decontamination**
  - **Initial decontamination assessment has started in the TFTR Test Cell**