

# Lithium Research Status and Plans

## Charles H. Skinner, PPPL

for the NSTX Research Team

**NSTX PAC-25**  
**Conference Room LSB-B318, PPPL**  
**February 18-20, 2009**

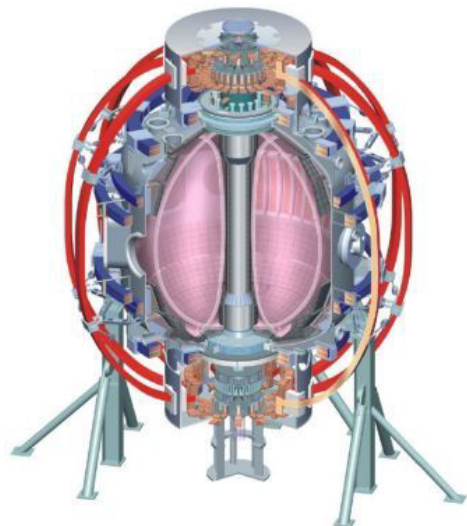

College W&M  
 Colorado Sch Mines  
 Columbia U  
 CompX  
 General Atomics  
 INEL  
 Johns Hopkins U  
 LANL  
 LLNL  
 Lodestar  
 MIT  
 Nova Photonics  
 New York U  
 Old Dominion U  
 ORNL  
 PPPL  
 PSI  
 Princeton U  
 Purdue U  
 SNL  
 Think Tank, Inc.  
 UC Davis  
 UC Irvine  
 UCLA  
 UCSD  
 U Colorado  
 U Illinois  
 U Maryland  
 U Rochester  
 U Washington  
 U Wisconsin

Culham Sci Ctr  
 U St. Andrews  
 York U  
 Chubu U  
 Fukui U  
 Hiroshima U  
 Hyogo U  
 Kyoto U  
 Kyushu U  
 Kyushu Tokai U  
 NIFS  
 Niigata U  
 U Tokyo  
 JAEA  
 Hebrew U  
 Ioffe Inst  
 RRC Kurchatov Inst  
 TRINITI  
 KBSI  
 KAIST  
 POSTECH  
 ASIPP  
 ENEA, Frascati  
 CEA, Cadarache  
 IPP, Jülich  
 IPP, Garching  
 ASCR, Czech Rep  
 U Quebec

# NSTX lithium research is integral part of broad approach to develop lithium as PFC concepts for future machines

LTX lithium handling facility

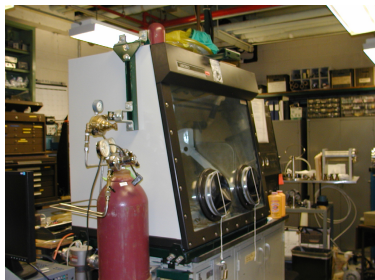

LTX PFC test facility

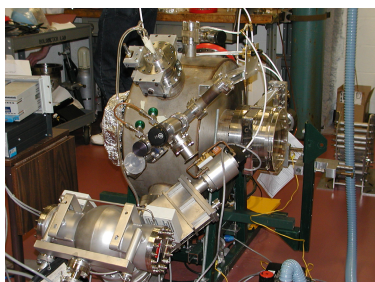

Purdue surface analysis facilities

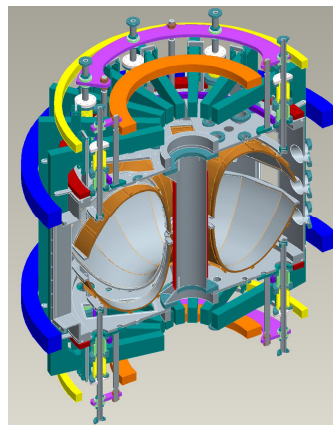

NSTX

- Lithium evaporator
- Liquid lithium divertor
- High performance plasma

NSTX materials analysis probe

LTX

- Fully non-recycling liquid lithium PFCs
- Profile control with core fueling

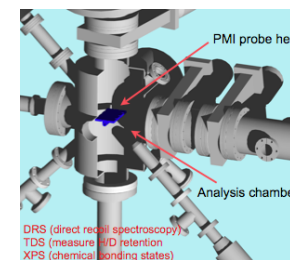
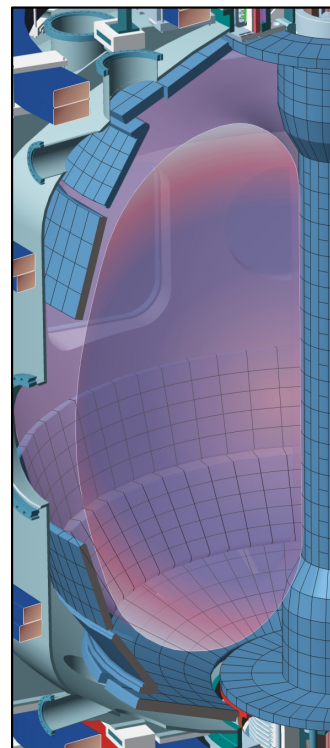

DRS (direct recoil spectroscopy)  
TDS (measure H/D retention)  
XPS (chemical bonding states)

Next Step ST's

Erosion/deposition  
H retention modeling

# Goals of Lithium Research on NSTX:

## Over-arching goal:

Develop and understand novel Li-based PMI solutions for NSTX, NSTX-upgrade design, a high-heat-flux facility, and a low aspect ratio component testing facility (FESAC-TAP)

## Operational Goals:

Implement liquid Li divertor for pumping, and investigate other potential benefits:

- Improved confinement
- Reduction/elimination of ELMs
- Longer-term: steady-state high-heat-flux handling

## Physics Understanding Goals:

- Lithium surface physics and chemistry.
- Relationship between lithiated surface conditions and edge and core plasma.
- Role of carbon-Li interaction by comparison to LTX results (no carbon PFCs).

# Lithium research timeline on NSTX

- Li pellet injection:
  - 2-5 mg pellets, on graphite divertor (2005)
- Li Evaporators:
  - '06-'07 Single LITER: deposition on graphite divertor.
  - '08-'09 Dual LITER: deposition on graphite divertor.
- Li Powder Dropper: (40  $\mu\text{m}$  Li powder)'09...
- Liquid Lithium Divertor [SNL collaboration, synergy with LTX] (2010-2013):
  - LLD-1: Assess pumping capabilities of a liquid lithium divertor PFC using Li evaporated on Mo/SS/Cu baseplate.
  - LLD-2: Achieve density control using modified/upgraded LLD-1 - possibilities: outboard mesh, inboard LLD, enhanced LLD-1 fueling...
  - LLD-3: Long-pulse (5s) high-power handling capability (up to 16MW): capillary surface with active cooling?

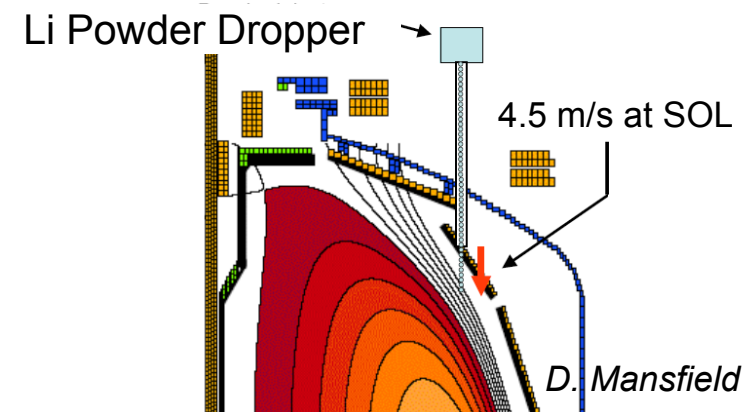
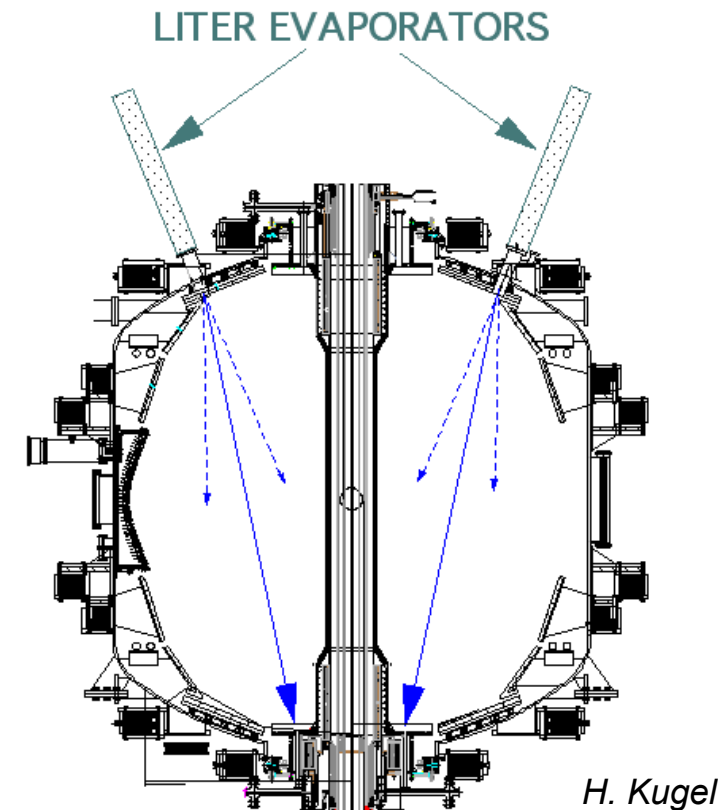

# Overview of how Li changes NSTX high-performance discharges

Standard high  $\kappa \sim 2.3$ ,  $\delta \sim 0.6$  shape

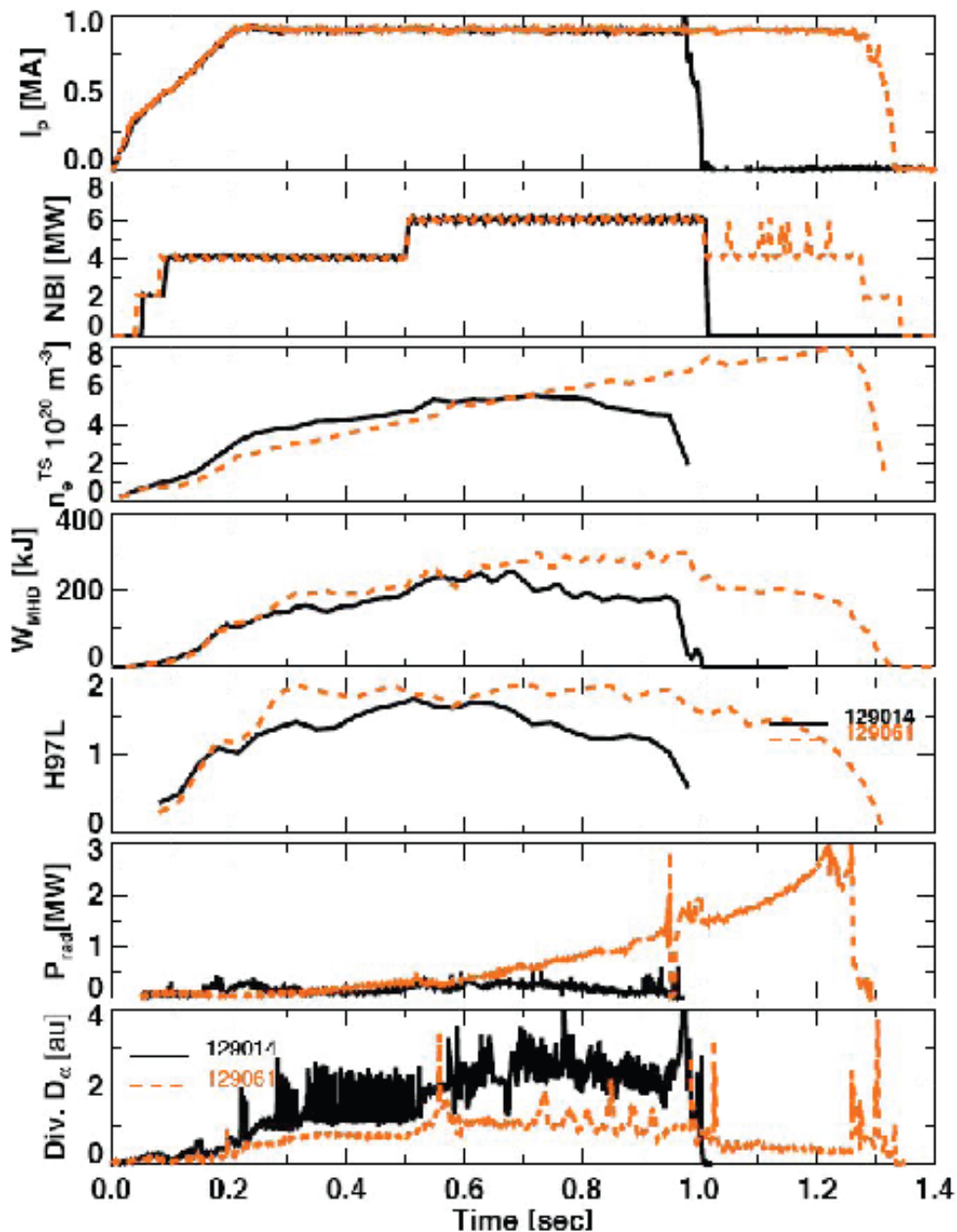
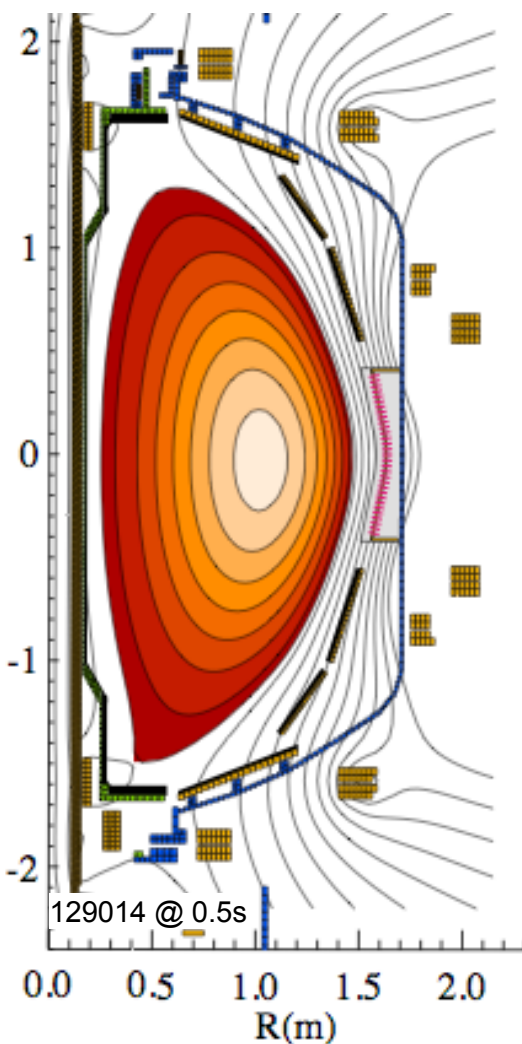

- Pre-Li, **Post-Li**
- **Longer pulse**
- **Lower  $n_e$  early, higher late**
- **Higher stored energy**
- **Higher H-factor**
- **Higher radiated power**
- **ELM-free, lower recycling**

*Kugel PSI08*

# Stored energy increased, and edge stability enhanced (ELMs suppressed) with two LiTER operation in 2008

Stored energy ( $W_{MHD}$ ) increases after Li deposition mostly through increase in electron stored energy ( $W_e$ )

Enhancement of edge stability with lithium. Preliminary stability analysis indicates reduction of edge  $n_e$ ,  $P_e$  gradients responsible for stabilization of ELMs

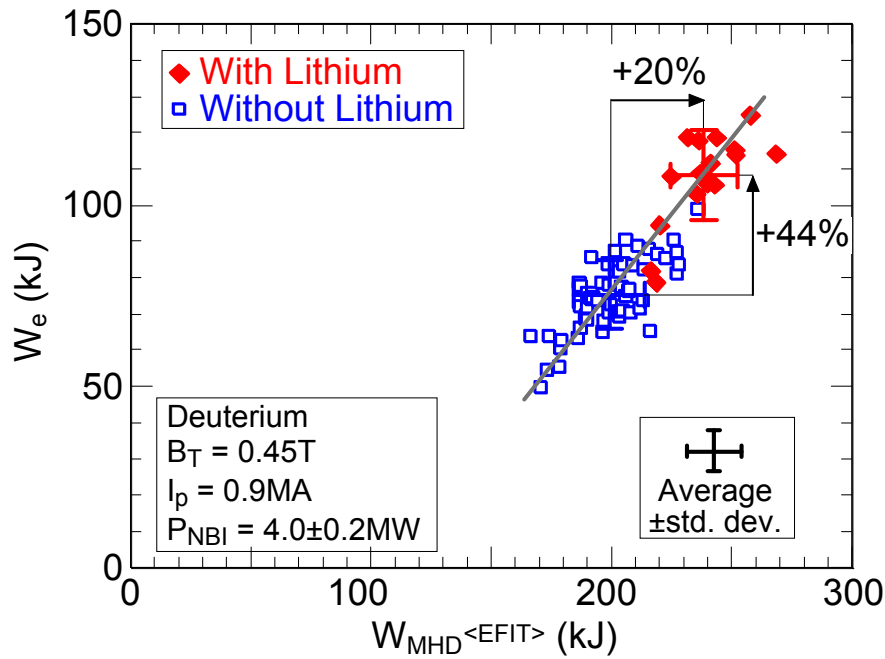

(M.G. Bell)

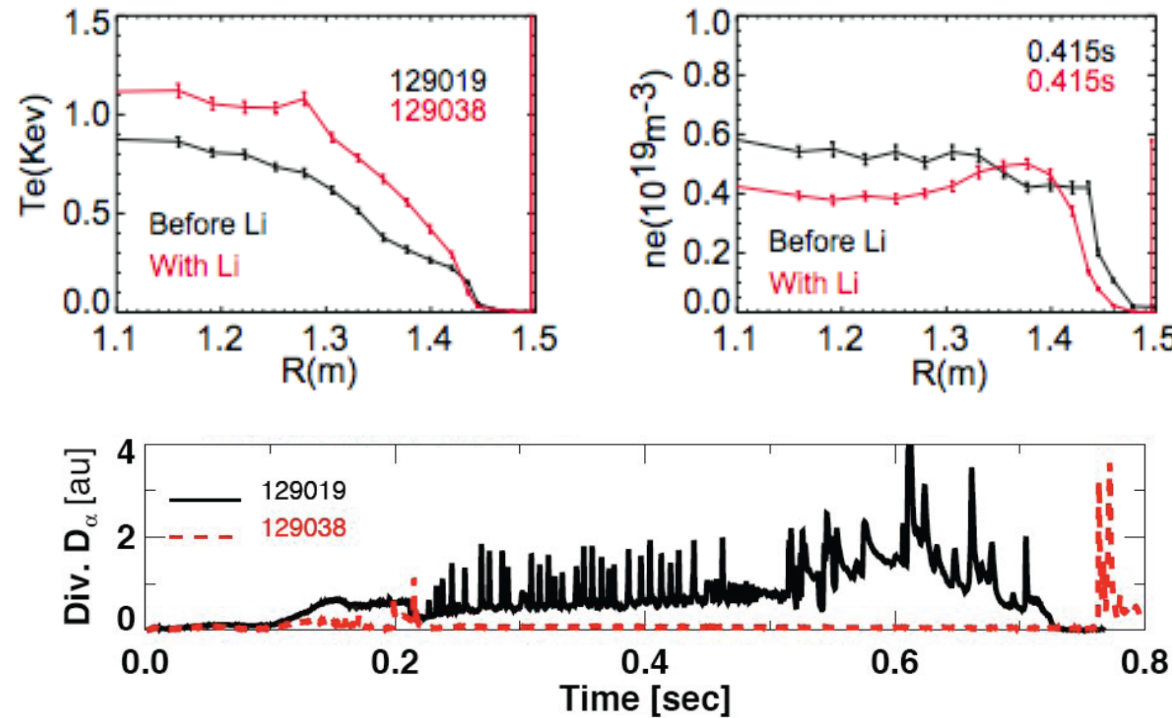

(R. Maingi (ORNL) DPP APS and PAC25 talk)

Also reduced or no intershot He-GDC.

# New Lithium density measurements indicate that carbon remains dominant impurity during LiTER operation

PAC23-6,8

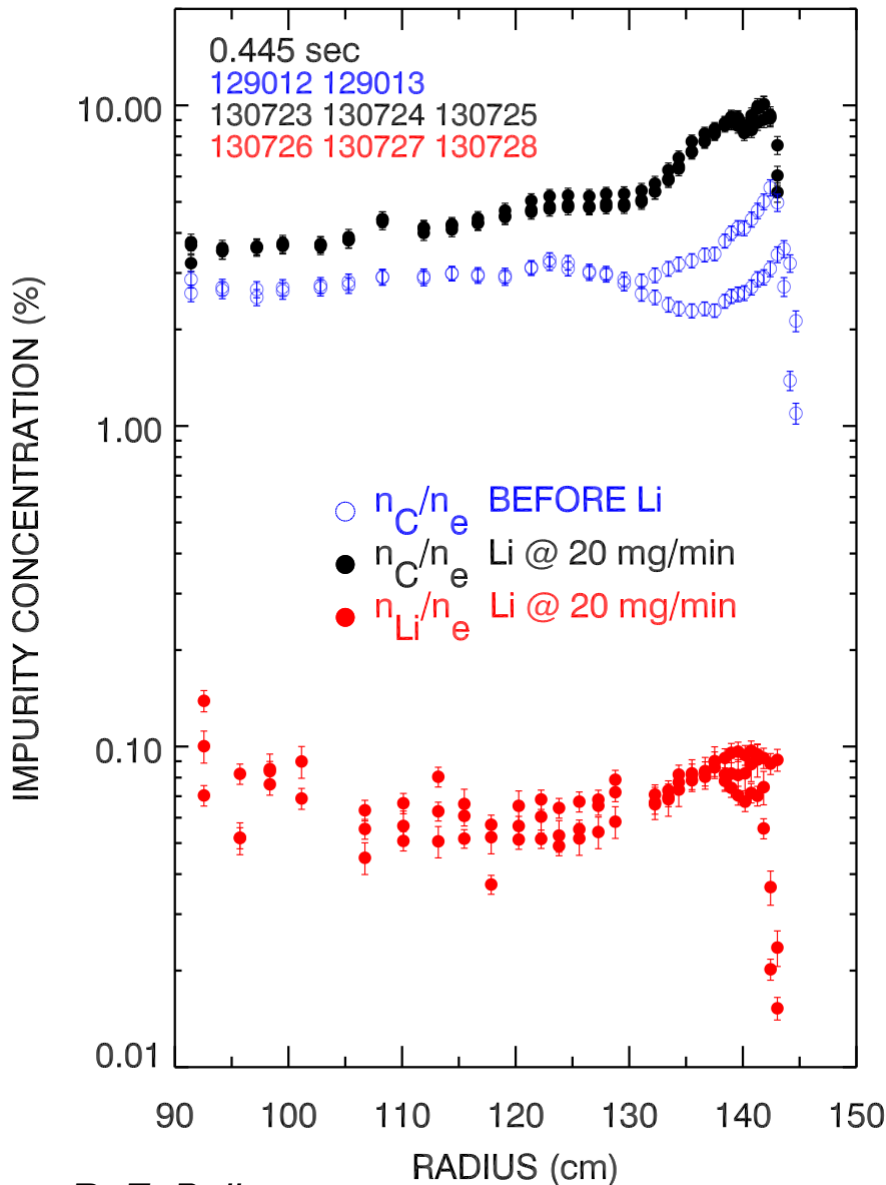

- Impurity density profiles from CHERS
  - C VI,  $n = 8-7$  transition, 529.1 nm
  - Li III,  $n = 7-5$  transition, 516.7 nm
- Lithium concentration much lower than carbon concentration
  - $n_C/n_{Li} \sim 100$
- Carbon increases with Li evaporation
  - perhaps due to ELM stabilization
- Hollow profiles for both C and Li

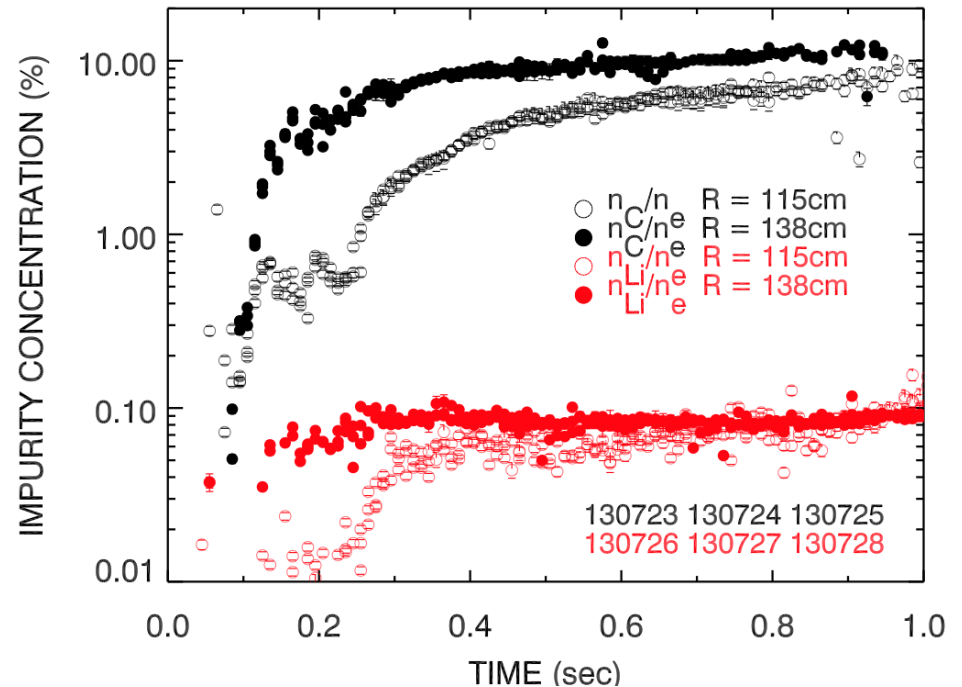

R. E. Bell

# Lithium pumps D - more D fuel required

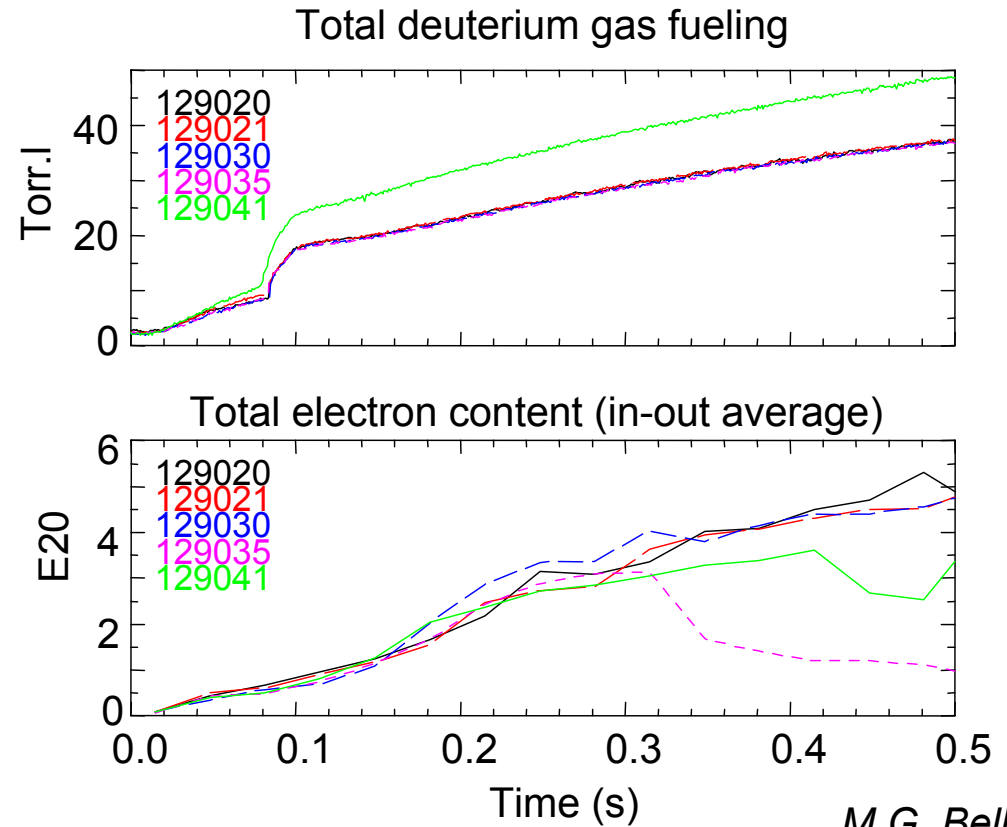
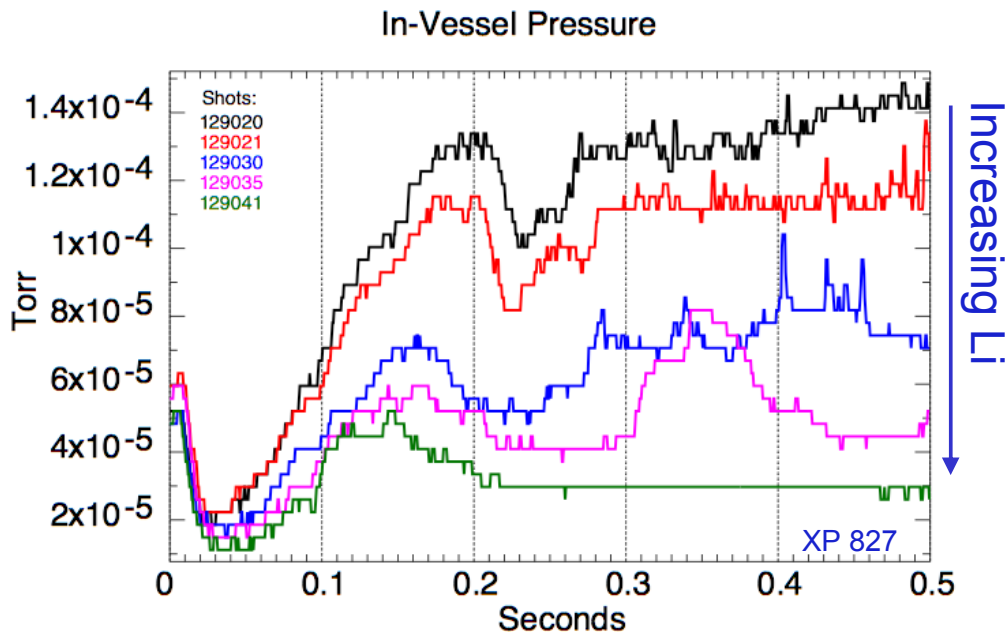

M.G. Bell

- Systematic decrease of in-vessel neutral pressure with increasing Li
- Fueling increased to maintain electron density
- Increase fueling efficiency with supersonic gas injector.
- *LTX comparisons are expected to yield physics insights and guide design of NSTX-U and future STs.*



# Pumping/retention of hydrogenic species with and without Li is highest priority for FY09 research (Joule Milestone)

PAC23-1,7

D retention by Li on PFC surface is believed to be primary cause of plasma improvements.

## FY09 Plan:

1. Particle balance of ohmic/RF shots (Static: valves closed, no pumping)
  - a) Before and with Li, LLD.
  - b) Time dependent data (sec - day)
  - c) Measure D retained / D ion flux
  - d) Quartz Microbalance data.
2. Particle balance of NBI shots (dynamic).
3. Investigate surface physics by analysis of 'fresh' samples using new sample probe (*Purdue collab.*).
4. Modeling (Wall PSI code, Pigarov (UCSD) ).
5. "Joint" retention/fueling studies with LTX.

Coordinated with C-mod and DIII-D.

## FY08 results

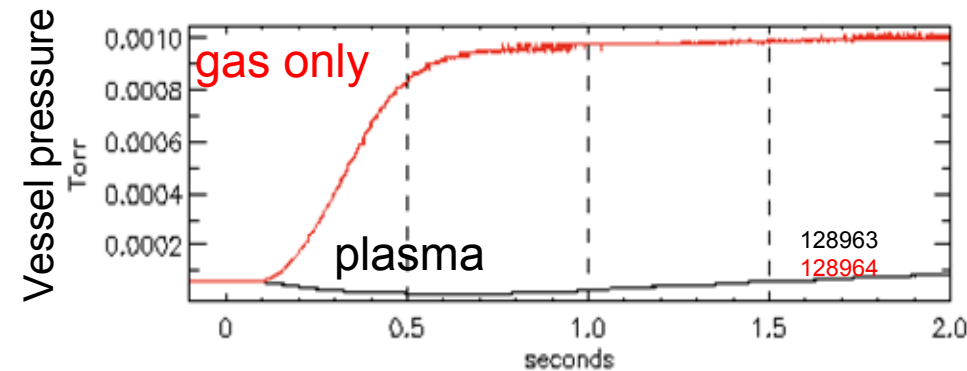

**97-100%** prompt D retention observed in ohmic/RF valves-closed shots before and with-Li

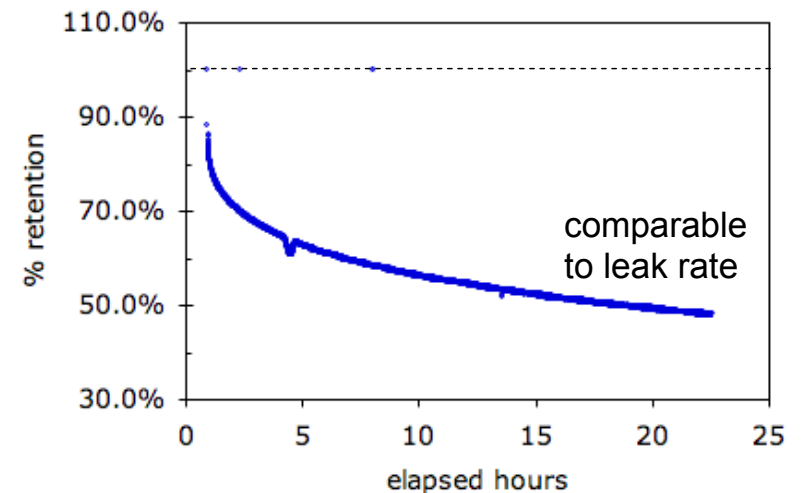

Over 24 h retention, drops to ~ 50% before-Li, 60% with-Li.

C. H. Skinner

# Liquid Lithium Divertor (LLD) to be tested in FY 10

Manufacturing of LLD plates challenging - LLD usage delayed from FY09 to FY10

## Sandia National Lab

(conical shape the copper first, and then braze SS-316 to the conical shaped copper).

PPPL is ready with a backup option to ensure LLD ready for FY10 usage (braze SS-316 on to flat copper and then step-bend to it to the conical shape). Shared Mo plasma spray development with LTX.

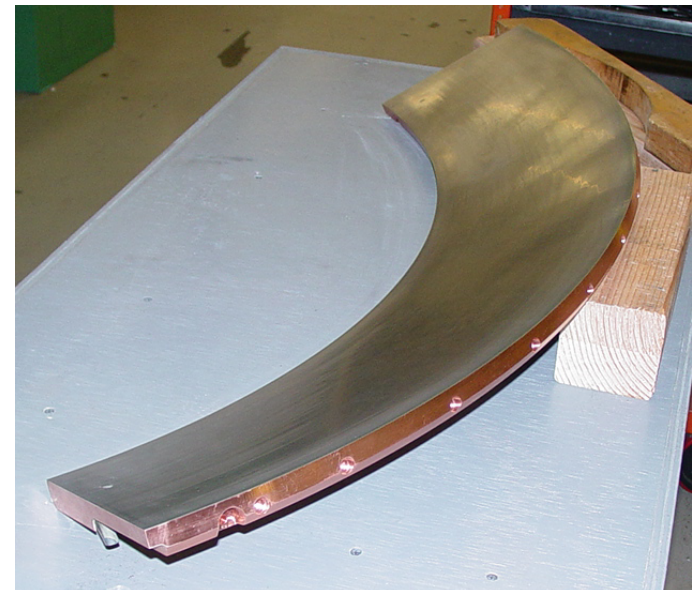
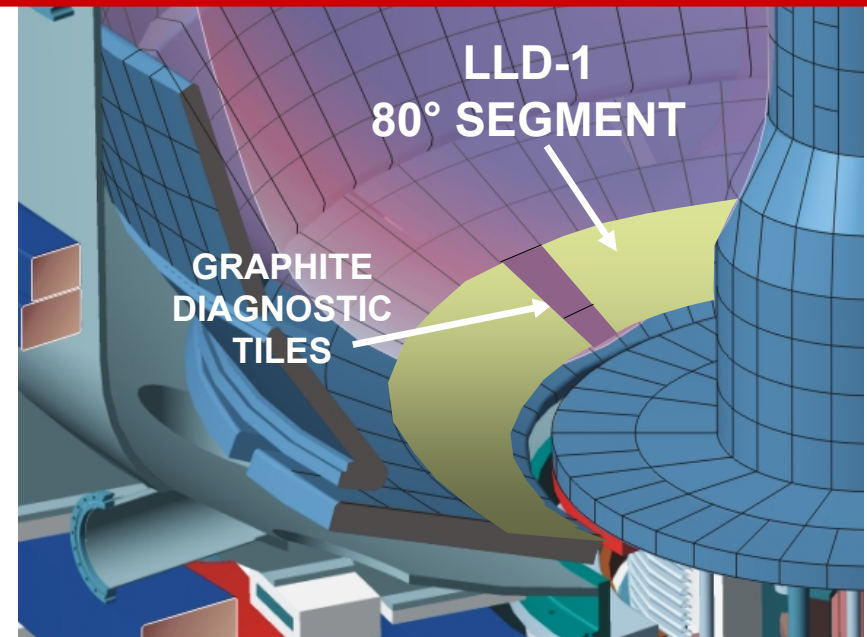

SNL plate after brazing

**LLD to be installed in summer 2009**

# In-situ Surface Analysis of NSTX plasma-exposed surfaces

PAC23-8

Sample Probe aims to address: *“fundamental processes governing particle balance...using lithium surfaces in the divertor...”*

(Joule milestone language)

FY'09 Thermal Desorption Spectroscopy ex-vessel, promptly after plasma exposure (no air exposure).

FY'10 sophisticated ex-vessel surface analysis station (TDS, LEISS, DRS...) for prompt analysis of 'fresh' samples to characterize hydrogen retention and lithium bonding state.

*World leading direct shot-to-shot correlation of an in-situ PMI surface science measurement with plasma performance.*

JP Allain (Purdue)

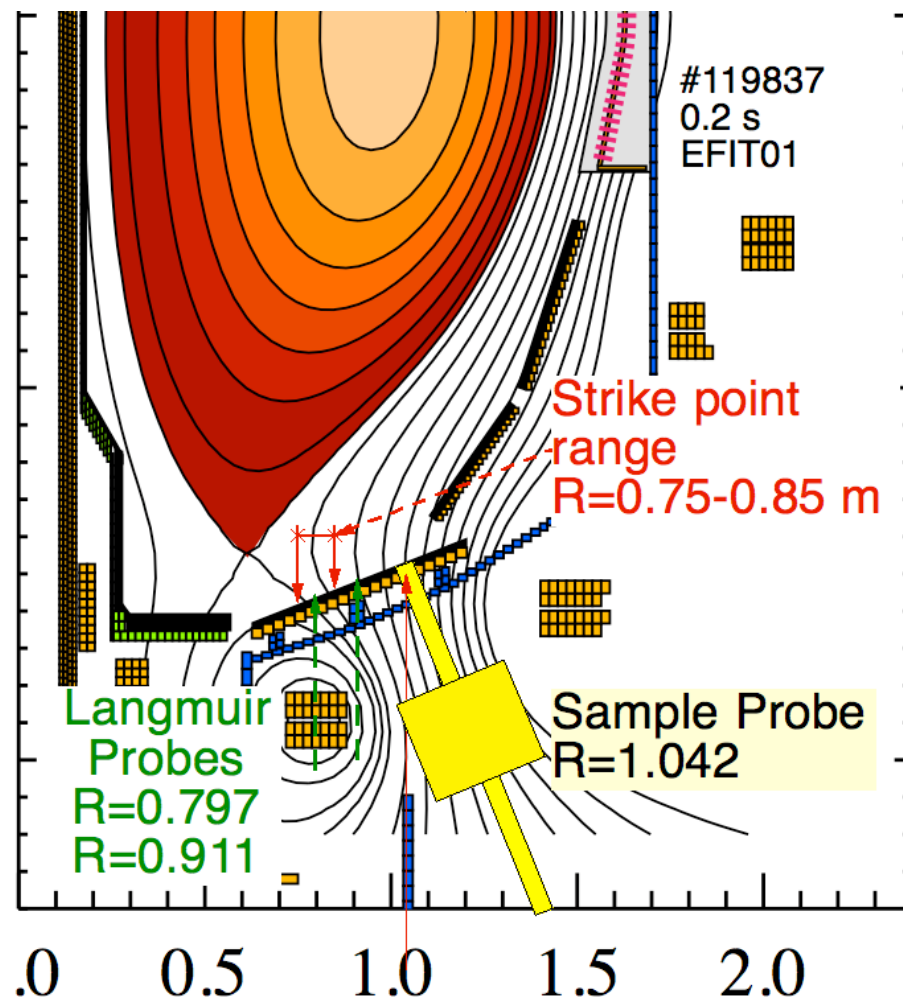

Candidate model discharge  
Plan strike point sweep over fixed Langmuir probes to measure (D retained / D incident)

# Predictive modeling of LLD performance will be compared to experiment in FY10-11

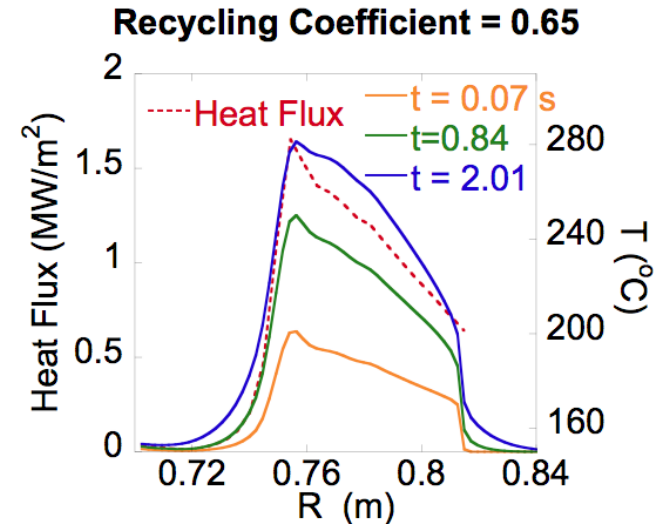
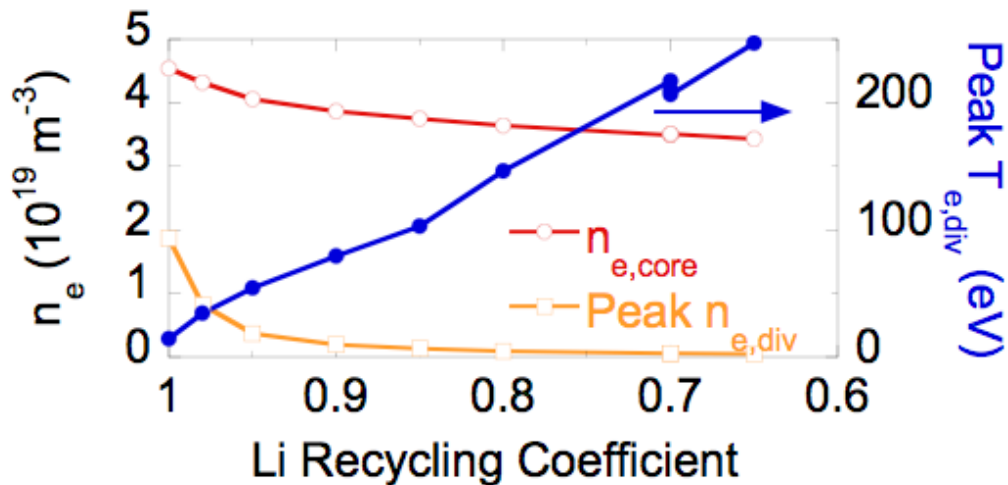

- UEDGE simulation of NSTX shot 128339 with imposed recycling coefficient on outer target (Stotler, Pigarov UCSD),
  - Quantifies associated reduction in core density.
- Heat flux input to heat transfer calculation with 3-D model of LLD (Zakharov),
  - $\Rightarrow$  Predict resulting Li evaporation rate.
- Self consistent predictive simulations of LLD with updated UEDGE (Pigarov (UCSD)),
  - Include Li evaporation, sputtering, and transport in SOL.
  - Preliminary conclusion is that Li is retained in divertor.

# Detailed Modeling of Lithium Behavior in NSTX is Expanding

PAC23-8

- Continued UEDGE simulations of Li migration & penetration into core, as well as D retention in Li (Pigarov (UCSD)).
- Simple estimate of global recycling coefficient via DEGAS 2 using available experimental data (Stotler).
- Erosion / redeposition modeling of lithium in Purdue laboratory experiments and NSTX (Brooks & Allain (Purdue)),
- Effect of ELMs & disruptions on liquid Li (Hassanein (Purdue)).
- Probe data from LLD diagnostic module will substantially enhance input data for modeling.

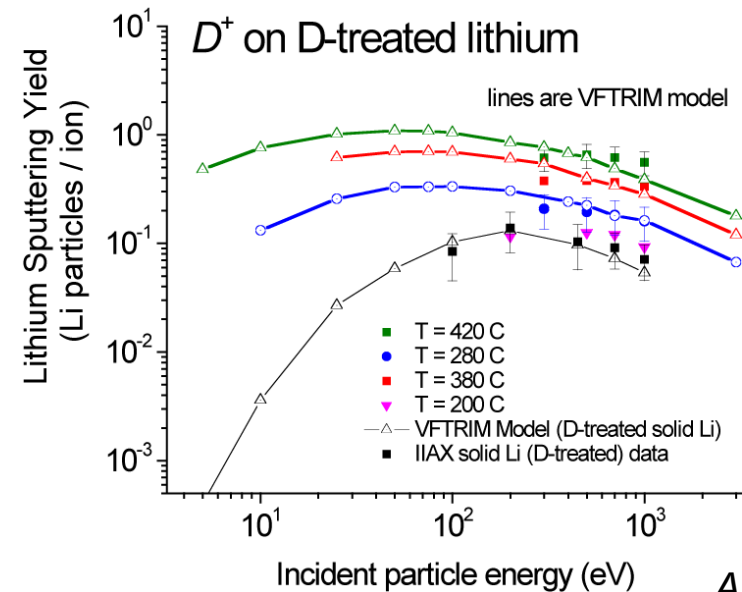

Allain, Purdue

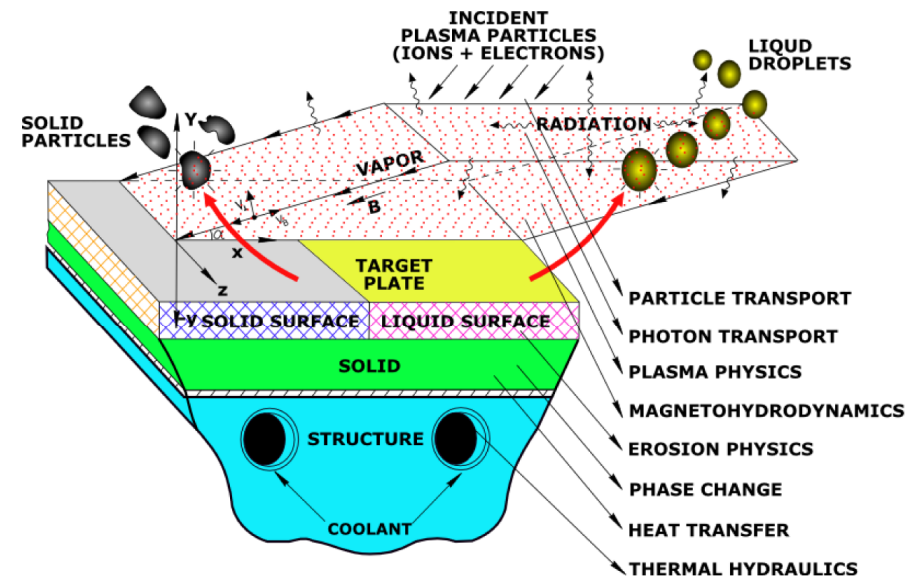

Hassanein, Purdue

# Diagnostic upgrades support LLD research

PAC23-8

## FY2009

- Li CHERS.  
to measure Li transport to plasma core.
- Fast IR Camera.  
to characterize ELM interactions.
- Divertor bolometer upgrade.

## FY2010

- LLD Diagnostic Tile Sensors.  
Graphite tile transition regions between segments contain:
  - multi-Langmuir probe array
  - signal conditioners (Ruzic, UIUC),
  - biased electrodes (test of SOL control)
  - thermocouples
- Lyman- $\alpha$  AXUV diode array.  
recycling measurements with highly-reflective Li.
- Imaging spectrometer.  
to measure D, Li, C sources.

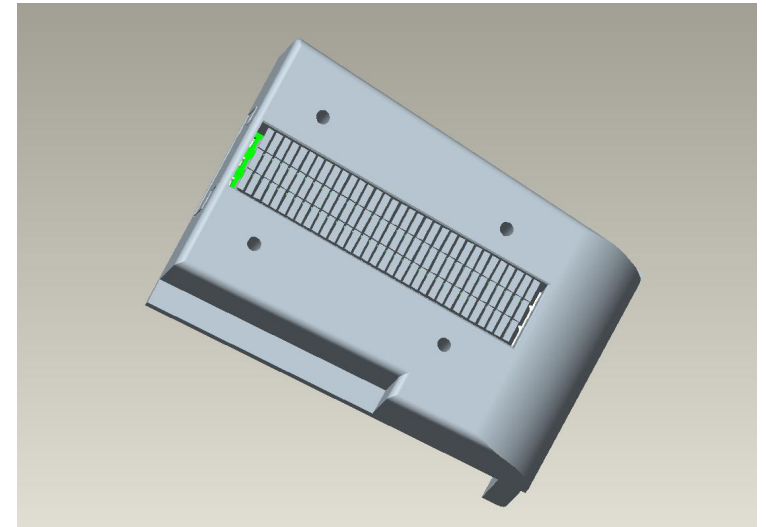

Langmuir probe tile (Thesis research)

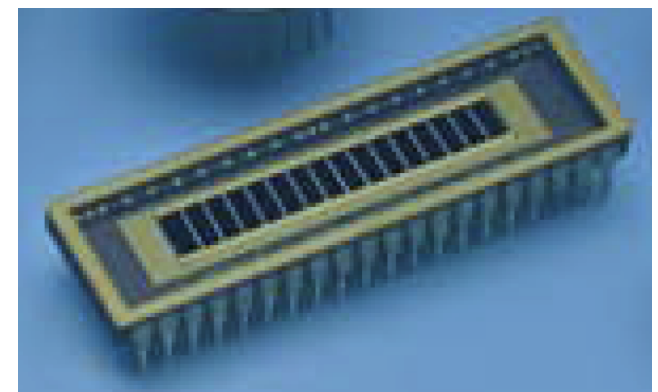

AXUV diode array

# Lithium and fueling program plan

PAC23-1

## 2009-2011

- Perform hydrogen retention and pumping efficiency studies ('09)
- Test Li powder dropper ('09 - encouraging results already in '08).
- Optimize efficiency of conventional and supersonic gas injector fueling ('09 - '10)
- Characterize plate-based Liquid Lithium divertor (LLD) module operation ('10)
- Upgrade LLD based on results ('11)
- Compare LLD results to LTX. LTX aims at fully-nonrecycling liquid lithium PFC's, profile control with core fueling, and flat-temperature "Li-Wall" regime ('09-'011)

*New tools: LLD + diagnostics, upgraded SGI, programmable center stack gas injector, Investigate Li transport with CHERs diagnostic*

## 2012-2013

- Long pulse divertor upgrade for 5 sec. long pulses at 2 MA, 1 T - possibilities:
  - Re-design or upgrade LLD for longer pulse
- Implement core fueling (pellets (ORNL proposal- funding needed), Compact toroids (available for installation '11)

*New tools: Long pulse divertor, pellet inj., CT injector, new divertor diagnostics*

# **Summary:** NSTX has made, and will continue to make, substantial progress in assessing novel Li-based PMI solutions

**Goal:** To assess novel Li-based PMI solutions to support NSTX, NSTX-U, a high heat flux facility, and a low aspect ratio CTF.

- LiTER operation is yielding new insights into Li-based PFCs
- D retention with and without-Li is highest priority for FY09 (2.5 run days). Preliminary results show surprisingly high prompt D retention.
- New sample probe and analysis station will investigate surface physics and chemistry for shot-to-shot correlation with plasma performance.
- LLD investigations begin in FY'10, upgrade (if warranted) in FY'11.
- Modeling effort ramping up, aimed at LLD comparisons.
- NSTX sample probe data and Purdue lab experiments will together challenge erosion & redeposition modeling.
- UEDGE & DEGAS 2 will be used to model D recycling as well as Li erosion and transport.



# Appendix: Response to PAC-23 report (i)

	PAC23 queries and recommendations	Progress and plans
1,3	Formulate additional milestones for 2nd LiTER and LLD	FY09 Joule milestone on retention will address pumping characteristics of Li surfaces using LiTER. FY10 research milestone will assess impact of LLD on edge plasma performance. FY11 BP milestone will utilize new surface analysis diagnostic (MAPP) to analyze surface chemistry in 'real-time'. Imaging Divertor Spectrometer.
2,3	Focus organizational structure on key priorities.	Lithium Research Thrust formed led by Charles Skinner (research plan and diagnostics) and Daren Stotler (modelling)
6.	Are the positive effects on plasma performance and plasma profiles the result of changes in recycling (pumping)?	ELM suppression was correlated to reduction of edge density and increase in edge temperature.
6.	If the Li pumping is the dominant effect, is the important pumping occurring at the divertor or around the first-wall generally?	Ion Beam tile analysis shows campaign integrated D coverage highest in private flux region.
6.	Is it possible that lithium coatings primarily bind deuterium loaded into the carbon wall, making it unavailable for recycling?	Yes - Lab experiments (Sugai) have shown LiH and LiO <sub>2</sub> formation and suppression of physical and chemical sputtering.

# Apendix: Response to PAC-23 report (ii)

	PAC23 queries and recommendations	Progress and plans
6.	<p>Could it be that the positive effects correlating with Li usage are due to suppression of some impurities (e.g. C, O) and/or their replacement with Li in the plasma?</p>	<p>No. CHERS data shows carbon density increases with LiTER operation possibly due to ELM supression. Li density very low (~ 0.1%)</p>
6.	<p>Closer collaborations with FTU, may also provide information on the role of carbon-lithium interactions.</p>	<p>Personnel are in contact and visit in both directions.</p>
7.	<p>Experiments should include particle accounting (i.e., how much gas is injected versus how much is left in the vessel after a shot, as well as postmortem analysis of the tiles). Experiments should be done with bare walls after a vacuum break (no Li on surfaces) and then, after lithium is introduced, for each shot.</p>	<p>Before-Li and with-Li particle accounting performed in '08 and more planned for '09. IBA, XPS...tile analysis published for '07 tiles and in progress for '08 tiles.</p>
8.	<p>More personnel -&gt;  Diagnostics -&gt; Modelling -&gt; Experiments -&gt;</p>	<p>&gt; Hassanein, Allain (collab.) Gray, Jaworski (postdoc), Kallman (PhD thesis). &gt; Li CHERS, sample/MAPP probe... (slide 8). &gt; ORNL pedestal stability analysis (slide 13). &gt; 3-4 run days for retention, LiTER, Li powder dropper FY09.</p>