

Raman spectroscopy of carbon dust samples from NSTX

Y. Raitses^{a,*}, C.H. Skinner^a, F. Jiang^b, T.S. Duffy^b

^a Princeton Plasma Physics Laboratory, Princeton, NJ 08543, USA

^b Department of Geosciences, Princeton University, NJ 08544, USA

Received 13 November 2007; accepted 17 January 2008

Abstract

The Raman spectrum of dust particles exposed to the NSTX plasma is different from the spectrum of unexposed particles scraped from an unused graphite tile. For the unexposed particles, the high energy G-mode peak (Raman shift $\sim 1580\text{ cm}^{-1}$) is much stronger than the defect-induced D-mode peak (Raman shift $\sim 1350\text{ cm}^{-1}$), a pattern that is consistent with Raman spectrum for commercial graphite materials. For dust particles exposed to the plasma, the ratio of G-mode to D-mode peaks is lower and becomes even less than 1. The Raman measurements indicate that the production of carbon dust particles in NSTX involves modifications of the physical and chemical structure of the original graphite material. These modifications are shown to be similar to those measured for carbon deposits from atmospheric pressure helium arc discharge with an ablating anode electrode made from a graphite tile material. We also demonstrate experimentally that heating to 2000–2700 K alone cannot explain the observed structural modifications indicating that they must be due to higher temperatures needed for graphite vaporization, which is followed either by condensation or some plasma-induced processes leading to the formation of more disordered forms of carbon material than the original graphite.

© 2008 Elsevier B.V. All rights reserved.

PACS: 52.40.Hf; 78.30.-j

1. Introduction

Carbonaceous dust is common in tokamaks and its presence in future devices can pose a serious safety issue [1]. Understanding dust formation and the effects of the plasma on the dust and dust on the plasma is important for the development of a safe fusion reactor. There are several possible mechanisms responsible for dust production: (i) evaporation and sublimation of thermally overloaded wall material during disruptions, (ii) spallation and flaking of thin films or redeposited material or films grown intentionally (by boronization or carbonization) or unintentionally due to plasma chemistry on a surface or (iii) by implantation of energetic particles followed by thermal diffusion and sputtering during wall cleaning or conditioning [2–4]. Plasma-induced synthesis of carbon nanostructures in tokamaks has also been reported [5]. It is reasonable to

expect that the different formation mechanisms of carbonaceous dust will leave their signatures in their macro and micro-structures.

Raman spectroscopy is uniquely suited for the diagnosis of the microscopic structure of different forms of carbon. The intensity of D-mode at 1350 cm^{-1} relative to the G-mode at 1580 cm^{-1} increases as one goes from perfect graphite such as stress-annealed pyrolytic graphite through commercial graphite to highly disordered (amorphous) black carbon. This increase is explained by an increase of the amount of unorganized carbon and with a reduction of the graphite crystal size. From X-ray diffraction analysis, it is known that the intensity ratio of D-mode to G-mode scales inversely with crystal size [6]. Previous fusion-related studies of Raman spectra characterized structural modifications of graphite induced by plasma effects, and included irradiation of graphite samples with high energy D+ and He+ ions [7], by sputtering of polycrystalline graphite in argon dc glow discharges [8], and the characterization of dust produced in the Tore Supra

* Corresponding author. Tel.: +1 609 243 2268; fax: +1 609 243 2418.
E-mail address: yraitses@pppl.gov (Y. Raitses).

tokamak [9]. These studies found a strong increase of structural disordering in plasma exposed samples. Ref. [10] compared the hydrogen retention in dust produced in the JT-60 tokamak and in a deuterium arc discharge with graphite electrodes. Arc-produced carbon dust particles were deposited on a molybdenum plate. It was shown that at a deuterium pressure of about 1.6 Pa and plate temperature of 573 K, structural modifications of carbon dust particles produced by the arc were similar to those observed in dust particles from the tokamak. In the present paper, we extend the applicability of these conclusions and provide new supporting evidence in dust from a different fusion device and plasma regimes.

The National Spherical Torus Experiment [11] (NSTX) is aimed at exploring the physics of high beta and high confinement in a low aspect ratio device. Plasma facing components that are in contact with the plasma are protected by a combination of graphite and CFC tiles. The size distribution and composition of dust samples collected from NSTX has been previously reported [12]. Raman spectra contain information on vibrational energies, chemical bonds, molecular symmetry and the physical–chemical environment. In our study, we explore plasma and thermal modifications of the structure of graphite-type dust particles. We compare the Raman spectra of (i) carbon dust from NSTX, (ii) carbon deposits from an atmospheric pressure helium arc discharge and graphite samples, (iii) unexposed to plasma and (iv) heated in vacuum.

2. Experimental setup

The arc setup was designed and built for studying nanotube formation in an arc plasma [13]. It uses a movable graphite anode (0.2–1 cm diameter) and a brass cathode (2.5 cm diameter) (Fig. 1). In the present experiments, the 0.5 cm diameter anode-rod was machined from an unused graphite tile similar to those used on the NSTX. This graphite electrode is mounted on a positioner and the gap between the electrodes adjusted in real time by automated feedback control to maintain a constant arc power (and thereby, arc voltage ~ 20 – 30 V at a arc current ~ 80 A). The arc chamber is evacuated with a rotary pump

to several tens of Pa and then filled to somewhat below atmospheric pressure (60–80 kPa) with helium gas. The arc operates in anodic regime [14], where the anode has a higher temperature than the cathode. The high temperature of the anode causes vaporization of the anode material (graphite) and this sustains steady state arc operation. The plasma in this discharge consists essentially of carbon ions because helium is not well ionized in this relatively low voltage discharge. Carbon ions, atoms and clusters reaching the brass cathode form a deposit (soot).

In addition to plasma arc experiments, we used the same unused tile to prepare small graphite samples which were then heated in a high vacuum furnace to about 2000 K for 1 h under vacuum (< 2 mPa). In another set of heating experiments, the arc apparatus was used to ohmically heat graphite samples to about 2300 K under vacuum or helium atmosphere without a plasma. For that purpose, the graphite anode was brought into physical contact with the brass cathode. The current of 80 A was then supplied through the electrodes for approximately 5 min. The voltage drop across the electrodes was 12 V. The temperature of the graphite electrode was measured with an optical pyrometer (Leeds & Northrup Model 8630).

To measure the Raman spectra we used a micro-Raman system consisting of an air-cooled argon 200 mW ion laser, holographic optics, 0.5-m spectrometer and liquid nitrogen cooled CCD detector (1100×330 pixels) [15]. Through all experiments described in this paper, the laser power was kept very low at about 3 mW. We found that this power level is insufficient to induce appreciable structural modifications of carbon dust samples during the Raman measurements.

3. Raman spectra

Spectral measurements were conducted for several dust samples from each experimental case (NSTX, arc, heating, and an unused tile). Fig. 2 shows some of these samples. In addition, for relatively large samples, a Raman spectrum was obtained at different locations on the same sample. This procedure allowed us to make a reliable qualitative comparison of structural modifications for differently obtained and treated dust particles.

Fig. 3 shows the Raman spectrum of a sample scraped from an unused NSTX tile. Note the prominent G-mode peak at 1580 cm^{-1} and D-mode at 1350 cm^{-1} . The D and G-modes have a relative intensity $I_D/I_G < 1$, indicating that these graphitic materials have a certain degree of disordering. If we compare Raman spectra of dust samples scraped from an unused graphite tile with dust particles found in post-run NSTX samples, we can see that the relative intensity of D-mode increases implying that disordering increases with plasma exposure. Fig. 4 shows three examples of Raman spectra from particles exposed to NSTX plasmas. Fig. 4(b) and (c) shows stronger modifications to the Raman spectra with the ratio of the peaks increasing from $I_D/I_G \sim 0.4$ to $I_D/I_G \sim 1.5$ similar to Tore Supra

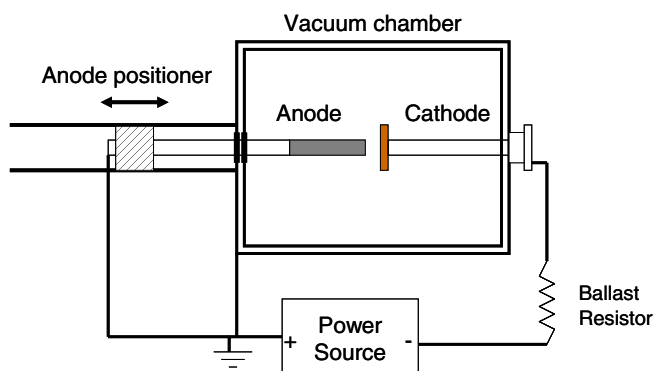

Fig. 1. Atmospheric pressure helium arc.

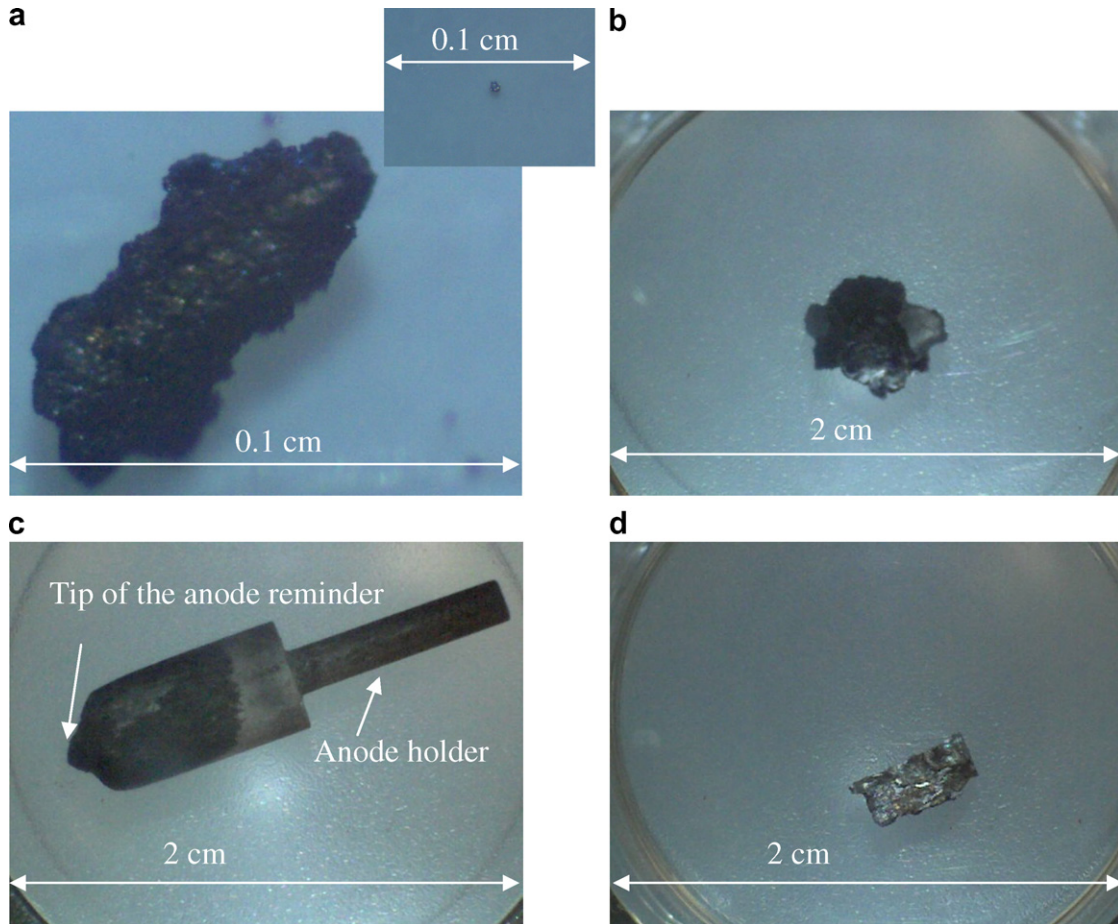

Fig. 2. Photographs of test samples studied with Raman spectroscopy: (a) NSTX flake and dust particles; (b) carbon soot deposited on the arc cathode; (c) post-arc remainder of the graphite anode; (d) a graphite sample heated to about 2000 K in a vacuum furnace. The latter two samples were obtained from an unused graphite tile.

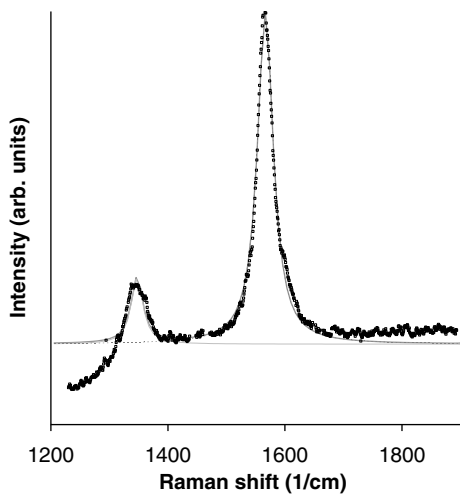

Fig. 3. Raman spectrum of a sample scraped from an unused NSTX tile. Note the prominent G-mode peak at 1580 cm^{-1} and D-mode at 1350 cm^{-1} .

results [9] where such a strong disordering was attributed to nano-porosity. According to Ref. [16] for particles with grain size of larger than 2 nm, the grain size scales inversely

proportional to I_D/I_G [6]: $I_D/I_G = C/La$, where La is the grain size, and $C = 44\text{ \AA}$ for a wavelength of 514.5 nm . Using this relationship, we calculate that the unused tile has a grain size of 20 nm, while dust exposed to the NSTX plasma has a grain size of 10 nm and smaller.

In the arc operation, the anode is heated by the plasma to sufficiently high temperatures for the vaporization of the graphite electrode to occur. The carbon vapor can then undergo different phase and state modifications including ionization, clustering, condensation etc. These carbon particles can deposit as soot on the brass cathode. After operating the arc for 1–2 min, it is left in a helium atmosphere for 2 h to cool down to room temperature to prevent oxidation of the electrodes and soot. Fig. 5 shows the Raman spectra of the arc electrodes and carbon deposits after arc operation. The spectra show that carbon soot deposited on the cathode (Fig. 5(a)) has undergone qualitatively similar structural modifications from the original graphite (Fig. 3) as did the dust particles exposed to the NSTX plasma (Fig. 4). In contrast, the Raman spectrum of a sample taken from a tip of the remainder of the anode is different from both unused tile (Fig. 3) and the cathode soot (Fig. 5(a)). However, when a thin layer was removed

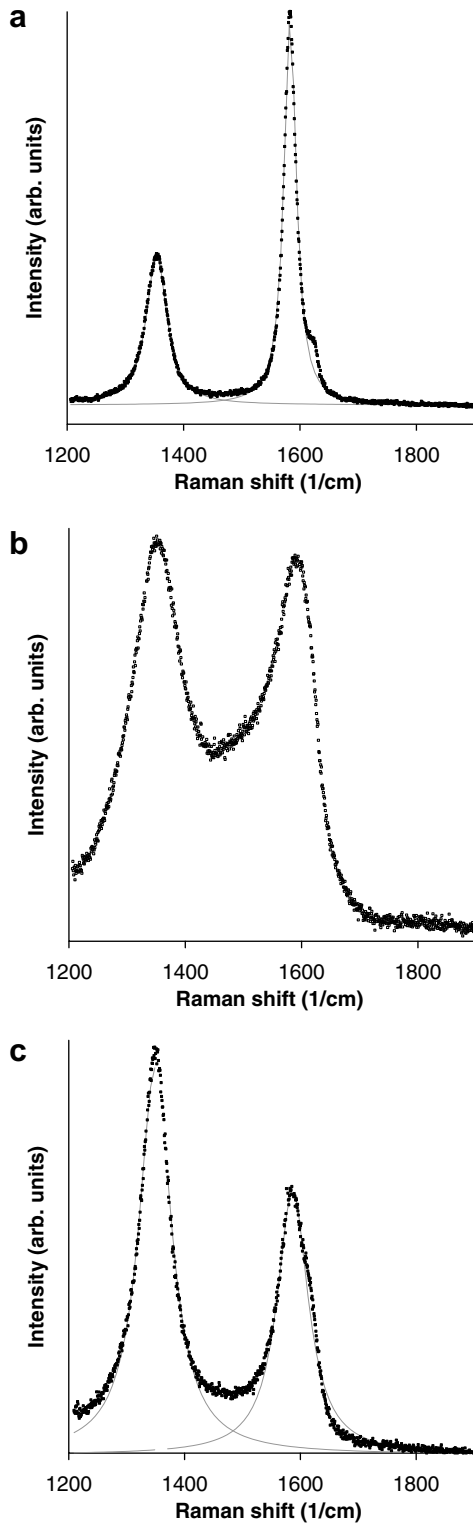

Fig. 4. Raman spectra of particles exposed to NSTX plasmas. The ratio of the peaks is (a) $I_D/I_G \sim 0.4$; (b) $I_D/I_G \sim 1.1$; (c) $I_D/I_G \sim 1.5$.

from this tip, its Raman spectrum (Fig. 5(c)) exhibits a much stronger graphitic order than this surface layer.

Note that during the arc operation the anode tip is at the high temperature (>3000 K [14,17]), which is needed to sustain evaporation of graphite. We measured the anode

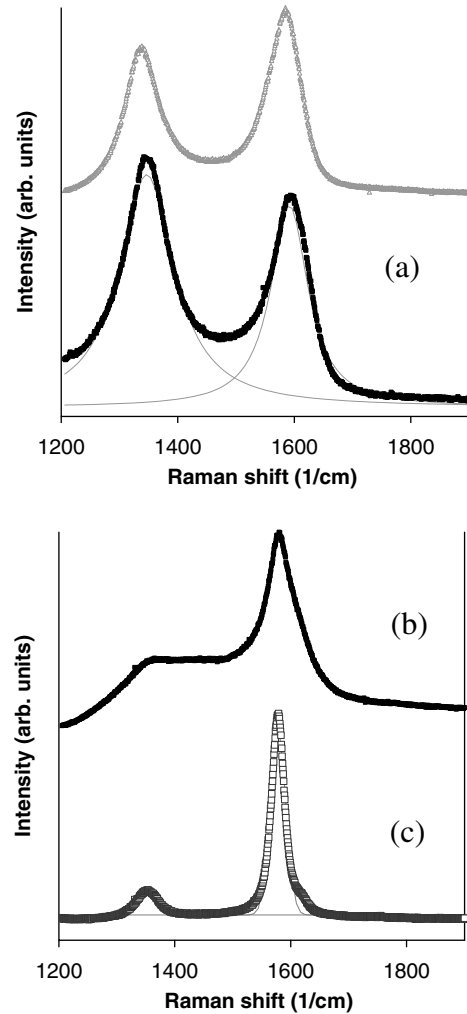

Fig. 5. Raman spectra of carbon samples after arc operation: (a) at different locations of the carbon soot deposited on the copper cathode. A post-arc leftover of graphite anode (b) as it was after arc operation and (c) after scraping of a thin exterior layer from the leftover.

temperature of above 2700 K at the remote location of about several millimeters from the hottest area of the anode tip. The fact that in our experiments, the thermal effects alone do not lead to a strong disordering of the graphite structure at temperatures insufficient for vaporization is supported by Raman measurements of the graphite samples used in vacuum furnace (about 2000 K), which are shown in Fig. 6, and ohmic heating (about 2300 K) experiments. The peak intensity ratio of their spectra, I_D/I_G , remains much smaller than unity before and after heat treatment.

4. Conclusions

Raman measurements of samples in both arc and heating experiments show that strong structural modifications of some NSTX dust particles are due to plasma-induced processes. These processes affect disordering in the graphite structure, which is associated with at least twofold

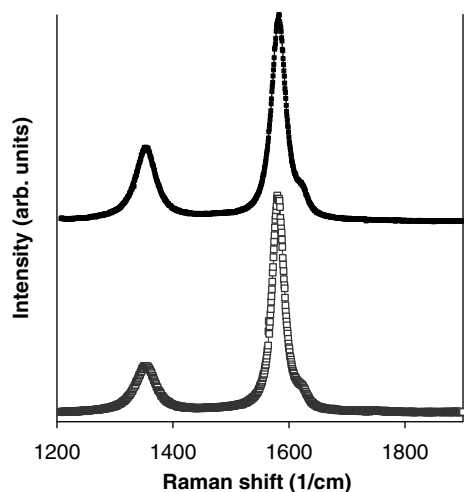

Fig. 6. Illustrative examples of Raman spectrum of a graphite sample heated to the temperature of about 2000 K in the vacuum furnace (<2 mPa). Measurements were taken at different location spots of the same sample.

reduction of the crystal grain size. The structural modifications of NSTX dust are similar to those induced by the arc plasma on carbon particles, which are vaporized from the graphite anode and then deposited onto the cathode. The double peaked shape of the Raman spectrum of the NSTX dust and post-arc cathode soot is similar to the results from Tore Supra [9], which were attributed to high porosity of the dust samples. Note this spectral shape is also found in standard forms of graphite, including highly disordered carbon black [18], and less disordered microcrystalline graphite and glassy carbon [18,19]. It has been recently suggested that the latter material, which is produced by a heat treatment of carbon-contained resins, has a fullerene-related structure [20]. A more detailed study, including analysis of width of the spectral peaks, higher resolution of Raman measurements etc is required to investigate these structural similarities and to determine a more precise structure of the dust particles. For example, unlike highly disordered carbon black, glassy carbon, microcrystalline graphite and carbon nanowalls have an additional peak at 1620 cm^{-1} [18]. This peak, which is typically much weaker than D and G peaks, was not resolved in the present measurements.

Another important result of this study is that heating alone to 2000–2700 K cannot by itself explain the differences seen between the Raman spectra of particles from an unused graphite tile and the plasma exposed NSTX dust. This result indicates that the observed structural modifications must be due to either higher temperatures needed for graphite vaporization or other ablation process,

which is followed either by condensation or some plasma-induced processes or synthesis leading to the formation of more disordered forms of carbon material than the original graphite. For example, for the arc discharge, such high temperatures of the graphite anode are achieved due to high electron thermal fluxes from the arc plasma, while for the NSTX, they might be associated with plasma disruption processes. Moreover, because we found similar plasma-induced structural modifications in dust particles exposed under the different background gases (hydrogen and helium) and the different plasma conditions of the arc and NSTX experiments, our results suggest that the observed structural modifications are unrelated to hydrocarbon compositions on the dust surface or implantation or thermal diffusion. We note, however, that the present analysis technique does not address the potential influence of gas captured or trapped before, during or after the structure formation.

Acknowledgements

The authors would like to thank Angus Pacala for his assistance in arc experiments and Raman measurements. The authors gratefully acknowledge Professor Robert J. Cava of Princeton University for the use of high vacuum furnace for heat treatment of graphite samples in his laboratory, and Tyrel McQueen for conducting this heat treatment. This work was partially supported by US DOE Grant No. DE-AC02-76CH03073.

References

- [1] G. Federici et al., Nucl. Fus. 41 (2001) 1967.
- [2] J. Winter, Plasma Phys. Control. Fus. 40 (1998) 1201.
- [3] M. Rubel et al., Nucl. Fus. 41 (2001) 1087.
- [4] C.H. Skinner et al., Fus. Sci. Technol. 45 (2004) 11.
- [5] Ph. Chappuis et al., J. Nucl. Mater. 290&291 (2001) 245.
- [6] F. Tuinstra, J.L. Koenig, J. Chem. Phys. 53 (1970) 1126.
- [7] K. Niwase et al., J. Nucl. Mater. 179–181 (1991) 214.
- [8] C. Arnas et al., J. Nucl. Mater. 337–339 (2006) 69.
- [9] P. Roubin et al., J. Nucl. Mater. 337–339 (2005) 990.
- [10] H. Yoshida et al., J. Nucl. Mater. 337–339 (2005) 604.
- [11] J.E. Menard, M.G. Bell, R.E. Bell, et al., Nucl. Fus. 47 (2007) S645.
- [12] J.P. Sharpe et al., J. Nucl. Mater. 337–339 (2005) 1000.
- [13] A. Fetterman, Y. Raiteses, M. Keidar, PPPL Report-4288, Princeton, NJ, February 2008.
- [14] M. Keidar, A.M. Waas, Y. Raiteses, E.I. Waldorff, J. Nanosci. Nanotechnol. 6 (2006) 1309.
- [15] S.-H. Shim, T.S. Duffy, Am. Mineral. 87 (2002) 318.
- [16] A.C. Ferrari, J. Robertson, Phys. Rev. B 61 (2000) 14095.
- [17] Yu.P. Raizer, Gas Discharge Physics, Springer, Berlin, 1997, p. 250.
- [18] S. Kurita et al., J. Appl. Phys. 97 (2005) 104320.
- [19] R.J. Nemanich, S.A. Solin, Phys. Rev. B 20 (1979) 392.
- [20] P.J.F. Harris, Philos. Mag. 84 (2004) 3159.