

XPnnn Dust mobilization from ITER-scale castellations (0.5d)

C. H. Skinner, S. Gerhart, L. Roquemore

Motivation:

- Dust on ITER will fall down the gaps between castellations.
- The question is whether it is then permanently 'buried' or could be mobilized by a disruption.
- If the latter it needs to be included in the dust inventory in safety assessments and could contaminate the next plasma.
- The idea is to make up a graphite castellation mockup with gaps that are the same dimensions as the ITER castellations.
- Load it with dust and mount it on the sample probe.
- Insert it and run some VDEs that land close by and see if it mobilizes the dust.
- Weigh the dust before and after, look with fast cameras and spectroscopically.
- The dust could be carbon initially and tungsten late in the run.

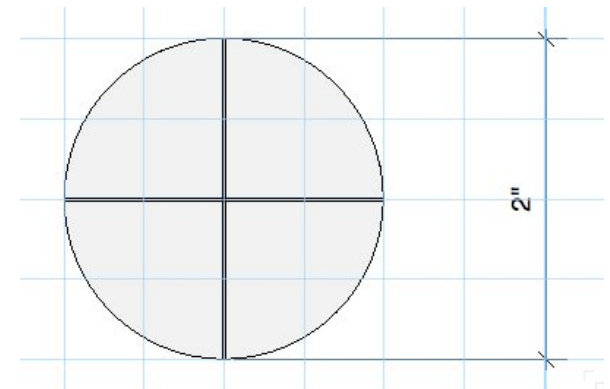

View of top of sample probe with 0.5 mm wide gaps in 'castellations' at depth of gap 15 mm 'carbon' and 8 mm tungsten

Potential dust locations in ITER

Dust typically accumulates at the bottom of a tokamak (TFTR diagnostic pipes, JET subdivertor...).

- Gaps between blanket modules
 - Gaps between tile castellations
 - Under divertor dome
 - Under divertor cassette
-
- Could be carbon, tungsten, beryllium or mixed materials.
 - 'Dust' is defined as particles $< 100 \mu\text{m}$ (larger particles will not transport to the environment in accident scenarios).
 - Typical count median diameter in present tokamaks is few microns.
 - Fractal-nanoscale particles reported in ELM simulators.

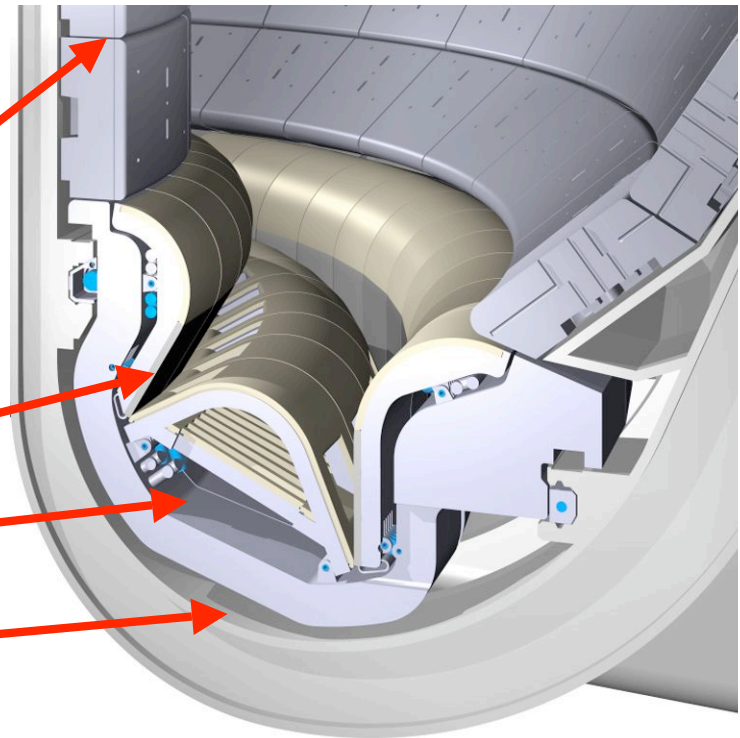

Macrobrush

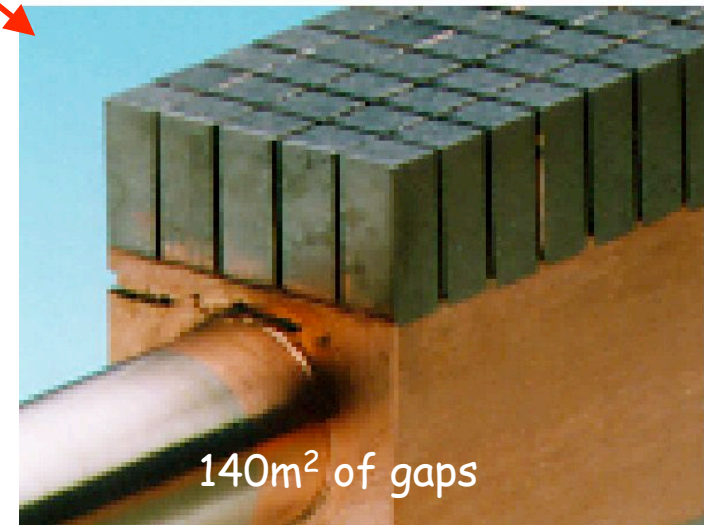

ITER dust management

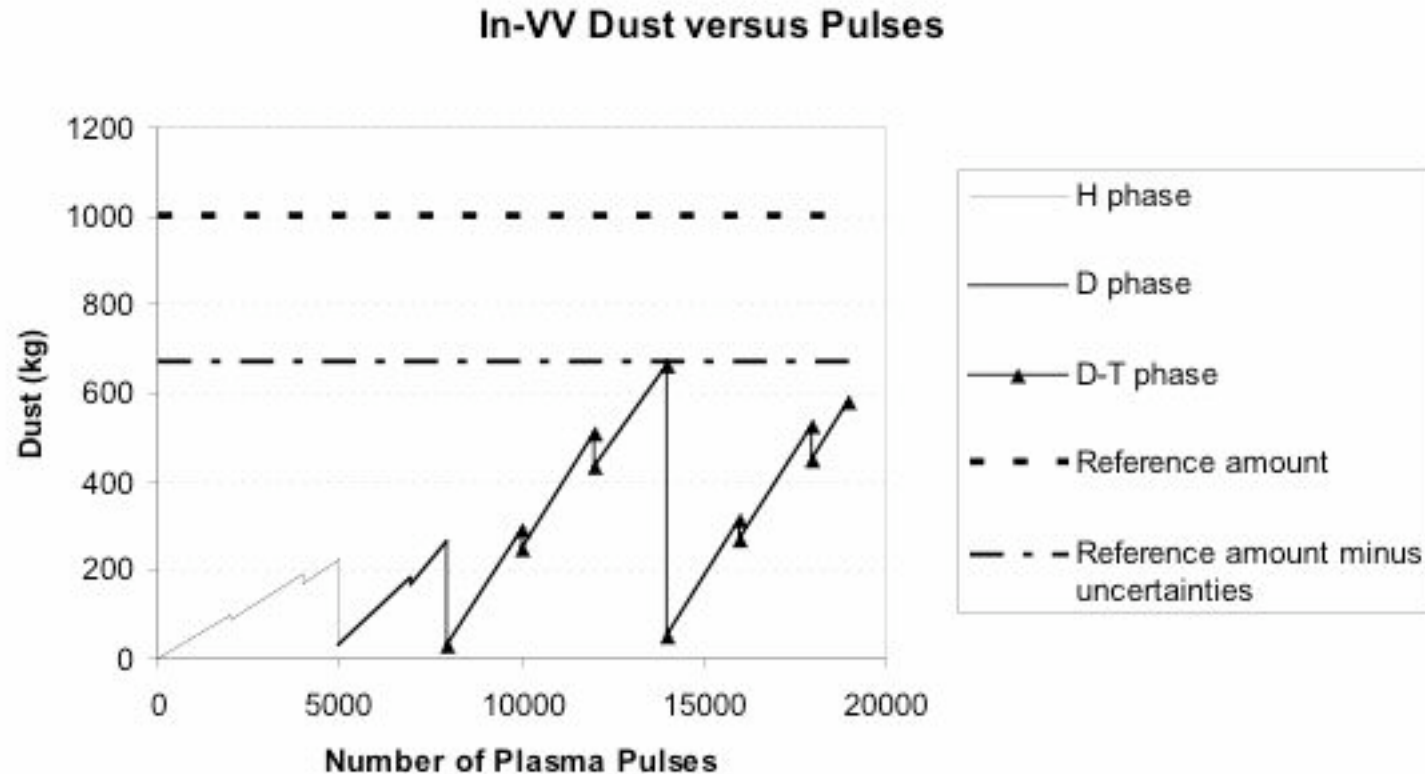

Ciattaglia, SOFT conference 2008 “An integrated approach to in-vacuum vessel dust and tritium inventory control in ITER”

Tungsten spectroscopy:

Tungsten transport is of interest for ITER. Time-resolved measurements of the tungsten charge balance give information on how quickly into the plasmas the ions penetrate.

The tungsten spectra and time evolution on NSTX would be studied using two high-resolution grazing-incidence instruments: the XEUS soft x-ray spectrometer and the LoWEUS EUV spectrometer. For these experiments, XEUS will cover the 8 – 50 Å range and LoWEUS will be set to cover the 30 – 170 Å range.

(Peter Beiersdorfer)

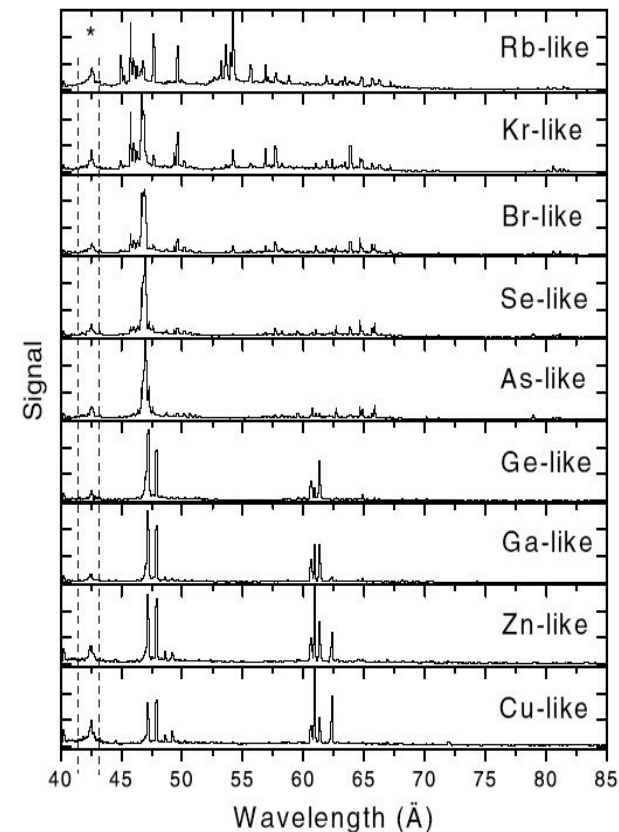

Fig. 3 Tungsten emission observed with the XEUS grating spectrometer [Utter et al. CJP 80 1503(2002)].

Shot List:

Step 1: Reload shot 132855. This is a combined PF-2/PF-1a shot. Convert from He to D₂, and inject Scr. A from 100 msec till 1 sec. Example LFS D2 waveform can be found in shot 129512, though be careful that this is from 2008.

Step 2: Repeat, with vertical control freeze. Freeze the PF-3 voltage from 260-360, and apply a 40 V offset. The discharge should develop a downward VDE.

Step 3: Repeat with Src. B at 0.14 sec, for a total of 4MW

Step 4: Repeat once the best shot from Steps 2 or 3.

Step 5: Reload shape category from shot 129848. This is a similar L-mode shot to what is used above, but with more current in the PF-2 coils, so that the triangularity is reduced. This tends to move the VDE impact point to larger radius. Keep the voltage freeze and offset.

If this discharge has issues, try once to fix it.

Step 6: Repeat twice more the best discharge taken from those above.

There would be intershot He-GDC (Lithium conditioning would not be used as it is not planned for ITER).

A separate test of the weight loss due to the 30 min morning He-GDC would be made.

Also 'dry runs' - loading/unloading the dust without plasma exposure to establish no dust was lost during handling.

Model discharge 132855

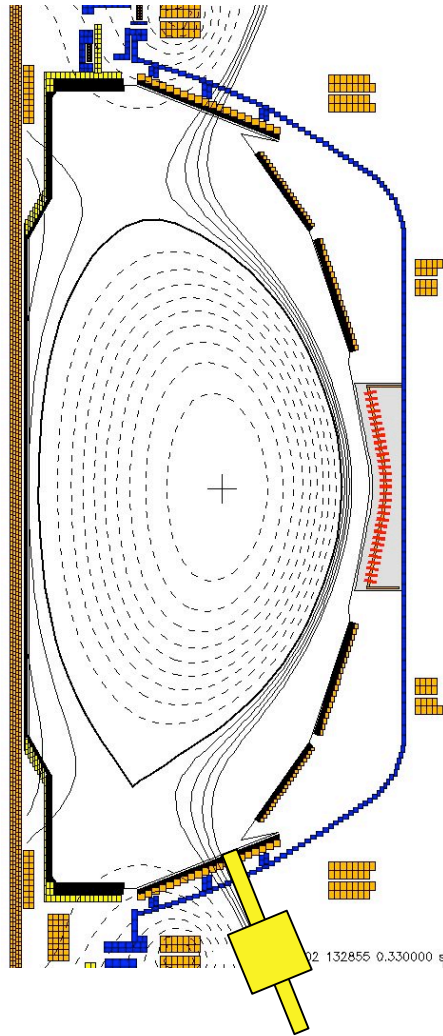

132855 during the flat top

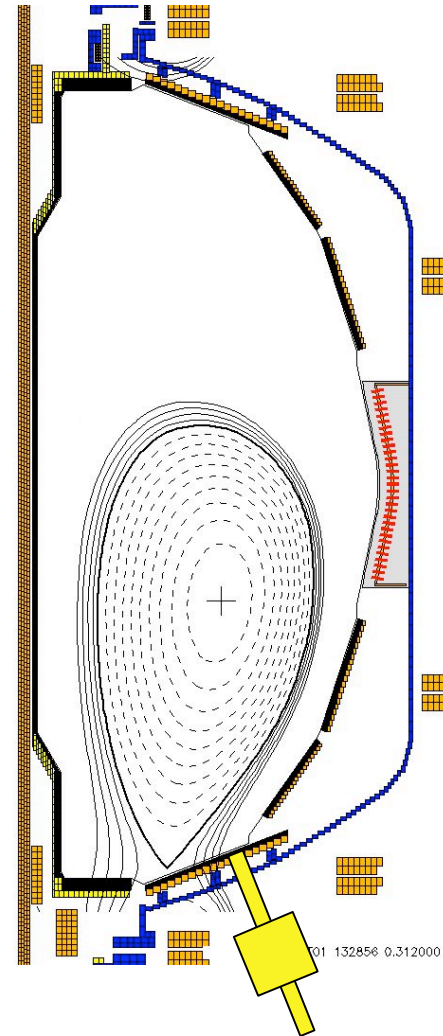

Repeat of 132856
At the end of the VDE

Model discharge 129848

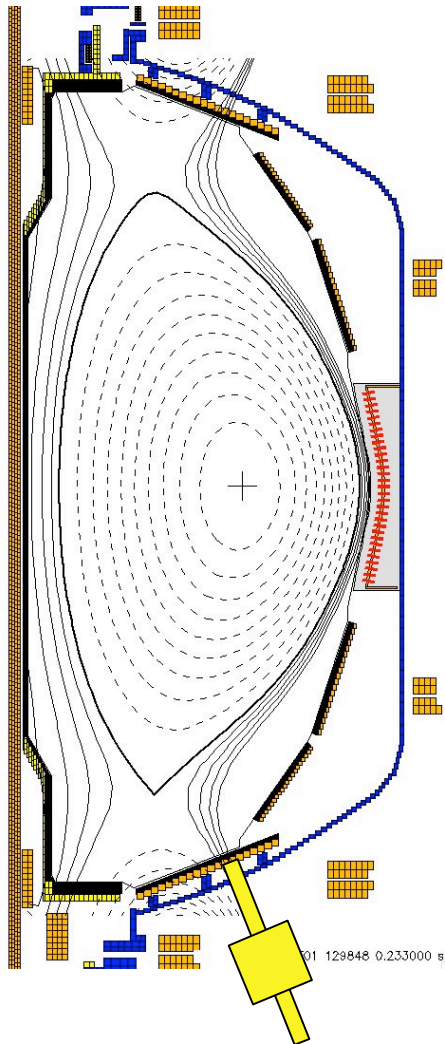

129848 during the flat top

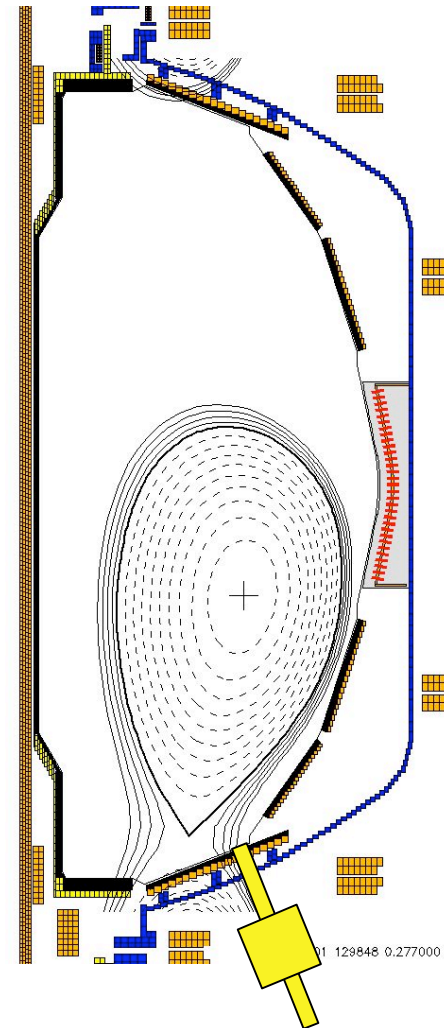

129848 Just before vessel contact

Diagnostics:

- A fast camera will view the probe to detect dust ejected.
- IR camera and thermocouples mounted on the probe head will be used to assess the temperature excursion
- A dry run will establish no dust is lost by probe motion. This would entail loading the probe with a pre-weighed quantity of dust, inserting it into the machine, withdrawing it and reweighing the dust.
- The probe head will be fabricated from boron nitride (an insulator) to avoid issues with induced JXB forces.
- Analysis: we will compare the dust mobilization to that expected from ITER off-normal events.
- A potential venue is the International Conference on Plasma Surface Interactions PSI19 next May in San Diego.