

ELECTROMAGNETIC AND STRUCTURAL ANALYSES OF THE ITER CENTRAL SOLENOID FEEDERS

A. M. Zolfaghari^a, K. Freudenberg^b

^aPrinceton Plasma Physics Laboratory, Princeton, NJ 08543-0451

^bUS ITER, Oak Ridge National Laboratory, Oak Ridge, TN 37930

Abstract—

In the current ITER design, the six central solenoid coils are fed with electrical currents through three upper feeders and three lower feeders. These feeders, that are mounted on the key blocks, are required to withstand cooling and electromagnetic loads through different ITER operation scenarios. The $I \times B$ interaction of the currents and the magnetic field exerts loads on the superconducting leads and busbars in the feeders. These loads are transferred to the feeder structures through clamps that hold the conductors along their paths.

The upper and lower ITER CS feeder structures including the feeder boxes, bus bars, and coil leads for CS2U and CS2L coils were analyzed using finite element techniques. The coupled Electromagnetic-structural FEM analyses included the effect of electromagnetic forces as well as liquid Helium cooling on the bus bars and coil leads for two different ITER scenarios. The results of these analyses and their implications for the design of feeders are discussed in this paper.

Keywords-ITER; Central Solenoid; Feeder; EM modeling

I. INTRODUCTION

There are two sets of CS coil feeders on ITER. The 3 upper feeders, arranged 120 degrees apart toroidally, bring the current and feed the upper CS coils: CS1U, CS2U and CS3U. The same way lower CS feeders feed the lower CS coils: CS1L, CS2L and CS3L. The feeders rest on a stand that is attached to the key blocks on the top and bottom of the CS stack. The feeders house twin box connections that connect the CS coil lead extensions and the busbars bringing the current in and out. In the analyses reported here we examine the upper feeder feeding CS2U and the Lower feeder feeding CS2L. The objective of these analyses is to predict the stresses in the feeders as result of the $I \times B$ interaction of the current in the conductors and the magnetic field of the entire machine.

Two ITER operation instances/scenarios are considered here namely End of Burn (EOB) and Initial magnetization (IM). Results of a global analysis of the CS and TF structures of ITER tokamak for different scenarios are used in this analysis. The displacements of key installation points of the feeder structure to the machine are mapped to the corresponding surfaces in lower and upper structures. The effect of the change in the temperature from room temperature to liquid Helium temperature is also taken into account.

II. FINITE ELEMENT MODELS & ANALYSES

The analysis model geometry for each upper and lower feeder analyses is divided into two separate geometries. For the upper (and similarly for the lower) feeder box analysis, one geometry model is used for electromagnetic modeling with the MAXWELL code [1]. This geometry included the TF, PF and CS magnets as well as the plasma. In the EM analysis the corresponding currents for these coils are modeled in order to establish the background field for each scenario. Figures 1 and 2 show this geometry. In this geometry, used to compute EM forces, only the current carrying components of the feeder structures namely the current leads and bus bars are needed.

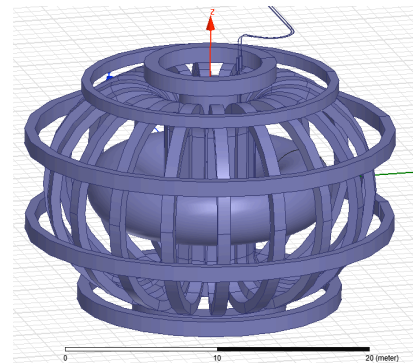

Figure 1. EM geometry with all currents

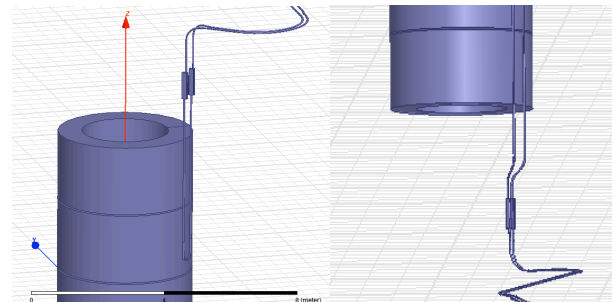

Figure 2. EM geometries of the upper and lower feeders with TF and PF coils and plasma hidden

The structural models used for stress analyses are shown in Figures 3 and 4 for upper and lower feeders.

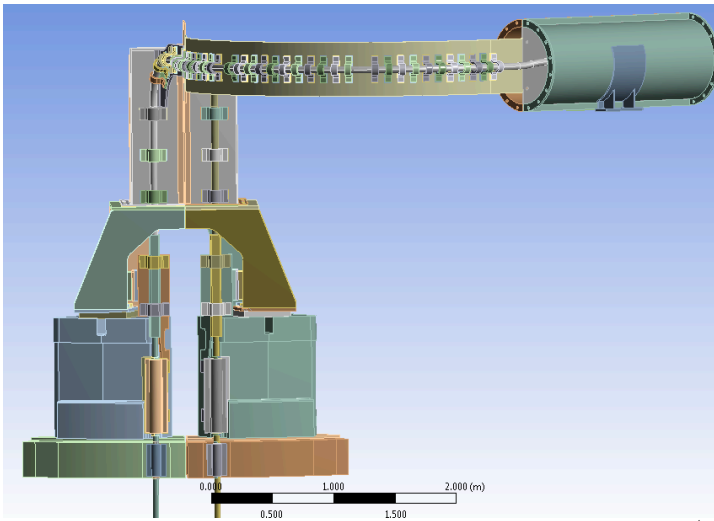

Figure 3. Upper feeder model (some parts removed to show details)

Property	Value	Unit
Density	7850	kg m ⁻³
Isotropic Secant Coefficient of Thermal Expansion		
Coefficient of Thermal Expansion	1.2E-05	K ⁻¹
Reference Temperature	293	K
Isotropic Elasticity		
Derive from	Young's...	
Young's Modulus	1.5E+11	Pa
Poisson's Ratio	0.3	
Bulk Modulus	1.25E+11	Pa
Shear Modulus	5.7692E+10	Pa

Table 1. Structural properties of the superconductor

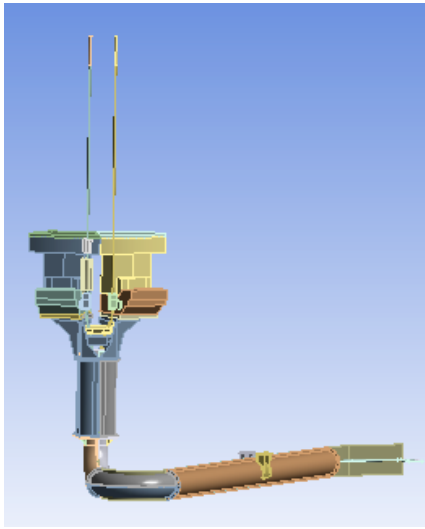

Figure 4. Structural model of the lower feeder

In all geometries the conductors (i.e. bus bars and coil leads) are modeled as smeared-property monolithic conductors. The material properties of the superconducting conductors are listed in Table 1. All other components are set to stainless steel 316 LN except for insulation parts in the busbar clamps which are set to G10. The contact conditions between the conductors and their clamps are set to “no separation” which allow slippage between parts. All other contacts are bonded.

A. Electromagnetic Analysis

The EM force (density) from the EM analysis is mapped directly on the current carrying components of the detailed structural analysis geometry. EM loads are analyzed for coils and plasma currents corresponding to EOB and IM scenarios. The EM force density loads are mapped from the MAXWELL finite element mesh to a dissimilar ANSYS [2] structural FE mesh of the conducting parts. The force density vector plots shown in figure 5 and 6 are results of the interaction of the current in the upper feeder conductors with the external magnetic fields, strongest among them being the CS field.

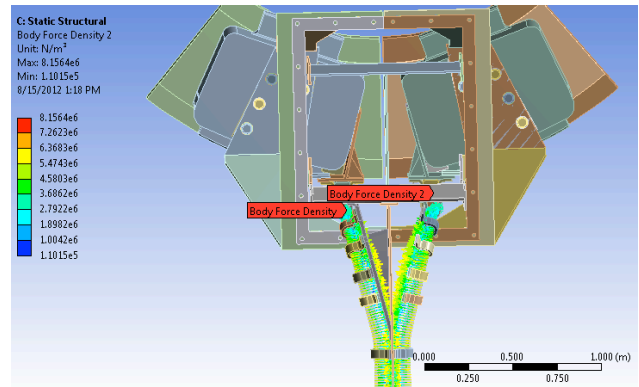

Figure 5. EM loads on conductors (from the top of feeder box)

III. ANALYSIS RESULTS

1) Upper Feeder Results

Figures 8 and 9 are plots of equivalent stress with EM, displacement, cooling and gravity loads for the EOB case. As can be seen the stresses in the feeder box components are low.

Figure 10 is a contour plot of displacement in the Z-direction showing a combination of shrinking conductors (due to liquid helium cooling) and the imposed displacements on the coil leads and the bus bars. This combined with the EM loads on the conductors result in higher stresses (above 300 MPa) in the conductor (where it makes the 90 degree turn), in the feeder, and in the clamps and backing plates that hold the bus bar conductor in place (figure 9).

Similar stress results can be seen in the IM load case scenario in figure 11.

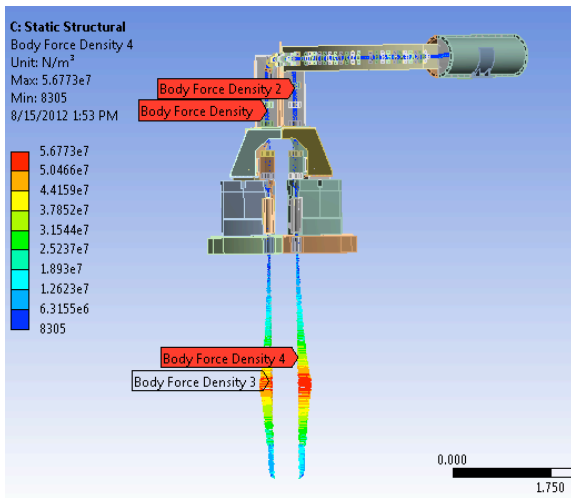

Figure 6. EM loads on conductors (EOB). The high loads shown as red spots on the leads are results of interaction of current with leaking CS field.

B. Multiphysics Analysis

Structural loads from the ITER tokamak, in the form of displacements, are imposed on the feeder models. These displacements are imposed on the surfaces where the feeders are attached to other ITER structure. The X, Y, and Z displacements for these locations are obtained from the ITER CS global ANSYS model (Figure 6). Displacement for load cases corresponding to EOB and IM scenarios are applied.

Cooling to 4 deg K is also implemented as a condition on all components of the upper and lower models for both EOB and IM cases. The gravity load was also taken into account.

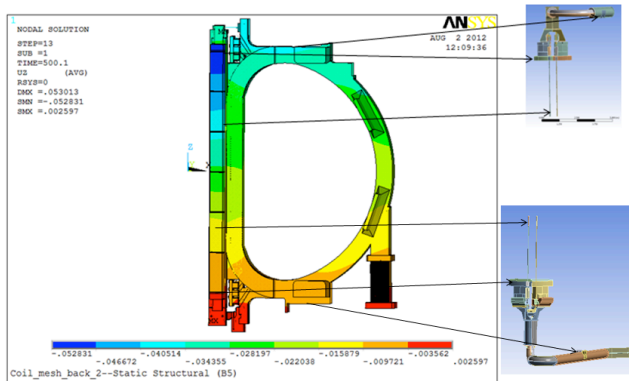

Figure 7

In the analyses reported here the length of the coil leads going from the feeder box to the CS2U/L coils are unsupported from the key block to the coils. In reality, the leads are supported by cassettes that run vertically and are attached to the outside of the CS coils. The analysis of these cassettes is the subject of another ongoing study.

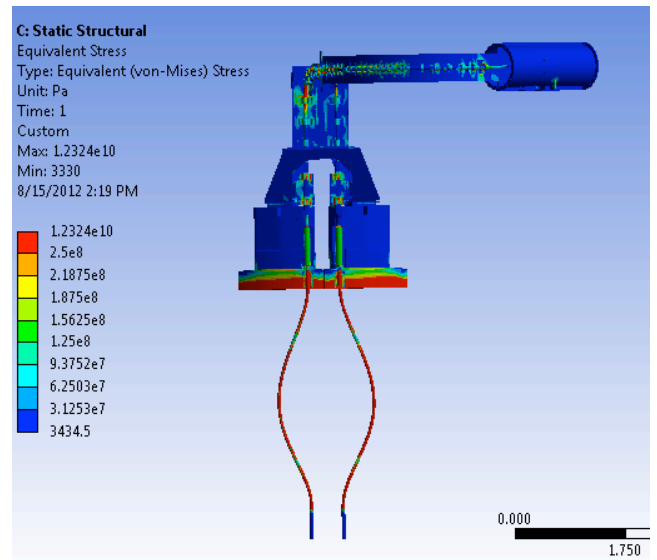

Figure 8. Stress in upper feeder parts (EOB)

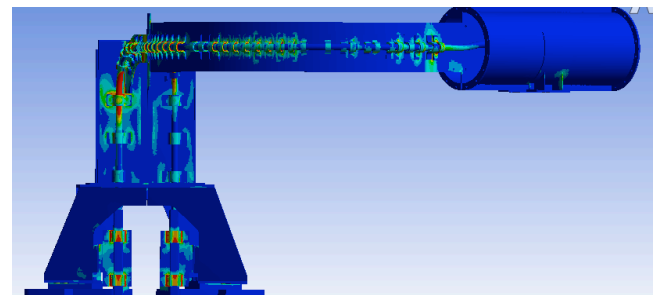

Figure 9. Stress in upper feeder parts

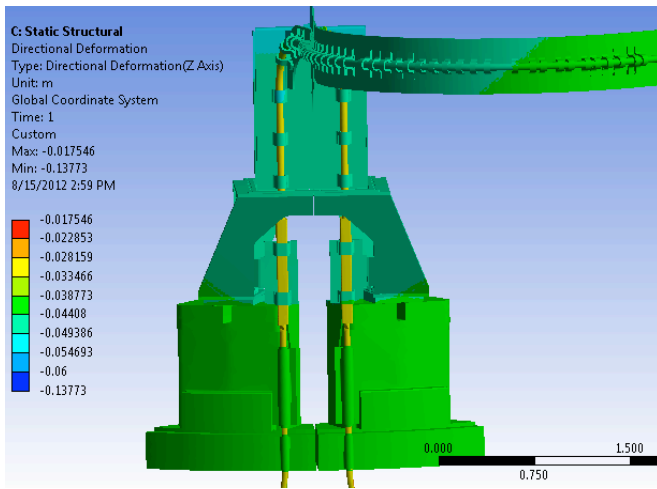

Figure 10. Vertical deformation in upper feeder parts

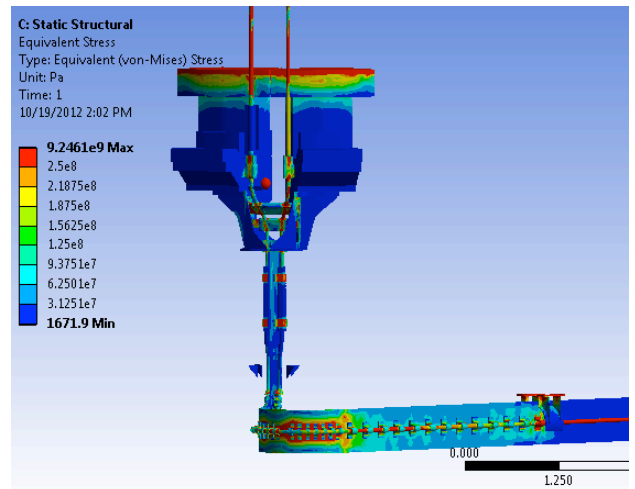

Figure 12. Stress in lower feeder parts (EOB)

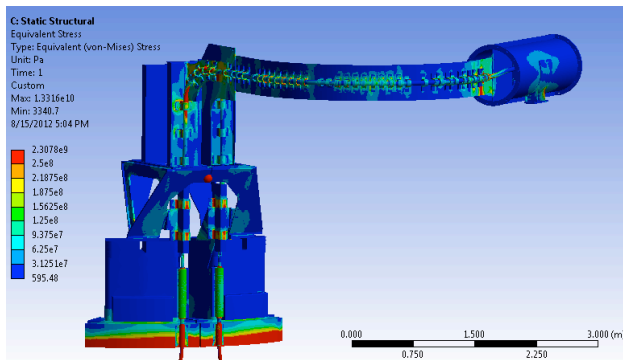

Figure 11. Stress in upper feeder parts (IM)

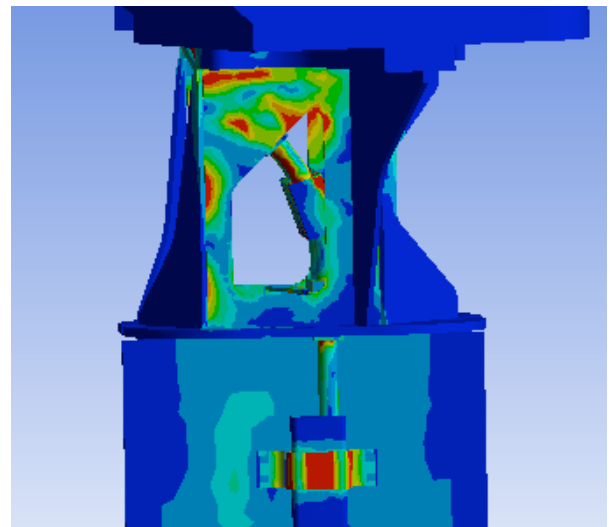

Figure 13. Stress in lower feeder stand (EOB)

2) Lower Feeder Results

Figures 12 and 13 are plots of equivalent stress with EM, displacement, cooling and gravity loads on the lower feeder parts for the EOB case. As can be seen the feeder box stand and clamps, that secure the coil leads and the bus bar to the lower feeder box components, see high stresses due to the combination of EM (EOB load case) and other loads. Similar results can be seen in the IM load case in figure 14.

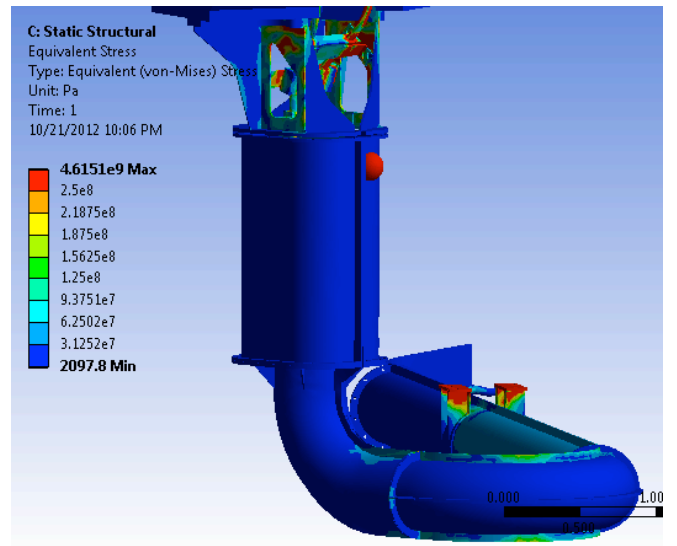

Figure 14. Stress in lower feeder parts (IM)

IV. CONCLUSIONS

For the upper feeder in both EOB and IM load cases, the stresses in the feeder box and stand are low. However, the stress in the conductors, clamps, and backing plates are high locally. Attention needs to be paid to the size and how the clamps constrain the movement of the conductors. Perhaps it would be necessary to provide a mechanism to let the clamps slide with respect to the backing plate especially around the 90 degree turn in the feeder box. Also as creep sets in for the CS coils, and retightening of the super bolts are required, there may be a need to loosen the clamps holding the conductors as to not create initial stress in the conductors.

The lower feeder box and stand are closer to the center of the machine (and the center of the CS coils) because of the inward turn in the coil leads prior to entering feeder box (see figure 2). This puts the lower feeder and stand where the magnetic field amplitude is higher. Higher field leads to higher forces. Stresses in the feeder box are substantially below the allowable for stainless steel. However the feeder box stand, and clamps that secure the coil leads and the bus bar to the lower feeder box components see high stresses that may exceed the allowable. More attention will be needed in the design of the clamps and lower feeder box stand to relieve these stresses.

ACKNOWLEDGEMENTS:

Work supported by U.S. DOE Contract No. DE-AC02-09-CH11466

DISCLAIMER:

The views and opinions expressed herein do not necessarily reflect those of the ITER Organization

REFERENCES

- [1] ANSYS Inc. www.ansoft.com/products/em/maxwell
- [2] Ansys Inc. <http://www.ansys.com>