

Power Supply Changes for NSTX Resistive Wall Mode Coils*

S. Ramakrishnan, C. Neumeyer, R. Mozulay, E. Baker, R. Hatcher, J. Lawson, W. Que, X. Zhao
Princeton Plasma Physics Laboratory¹, Princeton, NJ 08543-0451

Abstract

The National Spherical Torus Experiment (NSTX) has been designed and installed in the existing facilities at Princeton Plasma Physics Laboratory (PPPL). Most of the hardware, plant facilities, auxiliary sub-systems, and power systems originally used for the Tokamak Fusion Test Reactor (TFTR) have been used with suitable modifications to reflect NSTX needs. Prior to 2004, the NSTX power system was feeding twelve (12) circuits in the machine. In 2004 the Resistive Wall Mode (RWM) Coils were installed on the machine to correct error fields. There are six of these coils installed around the machine in the mid-plane. Since these coils need fast and accurate controls, a Switching Power Amplifier (SPA) with three sub-units was procured, installed and commissioned along with other power loop components. Two RWM Coils were connected in series and fed from one SPA sub-unit. After the initial RWM campaign, operational requirements evolved such that each of the RWM coils now requires separate power and control. Hence a second SPA with three sub-units has been procured and installed. The second unit is of improved design and has the controls and power components completely isolated. The existing thyristor rectifier is used as DC Link to both of the Switching Power Amplifiers. The controls for the RWM are integrated into the overall computer control of the DC Power systems for NSTX. This paper describes the design changes in the RWM Power system for NSTX.

INTRODUCTION

RWM coils were designed and installed in NSTX since suppression of the RWM by active feedback control was considered desirable for improving machine performance including error field correction. Six individual saddle coils, each about 60° wide toroidally, spanning the mid-plane of the vessel with a vertical height of 38" have been installed. The coils are located at a major radius of 69.3", within the toroidal field coils. Because of the large number of interferences in the desired coil path around the already crowded Torus, the actual shape and geometry of each coil section varied somewhat from the nominal dimensions. Effort was made to equalize the areas enclosed by the coils within 5%. Each coil section consists of two turns of 3/4" square insulated copper bar supported from the Outer Vessel.

The six coils were paired into three groups, each group comprising of two diametrically opposite coils. One Switching Power Supply (SPA) with three independently controlled sub-units was purchased, installed, and commissioned in March 2005, with one sub-unit feeding one pair of RWM coils. One of the existing 24kA DC supplies originally used for TFTR was used as the DC input to the SPA. This DC supply was over-rated for the application since the DC link had to only carry a maximum of 1600 Amps. Based on operational experience it was decided to have each coil independently

controlled. Hence a second SPA of improved design, with three sub-units was procured and put into operation in 2011. This paper describes the changes of the power feed to the RWM coils.

A. RWM POWER SYSTEM DESCRIPTION

Overall system specifications.

Figure 1 depicts the overall power system for the RWM Coils. With the changes there are two SPAs each with three subunits with each subunit feeding one coil. One of the thyristor power supplies originally used for TFTR is used as the DC source to feed the RWM coils via a Switching Power Amplifier (SPA). The DC supply is provided with its own Disconnect and Ground Switch. A series current limiting reactor and power resistor is also provided in the output DC circuit. Voltage monitors are provided for the DC supply at the Disconnect Switch. The output leads from the Disconnect Switch are connected to the input side of the double pole double throw disconnect switch (DPDT) of the SPA. This DPDT was provided to positively ground the SPA Capacitor banks during maintenance. Each SPA has three sub-units each rated for 3333 Amps. The SPA is designed such that all the three sub-units can be operated in parallel to feed a single load at 10,000 Amps if so required. The output from each sub-unit is connected to a double pole disconnect & ground switch (DGS). The output from each of the DGS is connected to one RWM coil, using a 4- conductor 500kcmil cable nearly 330 feet long. Two conductors are used for one coil and the other two for a second coil. The two leads of each coil are brought into a common terminal box, located in the NSTX Test Cell (NTC). Following is the system specifications as currently installed:

DC Supply (Six pulse bridge) - Input to each SPA:

DC Voltage: 0-1012.8 V DC (adjustable via phase control).
Peak of Rectified AC Voltage: $\sqrt{2} \times 750 = 1060V$ peak.
Maximum Continuous Output: 0.5kA.
Maximum Pulsed Output: 4.5kA-3.25 sec every 300 sec.
Short Circuit Current: 30.5kA peak limited to 15kA with series current limiting resistor.

SPA Output – Each of the three sub-units:

Peak Current: 3.33kA
Wave shape: DC to 100Hz sinusoidal AC.
Pulse Duration: 6 seconds.
Repetition Period: 300.0 seconds.
Switching Frequency: 7.5 kHz

*This work supported by the US DOE Contract No. DE-AC02-09CH11466

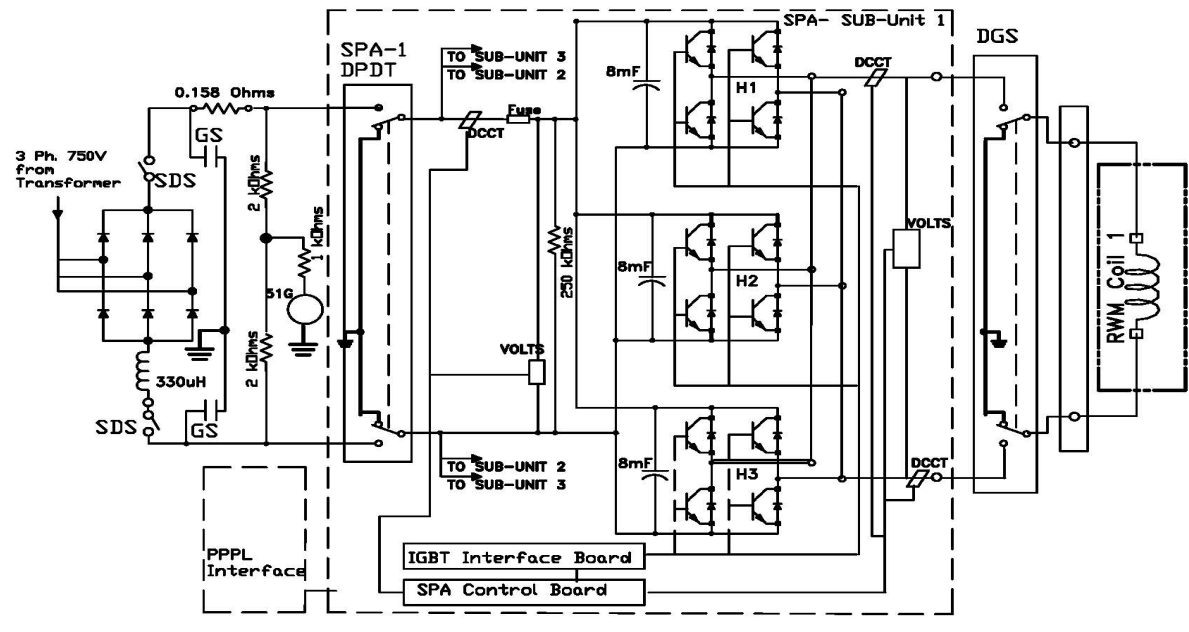

Figure 1 – RWM Power Loop

Load (One coil and associated Cabling):

Resistance: 19 milliohms; Inductance: 30 μ H.

Note: Each coil has two turns and is designed for a pulsed current of 5000 amps for 6 seconds every 600 seconds.

B DC Link (Thyristor Power Supply feeding SPA)

PPPL has a 5kA power supply with thyristor rectifier and bypass modules at D-Site which was originally used for TFTR. The power supply has two Sections A & B, each of which provides an equivalent rating of 1 kV, 4.5 kA – 3.25 seconds equivalent square wave (ESW) every 300 seconds, and is fed by one three winding transformer. The SPA-1 is fed from Section A and the newly purchased SPA-2 is fed from section B. In order to limit the short circuit current in this circuit, a series DC current limiting reactor of 330 μ H and a series current limiting resistor of 40 milliohms are provided in the input power loop. Like the SPA-1 DC link capacitor, the SPA-2 DC link Capacitor bank has also a value of 0.072 Farads. The charging circuit as designed is over-damped. The firing angle control ramps up the voltage during charging to limit the total charging current to be under 1500 Amps.

C Switching Power Amplifier (SPA)

SPA-1 was specified and purchased in 2004 to feed the three groups of RWM coils. The unit was provided by I.E. Power Ltd. Mississauga, Ontario Canada. The unit was commissioned and put into operation in 2005. When decision was made to provide individual feeds to each of the six RWM coils, a second Switching Power Amplifier (SPA-2) was purchased in 2010 and commissioned in 2011. Both SPA-1 & SPA-2 are of same rating, water cooled, each with three sub-

units rated at 3.33kA, each of which can be individually controlled or operated in parallel, to provide a 10kA load current. Each sub-unit is provided with three H-bridges operating in parallel. Each H-bridge has four IGBT devices, and forms one module. Figure 1 shows the essential parts of the SPA. These are

- Input double pole double throw (DPDT) disconnect Switch for disconnecting and grounding the SPA from DC link
- Input fuses to each of the three SPA sub-units.
- Three H-Bridges in parallel for each sub-unit. Each H-bridge module comprises of:
 - Four - 2400A, 1700V IGBTs switching at 3.75kHz
 - Two - 4000uF caps for filtering and to provide energy storage for supplying reactive power for pulsed load
 - One shunt resistor
- Current sharing inductors in each leg (10uH), in the output of each H-bridge (not shown).
- Pulse Width Modulator (PWM) control components
- Voltage and current monitors
- Other miscellaneous control and protection components including dump resistors, etc.

The PWM control of the IGBTs in the H-bridge is a simple means to provide bipolar output at different amplitudes and frequencies by changing the duty cycle (time on/total time) of the devices. The DC source provides all the power required and the DC link capacitor bank stores and delivers the energy at the desired current level.

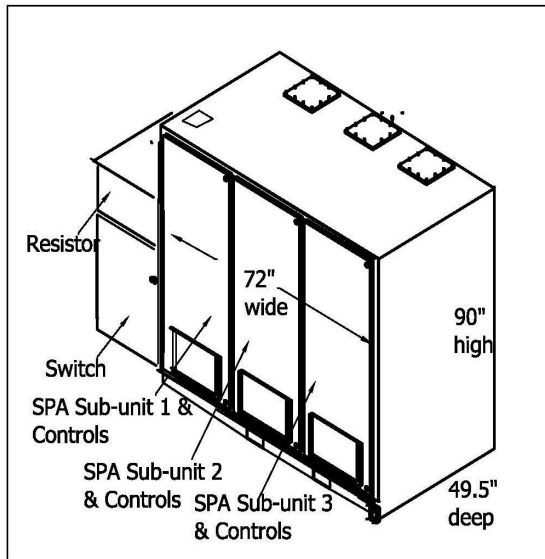

Figure -2: Outline of SPA-1

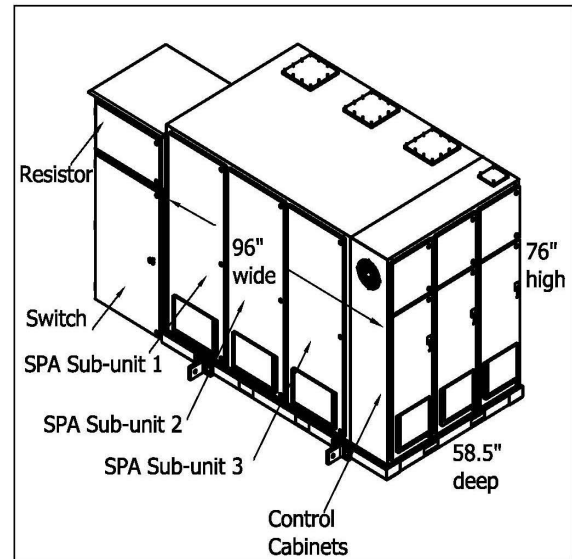

Figure -3: Outline of SPA-2

D Design changes in SPA-2

In order to meet the operational requirements and PPPL safety standards specific design features were stipulated for the second SPA. The key features are the following:

- The Power & Control items are housed in separate enclosures without any co-mingling of control and power components, and are completely isolated. See figures 2, 3, 5 & 6.
- The IGBT controls were isolated fiber-optically. The 120V AC required to be provided to the control card for the H-Bridge was provided with isolation transformers.
- The control components inside the Power cabinet such as CT terminals and leads, etc. are housed in grounded metallic enclosures, and provided with grounded metallic conduits for the cables, to take the signals to the control cabinets.
- Other control components inside Power cabinet which could not be conveniently provided with metallic enclosures were optically isolated and fiber cabling was installed. These signals are sensing of fuses, flow switches, resistor temperature, cabinet temperature, and door switches.
- Fusing for each of the three H-Bridges in each subunit was provided.
- Twisted shielded pairs are used for all control cabling to minimize interference problems.

Interlocks: The SPA is not given a permissive unless the DC Link system is ready to charge the SPA. This also insures that

the cooling water system is functional. When the permissive is given, the dump resistors across the capacitor bank are removed. When the capacitor bank is charged, the SPA sends a "Ready" signal, indicating that it is ready to pulse.

A modified Kirk key system was designed and installed to safely access the equipment.

E Monitoring and Controls (Refer to Figure 4)

Monitoring

A Real Time Control System monitors the input and output voltages and currents of each sub-unit. The same signals along with the faults are monitored via the EPICS system. Pulse width modulation is used for switching the H-Bridge. A train of pulses are produced that vary in width giving a resultant averaged signal as set by the controls.

Controls:

Closed loop current control, voltage control, and open loop control are provided for the SPA. Operation can be in one of the three modes. In the Current Mode, the incoming analog signal represents the desired current and an internal PID feedback system adjusts the pulse width of the IGBTs to provide the desired current. In the Voltage Mode, the incoming signal represents the desired output voltage and the internal feedback system again controls the pulse width to provide the desired output voltage. In the Open Circuit Mode, the analog input represents the desired duty cycle. No internal feedback is used. During Plasma operations the SPAs use Open circuit mode and the feedback is provided by the NSTX Real Time Data Acquisition System.

Each sub unit operates independently using a set point supplied by an external control system. The set point is simple analog signal, +/-10V which corresponds to a current of +/-4kA. The set point gets delivered as a digital word, over a fiber optic communications link, from the real time control computer which is then converted to the analog reference at the SPA sub unit input by an Optical to electrical conversion board. In addition to the digital reference control bits are included in the digital word that enable the sub unit for a given pulse period. A block diagram of controls is given in Figure 4 below.

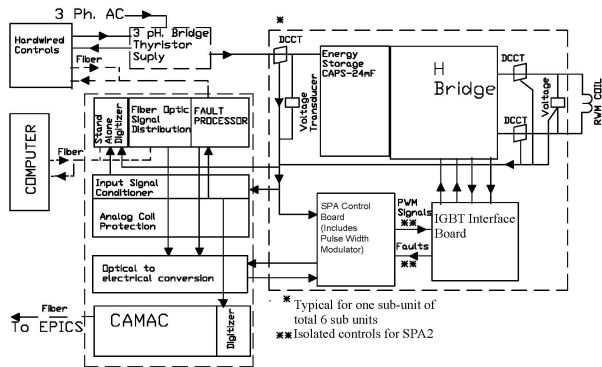

Figure 4
Block Diagram of controls

A PLC was purchased and installed for operation of all the RWM Safety Disconnect switches. Siemens PLC - Simatic S7-300 system was purchased and installed. The PLC enables operation and monitoring of the disconnect switches.



Figure 5
View of SPA-1

F. Circuit Power Cabling

Originally when only one SPA was available the six RWM coils were paired into three groups and each group of two coils was fed from one sub-unit of the SPA. Anticipating a future purchase of an additional SPA we had installed a four conductor cable for each group with two conductors in

parallel for each pole. After the installation of the second SPA one of these conductors in each pole was released and used to feed a dedicated coil.

G. Protection

Internal Protection:

The SPA2 is also purchased as a self-protecting unit. The SPA2 internal interlocks and protection includes door switches, flow switches, overcurrent features etc., similar to the SPA1.

The H-bridges are provided with “Semikron Integrated Intelligent Power” (SKIIP) modules which are self-protecting. Also the unit is internally tripped if a fault is detected.

If a fault is generated in the SPA, the IGBTs are switched off and the capacitor bank is discharged.



Figure 6
View of the front of SPA-2

Circuit Protection:

The DC link power supply is 3- phase thyristor controlled unit and is rated at 1kV – 4.5kA pulsed. The supply is self-protected with a built-in fault detector which trips the power supply in case of a fault (e.g., overcurrent, pulse overtime and others). Basically the faults are grouped into three categories: 1) alarm only, 2) suppress rectifier and fire bypass, 3) AC breaker of the power supply is tripped. Thus, electronic measures (suppression and bypass) are undertaken before activation of a breaker trip thereby reducing the wear and tear on the mechanical breaker.

In addition to the internal protection on overloads within the SPA, an external protection scheme has been implemented to protect the RWM coils. An Analog Coil Protection (ACP) unit was designed and installed for each of the six

RWM Coils. Redundant ACP channels are provided. The ACP will trip the SPA and the DC Link input supply:

1. If Coil over-current occurs
 2. If there is presence of current at a level of a coil current of 0 to 10% (adjustable) of the full scale transducer value (i.e., 0 to 4000 Amps) for more than an adjustable duration of time in increments of 0.1 second (0.1 to 99.9 seconds).
 3. If more than one pulse is imposed before an adjustable waiting period of 1 to 999 seconds in one-second increments.
 4. If the $\int i^2 dt$ is more than the permissible value.
 5. If the two redundant DCCTs on each RWM pole, differ by more than 0 to 10% (adjustable) of full scale.
- The ACP simulates coil cooling using a single exponential decay adjustable from 50 seconds to 5000 seconds.

Ground Fault Protection:

NSTX circuits are all grounded through high resistances. Thus a single ground fault does not result in any damage. All the RWM circuits are provided with a ground detection and trip scheme.

H Analysis and Simulation:

Circuit parameters were all calculated and then measured or obtained from manufacturer's data. The total power to be delivered to the RWM circuit was calculated to be 683 kW. Thus the DC source will be delivering about 725amps to each SPA, during pulsing at the rated load. Input charging circuit fuse rating was analyzed and was provided with a value of 350A per sub-unit for SPA-1. However for SPA-2 each of the three H-Bridges in each of the three sub-units have been individually fused (160A) instead of the common sub-unit fuse. The fuse calculations are based on a) fuse must not blow if full charging voltage is applied to all modules simultaneously and b) fuse must blow if there is a shorted capacitor in any of the H-bridges.

The RWM circuit was also simulated in PPPL using the PSCAD program. All the circuit components are modeled and incorporated in the simulation circuit. Performance was close to simulation.

I Conclusions:

Based on operational requirement a second SPA-2 was purchased and installed thereby providing dedicated feed for each of the six RWM Coils. The SPA-2 was designed with desired improvements. Safety is given the top priority at PPPL. Hence the unit was specified to meet the PPPL safety and interface requirements. It may be noted that SPA-1 interfaces had to be modified at site to meet PPPL safety standards, and all the external interconnections were made via fiber-optic cables to insure safety.

Double pole double throw disconnect and grounding switches were purchased and installed in each of the RWM coil circuit to safely isolate and ground the equipment. The Kirk-key system was modified and installed to insure safe accessing of equipment.

Inductance and resistance of the power loops were calculated. These were then measured and found to be in close agreement. SPA performance was simulated using the PSCAD program with measured circuit parameters. The simulation closely matches the actual performance.

REFERENCES

- [1] C. Neumeyer, "SPA simulation using PSCAD" PPPL document
- [2] S. Ramakrishnan, et.al., "POWER SUPPLY FOR NSTX RESISTIVE WALL MODE COILS ", 21st IEEE/NPSS Symposium on Fusion Engineering, Knoxville, TN, September 2005.
- [4] S. Dewan, et al., "1400A, +/-900V Peak Pulse Switch Mode Power Supplies for SNS Injection Kickers", Proceedings of the 2003 Particle Accelerator Conference.
- [5] S. Dewan, ET. al., "1.12MVA Peak Two Quadrant Pulse Switch Mode Power Supply for SNS Injection Bump Magnet", Proceedings of EPAC 2002, France.

ACKNOWLEDGEMENTS:

We want to record our appreciation to Late Dr. S. Dewan and J. Zeng of I.E. Power, for their input for analyzing the SPA performance.
